

**REED SWITCH  
DATA BOOK  
1998**

**REED SWITCH**

**INTRODUCTION**

**1**

**APPLICATION NOTES**

**2**

**DATA SHEETS**

**3**

---

## NOTICE

1. The information contained herein can change without notice due to product or technical improvements. Before using the product, please make sure that the information being referred to is up-to-date.
2. The outline of action and examples for application circuits described herein have been chosen as an explanation for the standard action and performance of the product. When planning to use the product, please ensure that the external conditions are reflected in the actual circuit, and assembly designs.
3. When designing your product, please use our product within the specified operating ranges for operating voltage, power dissipation, and operating temperature. We will not be held responsible for use and operation of a product other than what is stated below.

Our company assumes no responsibility or liability whatsoever for any failure or unusual or unexpected operation resulting from misuse, neglect, improper installation, repair, alteration, accident, improper handling, unusual or physical electrical stress including, but not limited to exposure of parameters beyond the specified maximum ratings or operation outside the specified operating range.

4. Neither indemnity against nor license of a third party's industrial and intellectual property right, etc. is granted by us in connection with the use of the product or the information and drawings contained herein. We have no responsibility for any infringement of a third party's right which may result from the use of a product thereof.

The products listed in this document are intended for use in general electronics equipment for commercial applications (e.g., office automation, communication equipment, measurement equipment, consumer electronics, etc.). These products are not authorized for use in any system or application that requires special or enhanced quality and reliability characteristics nor in any system or application where the failure of such system or application may result in the loss or damage of property, death or injury to humans.

Such applications include, :traffic control, automotive, security, aerospace, nuclear power control, and medical equipment and life support systems.

5. No part of the contents contained herein may be reprinted or reproduced without our permission.

---

# CONTENTS

## REED SWITCH

1. INTRODUCTION .....	3
REED SWITCH PRODUCT OVERVIEW .....	4
REED SWITCH TYPICAL CHARACTERISTICS .....	5
GENERAL DESCRIPTION .....	11
1. Reed switch characteristics .....	11
2. Applications .....	11
3. Structure and operating principles .....	12
4. Permanent magnet drive .....	13
REED SWITCH RELIABILITY .....	16
PRECAUTIONS AND APPLICATIONS .....	24
DESCRIPTION OF SYMBOLS AND TERMS .....	28
2. APPLICATION NOTES .....	33
3. DATA SHEETS .....	39
ORD211 .....	40
ORD213 .....	48
ORD219 .....	56
ORD221 .....	64
ORD228VL .....	72
ORD2211 .....	80
ORD2212 .....	88
ORD229 .....	96
ORD2210 .....	104
ORD2210V .....	112
ORD234 .....	120
ORT551 .....	128
ORT233 .....	136

# REED SWITCH

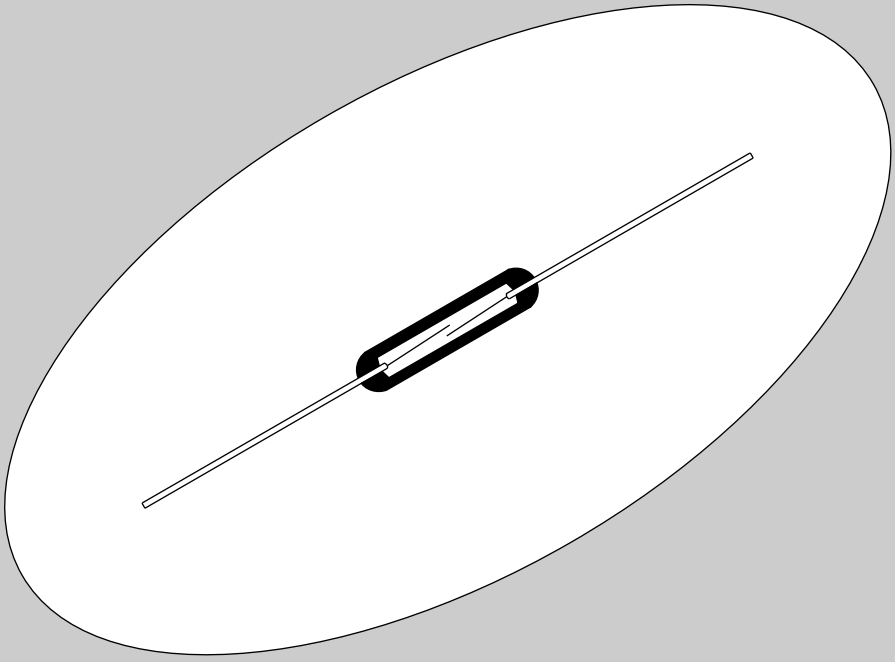



REED SWITCH PRODUCT OVERVIEW



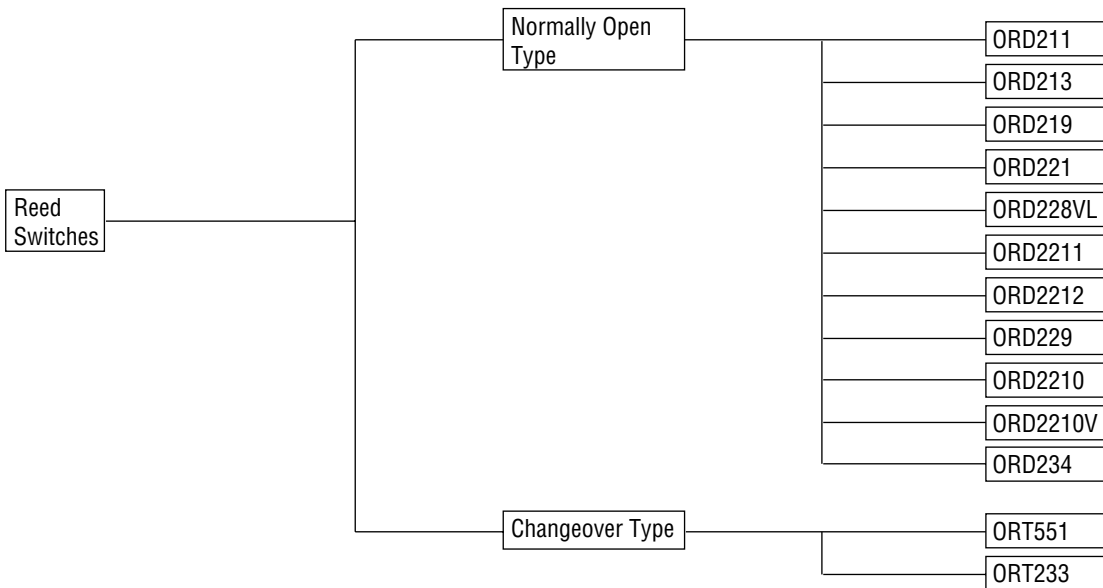

1





REED SWITCH TYPICAL CHARACTERISTICS

Part No.		ORD211	ORD213	ORD219	ORD221	ORD228VL
Electrical Characteristics	Contact type	1A	1A	1A	1A (OFF SET)	1A
	Pull-in value (PI) [AT]	10 to 40	10 to 40	10 to 30	10 to 30	10 to 45
	Drop-out value (DO) [AT]	5 min	5 min	5 min	5 min	5 min
	Contact resistance [mΩ]	100 max	200 max	100 max	100 max	100 max
	Breakdown voltage [DCV]	150 min	150 min (PI≥20)	200 min	200 min (PI≥20)	200 min (PI≥20)
	Insulation resistance [Ω]	10 <sup>9</sup> min	10 <sup>9</sup> min	10 <sup>9</sup> min	10 <sup>9</sup> min	10 <sup>9</sup> min
	Electrostatic capacitance [pF]	0.2 max	0.4 max	0.3 max	0.3 max	0.3 max
	Contact rating [VA,W]	1.0	1.0	10	10	10
	Maximum switching voltage [V]	DC 24/AC 24	DC 24/AC 24	DC 100/AC 100	DC 100/AC 100	DC 100/AC 100
	Maximum switching current [A]	DC 0.1	DC 0.1	DC 0.5	DC 0.3	DC 0.5
	Maximum carry current [A]	0.3	0.3	1.0	1.0	1.0
Operating Characteristics	Operate time [ms]	0.3 max	0.3 max	0.4 max	0.4 max	0.4 max
	Bounce time [ms]	0.3 max	0.3 max	0.3 max	0.5 max	0.3 max
	Release time [ms]	0.05 max	0.05 max	0.05 max	0.05 max	0.05 max
	Resonant frequency [Hz]	7500±500	11000±2000	5900±400	2750±250	5000±400
	Maximum operating frequency [Hz]	500	500	500	500	500
Standard Coil	Coil resistance [Ω]	600	600	450	450	450
	Number of Turns [T]	5000	5000	5000	5000	5000
	Dimensions [mm]	φ3.3×10	φ3.3×10	φ3.7×15	φ3.7×15	φ3.7×15
	Part No.	8	8	6	6	6
Operating Temperature Range		-40°C to 125°C	-40°C to 125°C	-40°C to 125°C	-40°C to 125°C	-40°C to 125°C
Features (contact material)		Ultraminiature (Rh: rhodium)	Extreme Ultraminiature (Rh)	General Purpose Miniature (Rh)	Miniature Offset (Rh)	General Purpose Miniature (Rh)
Page		40	48	56	64	72



Part No.		ORD2211 	ORD2212 	ORD229 	ORD2210 	ORD2210V 
Electrical Character- istics	Contact type	1A	1A	1A	1A	1A
	Pull-in value (PI) [AT]	20 to 60	15 to 35	20 to 50	15 to 60	20 to 60
	Drop-out value (DO) [AT]	8 min	DO/PI>0.8 (PI≥20)	6 min	7 min	7 min
	Contact resistance [mΩ]	100 max	100 max	100 max	100 max	100 max
	Breakdown voltage [DCV]	200 min (PI≥20)	150 min	600 min(PI≥35)	250 min (PI≥20)	1000 min
	Insulation resistance [Ω]	10 <sup>9</sup> min	10 <sup>9</sup> min	10 <sup>10</sup> min	10 <sup>10</sup> min	10 <sup>10</sup> min
	Electrostatic capacitance [pF]	0.3 max	0.5 max	0.5 max	0.5 max	0.5 max
	Contact rating [VA,W]	50 (12 V-3.4 W Lamp)	10	DC 50 W/AC 70 VA	DC 50 W/AC 70 VA	100
	Maximum switching voltage [V]	DC 100/AC 100	DC 100/AC 100	DC 350/AC 300	DC 200/AC 150	DC 350/AC 300
	Maximum switching current [A]	DC 0.5 Inrush 3 A	DC 0.2	DC 0.7/AC 0.5	DC 1.0/AC 0.7	DC 1.0
Maximum carry current [A]	2.5	0.5	2.5	2.5	2.5	
Operating Character- istics	Operate time [ms]	0.6 max	0.4 max	0.6 max	0.6 max	0.6 max
	Bounce time [ms]	0.4 max	1.0 max	0.5 max	0.5 max	0.5 max
	Release time [ms]	0.05 max	0.05 max	0.05 max	0.05 max	0.05 max
	Resonant frequency [Hz]	4600±500	3900±500	2500±250	2500±250	2500±250
	Maximum operating frequency [Hz]	500	500	500	500	500
Standard Coil	Coil resistance [Ω]	450	450	500	500	500
	Number of Turns [T]	5000	5000	5000	5000	5000
	Dimensions [mm]	φ3.7×15	φ3.7×15	φ4.6×21	φ4.6×21	φ4.6×21
	Part No.	6	6	3	3	3
Operating Temperature Range		-40°C to 125°C	-40°C to 125°C	-40°C to 125°C	-40°C to 125°C	-40°C to 125°C
Features (contact material)		Lamp load (Rh)	Closed Differential Low Operating Noise (Rh)	High Breakdown Voltage (Rh) High Power	High Power (Rh)	Vacuum Ultra High Breakdown (Rh) High Power
Page		80	88	96	104	112



Part No.		ORD234 	ORT551 	ORT233 
Electrical Character- istics	Contact type	1A	1C	1C
	Pull-in value (PI) [AT]	15 to 50	10 to 25	15 to 30
	Drop-out value (DO) [AT]	6 min	4 min	5 min
	Contact resistance [mΩ]	100 max	100 max	100 max
	Breakdown voltage [DCV]	250 min (PI≥20)	200 min (PI≥20)	150 min
	Insulation resistance [Ω]	10 <sup>10</sup> min	10 <sup>9</sup> min	10 <sup>9</sup> min
	Electrostatic capacitance [pF]	0.5 max	1.5 max	1.5 max
	Contact rating [VA,W]	10	3	3
	Maximum switching voltage [V]	DC 200/AC 100	DC 30/AC 30	DC 30/AC 30
	Maximum switching current [A]	DC 0.5	DC 0.2	DC 0.2
Maximum carry current [A]	2.0	0.5	0.5	
Operating Character- istics	Operate time [ms]	0.5 max	1.0 max	1.0 max
	Bounce time [ms]	0.5 max	N.O 1.0 max,N.C 1.5 max	N.O 1.0 max,N.C 1.5 max
	Release time [ms]	0.05 max	0.5 max	0.5 max
	Resonant frequency [Hz]	2200±300	6000±4000	6000±4000
	Maximum operating frequency [Hz]	500	200	200
Standard Coil	Coil resistance [Ω]	500	550	500
	Number of Turns [T]	5000	5000	5000
	Dimensions [mm]	φ4.6×21	φ4.6×10	φ4.6×21
	Part No.	3	10	3
Operating Temperature Range		-40°C to 125°C	-40°C to 125°C	-40°C to 125°C
Features (contact material)		Long Life (Rh)	Ultraminiature Changeover (Rh)	Miniature Changeover (Rh)
Page		120	128	136

Unit:mm

1

<p><b>ORD211</b></p>	
<p><b>ORD213</b></p>	
<p><b>ORD219</b></p>	
<p><b>ORD221</b></p>	
<p><b>ORD228VL</b></p>	
<p><b>ORD2211</b></p>	

Unit:mm

<b>ORD2212</b>	<p>Technical drawing of reed switch ORD2212. Dimensions: <math>0.35 \times 0.6</math>, <math>16.5 \text{ max}</math>, <math>43.9 \pm 0.3</math>, and <math>\text{Ø } 2.8 \text{ max}</math>.</p>
<b>ORD229, ORD2210, ORD2210V</b>	<p>Technical drawing of reed switch ORD229, ORD2210, ORD2210V. Dimensions: <math>\text{Ø } 0.6</math>, <math>21.0 \text{ max}</math>, <math>55.4 \pm 0.3</math>, and <math>\text{Ø } 2.75 \text{ max}</math>.</p>
<b>ORD234</b>	<p>Technical drawing of reed switch ORD234. Dimensions: <math>0.4 \times 0.65</math>, <math>21.0 \text{ max}</math>, <math>43.4 \pm 0.3</math>, and <math>\text{Ø } 3.5 \text{ max}</math>.</p>
<b>ORT551</b>	<p>Technical drawing of reed switch ORT551. Dimensions: <math>3-\text{Ø } 0.5</math>, <math>14.0 \text{ max}</math>, <math>51.6 \pm 0.3</math>, <math>56.1 \pm 0.3</math>, and <math>\text{Ø } 2.5 \text{ max}</math>. Labels NC and NO are present.</p>
<b>ORT233</b>	<p>Technical drawing of reed switch ORT233. Dimensions: <math>\text{Ø } 0.5</math>, <math>\text{Ø } 0.55</math>, <math>16.0 \text{ max}</math>, <math>51.6 \pm 0.3</math>, <math>56.1 \pm 0.3</math>, <math>\text{Ø } 3.3 \text{ max}</math>, and <math>\text{Ø } 0.55</math>. Labels NC and NO are present.</p>

1

**Environmental Characteristics**

Environmental conditions are the same for all models of reed switches.

	<b>Characteristics</b>	<b>Test Methods</b>	<b>Remarks</b>
Shock Resistance	No malfunction or change in characteristics when subjected to shock of 30 G (11 msec).	MIL-STD-202E METHOD 213B condition J	1
Vibration Resistance	No malfunction or change in characteristics when subjected to vibration of less than 20 G (10 to 1000 Hz).	MIL-STD-202E METHOD 204D condition D	2
Operating Temperature	-40°C to 125°C	—	3
Lead Tensile Strength	Withstand static load of 2.27 kgf in tension.	MIL-STD-202F METHOD 211A	—

- Remarks
1. When subjected to shock above 30 G, reed switch pull-in value may change.
  2. Because of reed resonance, frequencies over 1 kHz should be avoided. (Frequency range must be 10 to 1000 Hz.)
  3. Actually, reed switches can be operated beyond this temperature range if certain evaluation is done. It is noted that some magnet decreases magnetization at low temperatures.

The UL recognition number for our reed switches is E70063.

The CSA recognition number for our reed switches is LR86615.

1

## GENERAL DESCRIPTION

The reed switch was invented by Dr. W. B. Ellwood at Bell Telephone Laboratories in 1936. The first application was made during 1938 when the reed switch was used as a selector switch in a coaxial carrier equipment. Later, improvements of the reed switches were made in parallel with the development of the telecommunications technology. At the same time, the advantages of reed switches such as the speedy response time, hermetically sealed contacts, compact size and long mechanical life have contributed greatly to the development of telecommunications technology.

From 1956, when research and development on reed switches began in Japan, innovations have been made in improving contact performance, reducing overall size, improving manufacturing methods and reducing manufacturing cost. In addition to applications in switching systems, broad applications have been developed as sensors and controllers in automobile electrical devices, reed relays, and other instruments of various types.

Our reed switches of extremely superior quality are manufactured based on our own original technology for deactivating contact surfaces, high performance automatic sealing equipment and contact resistance measurement technology which uses magnetic flux scanning tests (FS method).

In particular, our process for deactivating contact surfaces takes the fatal problem of the conventional rhodium contact reed switch and suppresses increases in contact resistance due

to organic contamination. Thus, it became possible to manufacture reed switches with stabilized contact resistance. This original technology was awarded the highest award (Schneider Award) at the 21st Annual National Relay Conference.

Furthermore, we received the Schneider Awards at the 36th and 38th Annual National Relay Conferences for research into reed switch contact phenomena. Our engineering and technology capabilities are evaluated highly.

### 1. Reed Switch Characteristics

Reed switch characteristics are discussed below.

- (1) Reed switches are hermetically sealed within a glass tube with inert gas and do not receive any influence from the external atmospheric environment.
- (2) Quick response because of small mass of moving parts
- (3) The structure comprises the operating parts and electrical circuits arranged coaxially. Reed switches are suited to applications in radio frequency operation.
- (4) Reed switches are compact and light weight.
- (5) Superior corrosion resistance and wear resistance of the contacts assures stable switching operation and long life.
- (6) With a permanent magnet installed, reed switches economically and easily become proximity switches.

### 2. Applications

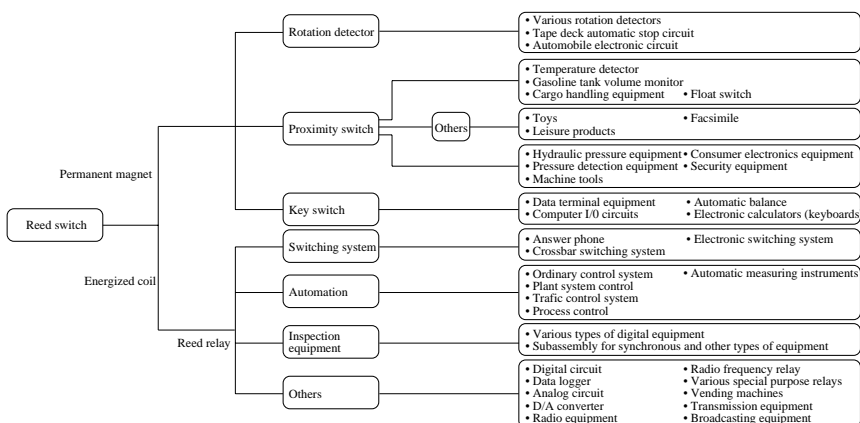

**3. Structure and Operating Principles**

As shown in Figure 3.1, the reed switches comprise two ferromagnetic reeds placed with a gap in between and hermetically sealed in a glass tube. The glass tube is filled with inert gas to prevent the activation of the contacts. The surfaces of the reed contacts are plated with rhodium.

As shown in Figure 3.2, the reed switch is operated by the magnetic field of an energized coil or a permanent magnet which induces north (N) and south (S) poles on the reeds. The reed contacts are closed by this magnetic attractive force. When the magnetic field is removed, the reed elasticity causes the contacts to open the circuit.

1

**Basic reed switch structure**

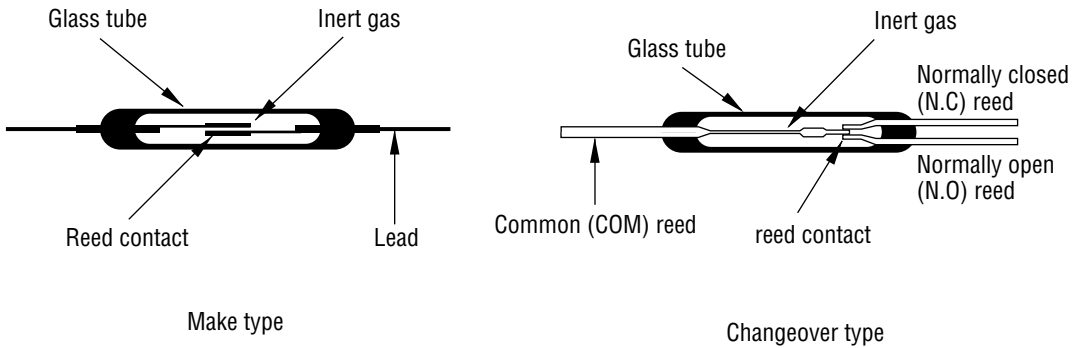

Figure 3.1

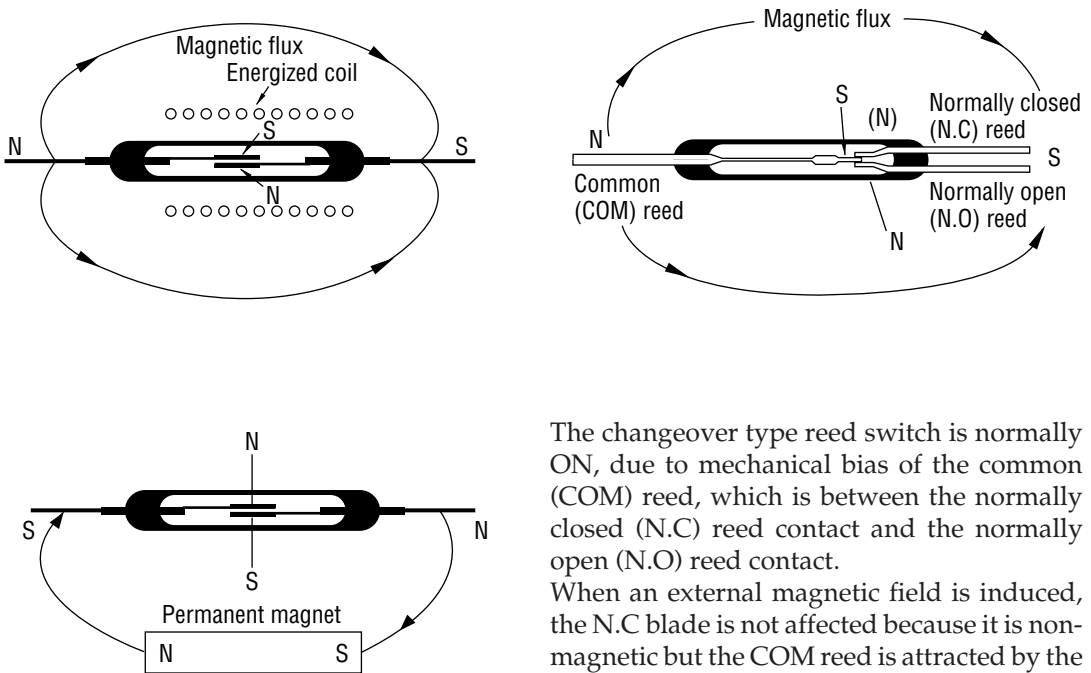

Figure 3.2

The changeover type reed switch is normally ON, due to mechanical bias of the common (COM) reed, which is between the normally closed (N.C) reed contact and the normally open (N.O) reed contact. When an external magnetic field is induced, the N.C blade is not affected because it is non-magnetic but the COM reed is attracted by the N.O reed and moves. When the magnetic field is removed, COM reed again moves to the N.C reed by mechanical bias.

**4. Permanent Magnet Drive**

When a reed switch is driven by a permanent magnet, the selection of the permanent magnet and the determination of its distance relative to the reed switch are done according to the following steps.

When a reed switch is driven by a permanent magnet, the selection of the permanent magnet and the determination of its distance relative to the reed switch are done according to the following steps.

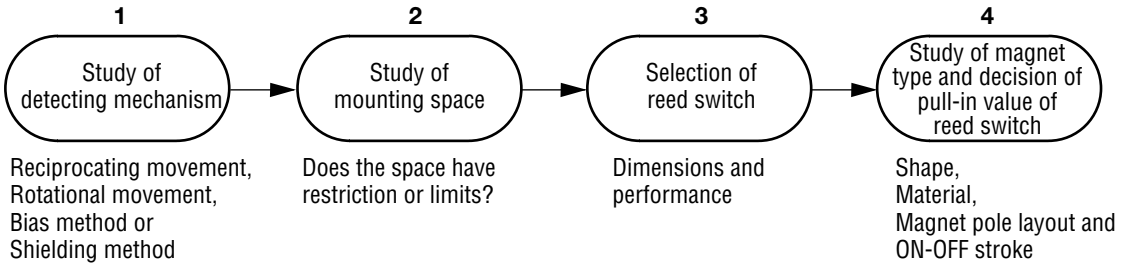

4-1 Permanent magnet drive method

The following four patterns 1) through 4) illustrate typical methods to drive the reed switch by a permanent magnet.

1) Reciprocating method

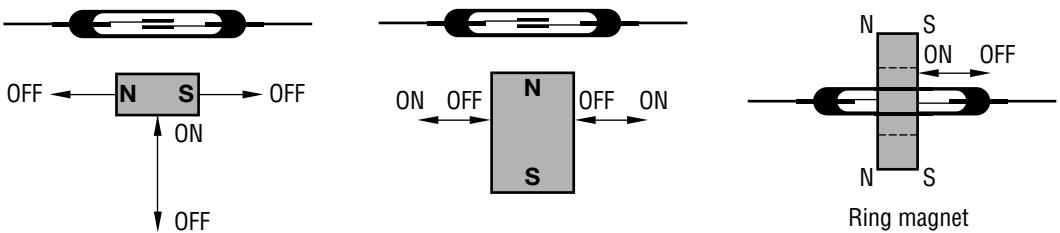

Figure 4.1

2) Rotational method

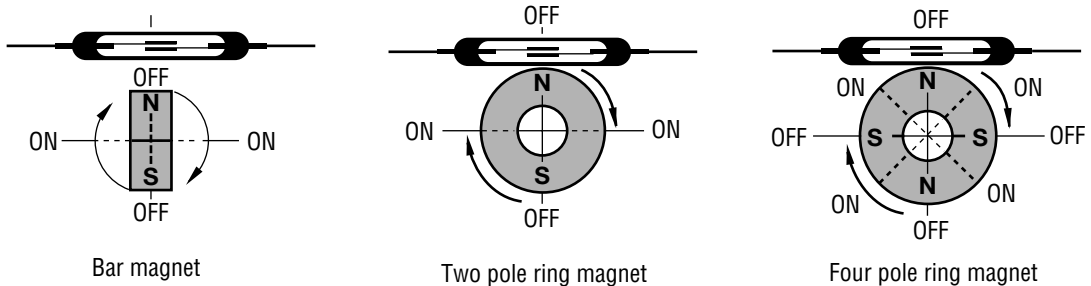
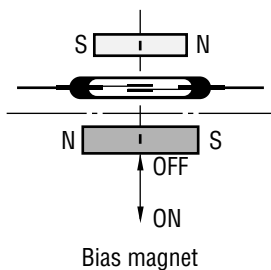

Figure 4.2

3) Bias method



4) Shielding method

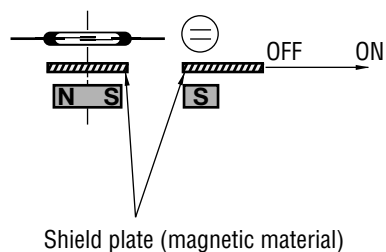

Figure 4.3

4-2 Permanent magnet drive characteristics

When a reed switch is operated by a permanent magnet, its ON-OFF domains will differ according to the type of the reed

switch, its pull-in and, drop-out values, read forming conditions as well as the permanent magnet material, its shape, and magnetizing conditions.

Typical drive characteristics are shown below.

(1) X - Y characteristic H (horizontal)

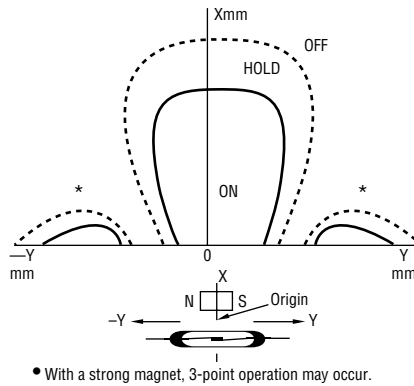

Figure 4.4

(2) X - Z characteristic H (horizontal)

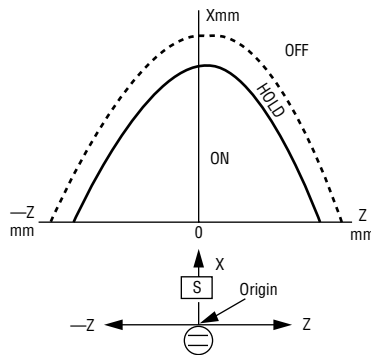

Figure 4.5

(3) X - Y characteristic V (vertical)

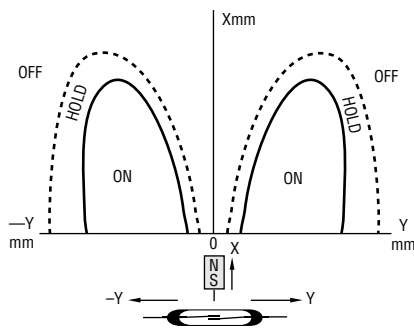

Figure 4.6



4-3 ORD225 magnet drive characteristics  
Example

Magnet:  $4 \times 5 \times 7$  mm  
Anisotropic barium ferrite  
Surface magnetic flux: 900 Gauss

Reed switch: ORD225  
Pull-in 30.9 (AT)  
Drop-out 17.9 (AT)

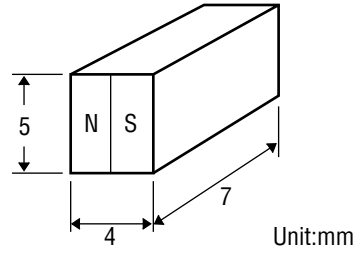

(1) X - Y characteristic H

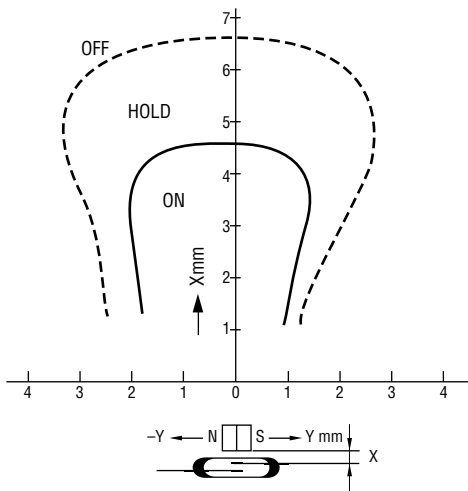

Figure 4.7

(2) X - Z characteristic H

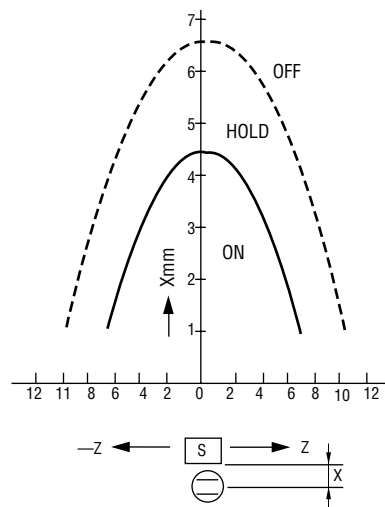

Figure 4.8

(3) Pull-in and drop-out values, operating point (4) X - Z characteristic V

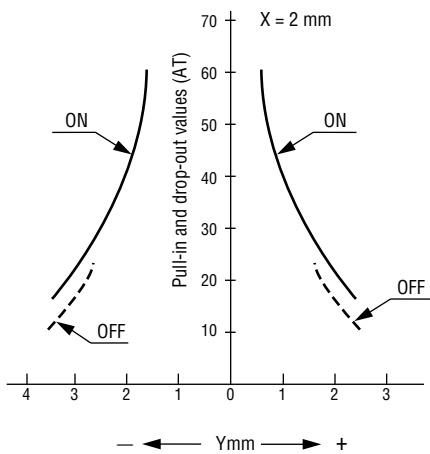

Figure 4.9

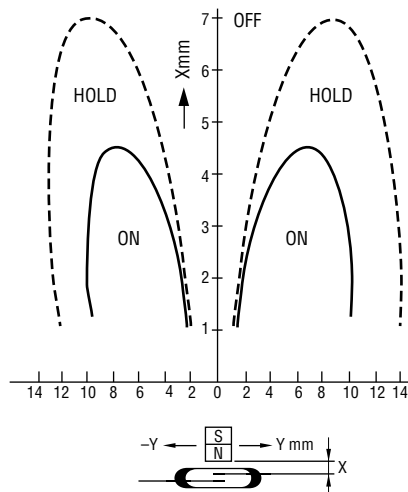

Figure 4.10

## REED SWITCH RELIABILITY

Reed switches play important roles in the recent marked progress in the development of electronics and mechatronics equipment. Important applications of reed switches cover a wide variety of fields such as those in communications equipment, office automation equipment, control equipment, and consumer electronics equipment and the demands for these devices are steadily increasing.

Under these conditions, for example, a failure in communications equipment can have incalculable influence. Now, it is the obligation of manufacturers to supply reliable and high quality products.

We are fully aware of our obligations in this regard. Accordingly, we have adopted a comprehensive quality assurance system with integrated product policy in development, manufacturing, marketing and sales. Moreover, we will expand our efforts to meet the demands for improvements in performance and reliability of the products.

We outline below our quality assurance system and the underlying concepts that enable us to supply reliable quality products. Furthermore, we explain the reliability testing methods and our original technology which we use to maintain the high reliability in our reed switch products.

### 1. Quality Assurance System and Underlying Concepts

The goals of the quality assurance system employed by we are as follows:

- Supply of high quality product
- On-time delivery
- Rational product cost
- Customer oriented product marketing.

The flow of product quality assurance consists of the following four stages:

- Product planning stage
- Development and prototype production stage
- Trial mass production stage
- Mass production stage.

This system is illustrated in the block diagram shown in Figure 1.1.

#### 1-1 Product planning stage

To manufacture products that meet market demands and satisfy customer needs, we carefully study functional and failure rate requirements, product applications, environments and other conditions. After these studies, we specify the material, structure and the sizes of the products planned. We then proceed to the design plan, manufacturing engineering plan, and process capacity requirement plan.

At this point, we prepare the development plans and time schedules.

#### 1-2 Development and prototype production stage

At this stage, we concretely establish the required structure, dimensions, processes and assembly techniques. Furthermore, actual prototype testing is carried out to ensure reliability.

Since most product quality is determined at the design stage, we build quality into the product design and pay careful attention to quality assurance during this stage. Specifically,

- (1) After completing the basic design, the design engineering, production engineering and product reliability departments perform design reviews.
- (2) Prototypes are subjected to repeated functional and reliability testing. At this point, characteristics and reliability are confirmed while the stability and capacity of manufacturing processes are also confirmed.

#### 1-3 Trial mass production stage

During this stage, various tests are performed to check the features and reliability mentioned above. These activities are aimed at the mass production level.

After confirming product quality, we prepare the various mass production standards and start mass production.

#### 1-4 Mass production stage

During the mass production stage, careful management of purchased materials and parts, facilities used during the manufacturing process, measuring equipment, manufacturing conditions and environment is necessary to ensure product quality stipulated during the designing stages.

In-process quality and lot assurance inspections are shown in Figure 1.2.

Following lot assurance inspections, the products are placed in storage awaiting shipment to customers. Standards are also set up for handling, storage and transportation during this period, to ensure that no product quality problems develop before the product reaches the customers.

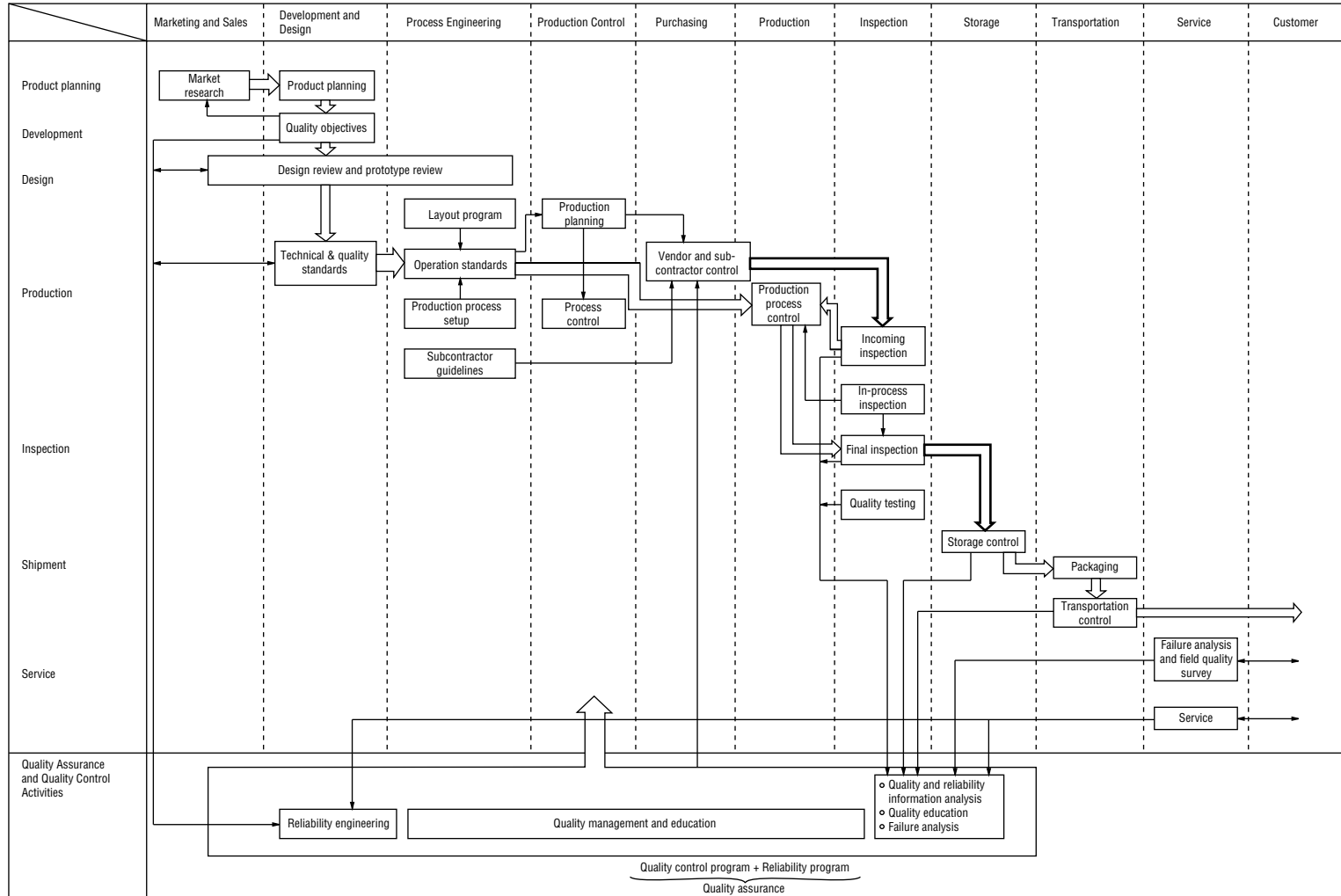

Figure 1.1 Quality assurance system

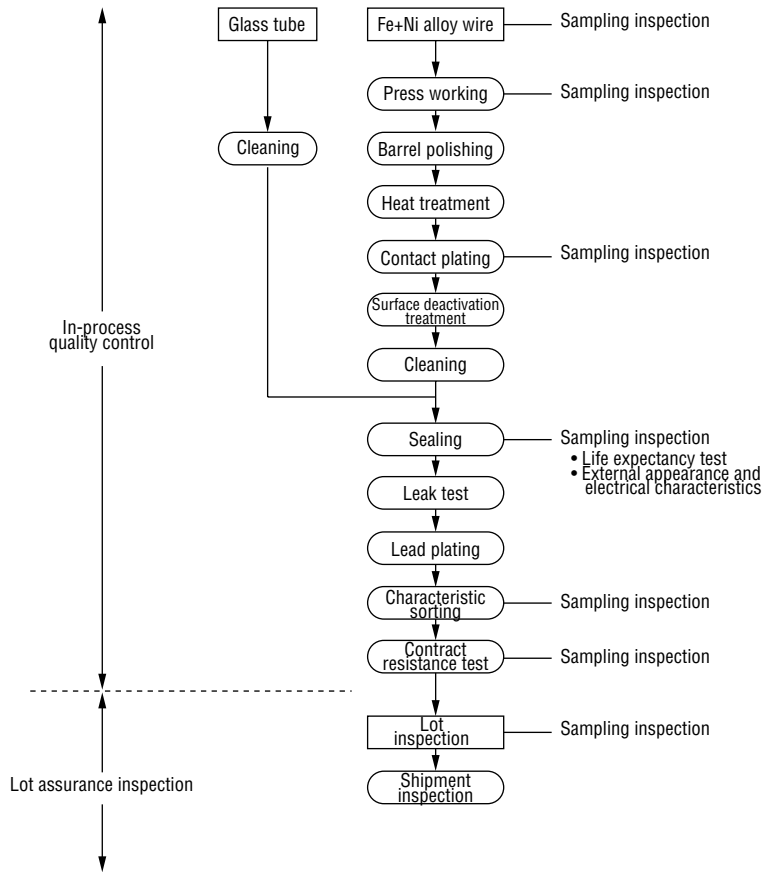

Figure 1.2 Quality control flow chart

All products are subjected to thorough quality checks as described above and shipped to the customers. If, by any chance, a failure does occur after delivery to the customers, defective products are processed and the problem is rectified immediately to minimize the inconvenience to the customers in accordance with the flow chart shown in Figure 1.3.

Quality improvement activities are employed to assure high quality product performance and reliability following the quality assurance and quality control flow shown in Figure 1.4.

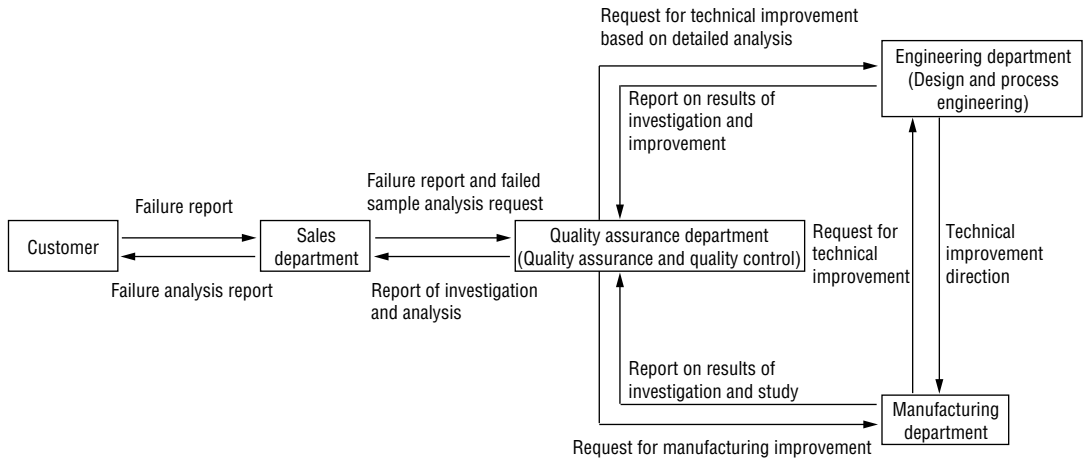

Figure 1.3 Failure report process flow chart

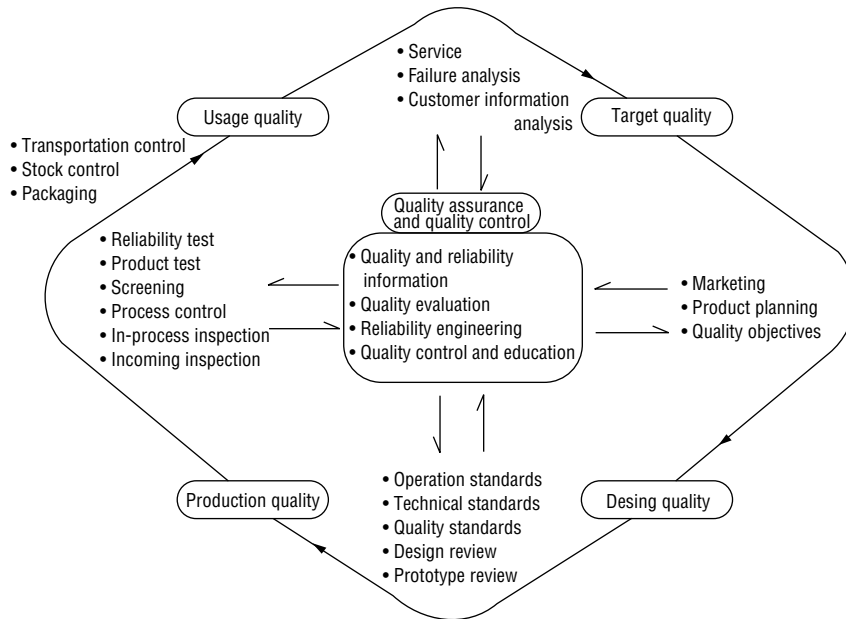

Figure 1.4 Quality assurance and quality control flow

## 2. Our Original Technology Supports High Reliability.

### 2-1 Deactivated rhodium contacts

Our reed switches are extremely reliable because of the use of rhodium as the contact material.

Rhodium has two superior properties for use as contact material. The first is its extreme hardness which is effective in preventing sticking. The second is the high melting point which remarkably reduces contact surface wear caused by joule heat and arc discharge. However, since rhodium belongs to the platinum group, it is absorptive and catalytic.

Therefore, rhodium-plated contacts adsorb organic impurities and form polymers during operations as shown in Figure 2.1. This greatly increases the contact resistance. In the low-level load operation, this phenomenon is particularly noticeable.

In order to deactivate the rhodium-plated contact, we have developed a unique high temperature oxygen treatment. This technique makes the organic impurities built on the surface burned with oxygen and forms oxygen molecule layer on the contact which in turn provide stable contact resistance. This unique method won the highest prize (Schneider Award) at the 21st National Relay Conference in Oklahoma, USA, in 1973.

Our technology is valued highly, and at the 36th and 38th Annual National Relay Conferences we also received the Schneider Awards for research on reed switch contact surface phenomena.

Our patents have been registered in Japan (Pat. No. 916386), USA (Pat. No. 3857175) and West Germany (Pat. No. 2303587).

### 2-2 High performance, automatic sealing equipment

Sealing is the process of forming the reed switch from the assembly of pressed and plated reed and glass tube. This is one of the most important processes which demands severe quality control and management. At the time of sealing, working temperature reaches 1000 °C which makes the glass tube impurities evaporate and

causes the reed switch contact surface to be contaminated. To prevent the effects of these phenomena, we have developed severe standards for selection of glass material. In addition we also use unique technology for automatic sealing. Improvements in manufacturing method such as these enable us to produce extremely high quality reed switches.

### 2-3 Magnetic flux scanning test (FS test) for measuring contact resistance

Sealing processes are performed under severe quality control and management. However, there is still a slight possibility for magnetic foreign particles to enter into the glass tube. We have conducted extensive research into the detection of microparticles and we developed the "Magnetic Flux Scanning Test" as an extremely high reliability technique for measuring contact resistance.

A general description is shown in Figure 2.2 where the magnetic attractive force from multiple layers of coils cause the magnetic foreign particles to move to the contact part of the reed switch. During check of the contact resistance, foreign particles are detected.

Since we use this unique technology, we have succeeded in making rapid progress toward improving reed switch reliability.

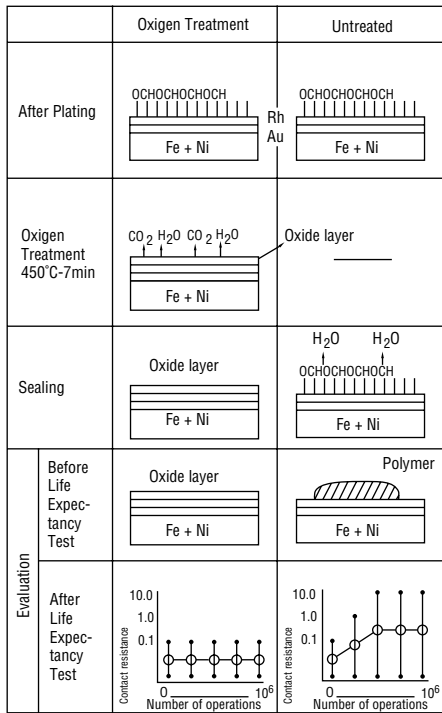

Figure 2.1

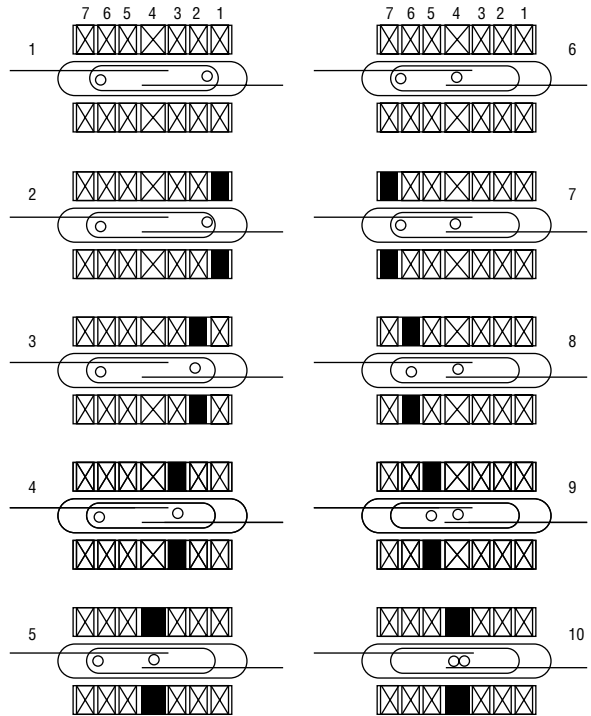

Figure 2.2 Magnetic Flux Scanning Test (FS Test)

### 3. Reliability Testing Methods

Parameter	Specification	Unit	Test conditions
Temperature and Humidity Cycle	-10 to 65 (80 to 98)	°C (%)	MIL-STD-202F 106E (Refer to Figure 2.3)
Temperature Cycle	-55 to 125	°C	Chart is shown in Figure 2.4.
High Temperature Storage	125	°C	500H
Low Temperature Storage	-40	°C	500H
Shock Resistance	30	G	MIL-STD-202F 213B Condition J
Vibration Resistance	20	G	MIL-STD-202F 204D Condition D



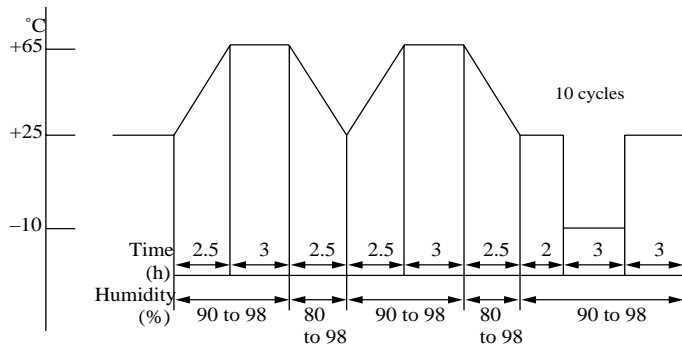

Figure 2.3 Temperature and humidity cycle chart

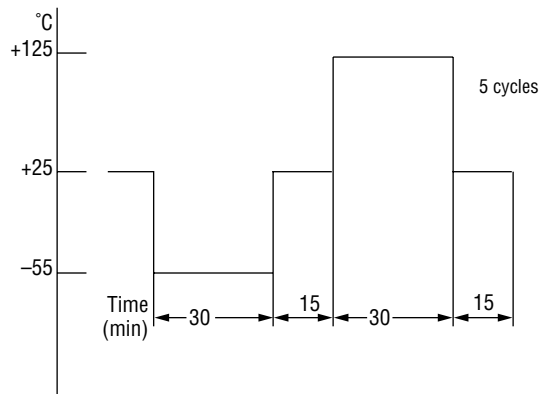

Figure 2.4 Temperature cycle chart

PRECAUTIONS AND APPLICATIONS

1. Contact Protection Circuit

When a reed switch is to be connected to the inductive load or the load where surge current or rush current flows (such as capacitance load, lamp, long cable, etc.), the following contract protection circuits are also required for the red switch.

1-1 Inductive loads

In case an electromagnetic relay, electro-magnetic solenoid, or electromagnetic counter which has inductance component is provided as a load in a circuit, the energy stored in the inductance will cause an inverse voltage when the reed contacts break. The voltage, although dependent on the inductance value, sometimes reaches as high as several hundred volts and becomes a major factor to deteriorate the contacts. In order to prevent this many protection circuits are provided, typical examples of which are shown in Fig. 1.1.

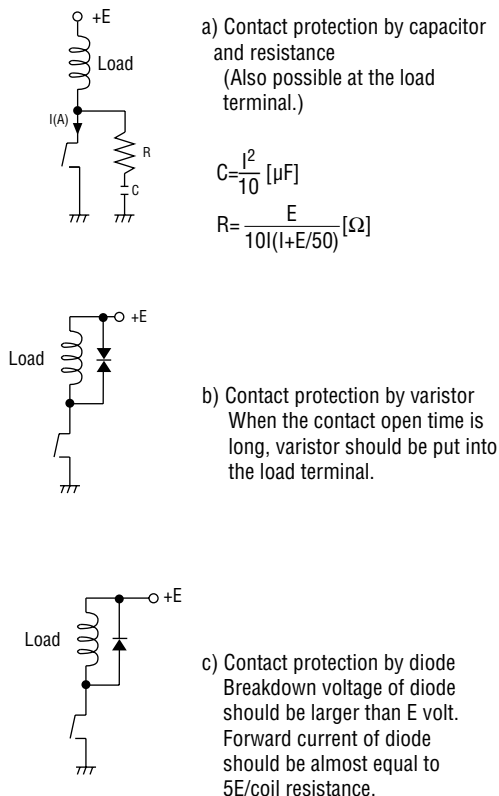

Figure 1.1

1-2 Capacitive loads

In case a capacitor is provided in series or in parallel with the reed switch contacts in a closed circuit, the rush current which flows at the time of charge and discharge of the capacitance will cause much deterioration of the reed contacts. Fig. 1.2 shows typical examples of the protection circuits to prevent the rush current.

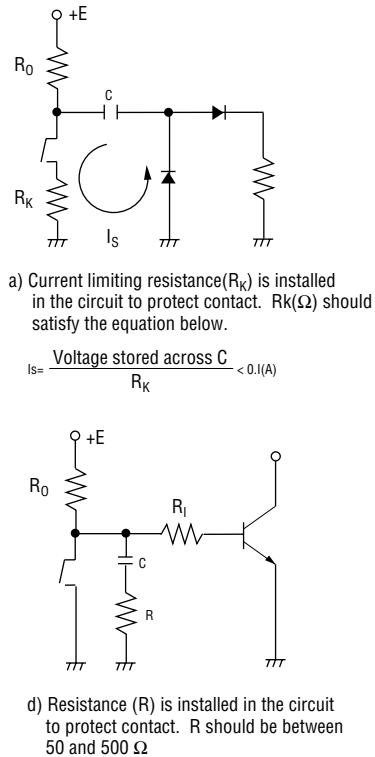

Figure 1.2

1-3 Lamp load

In case of the lamp load, a tungsten filament lamp is generally used. The tungsten filament lamp features that its resistance is small immediately before it is switched on and will become larger after switched on, followed by lighting with steady-state current. If the reed switch is used for switching in this lamp circuit, the rush current (5 to 10 times the steady-state current) will flow in the contacts immediately after the lamp being turned on, and often cause melting or sticking of the reed contacts. The circuit with a lamp load is, therefore, considered similar to a circuit

with a capacitor where large current flows to charge the capacitor, thus requiring the contact protection circuit. Fig. 1.3 shows examples of protection circuits.

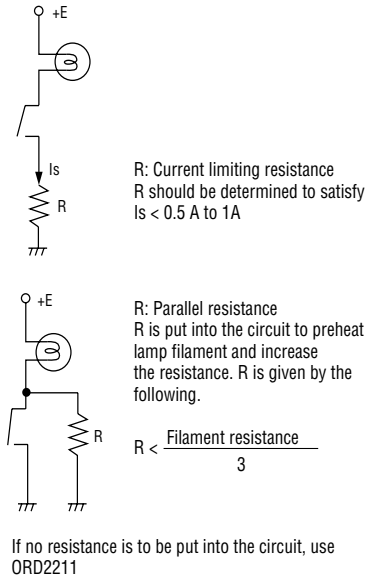
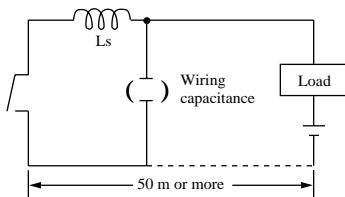

Figure 1.3

1-4 Wiring capacitance

When wiring a load and reed switch over long distance, electrostatic capacitance arising from the cable can influence the reed switch contact. Therefore, inductance  $L_s$  should be used.  $L_s$  value differs according to the load current but should be in the range of 0.5 to 5 mH.



2. Reed Switch Lead Forming

When reed switches are used, usually the leads are cut or bent. However, precautions should be taken when performing these processes.

- (1) Cutting and bending positions must be determined with reference to the center of the contact or to the end of the lead. If the position is measured from the end of the glass tube, the contact center position may be moved.
- (2) When in cutting or bending the leads, be sure to protect the sealing portions. As shown in Figure 2.1, the lead should be placed firmly by a jig.
- (3) After the process, confirm that there is no crack or chipping in the glass tube.

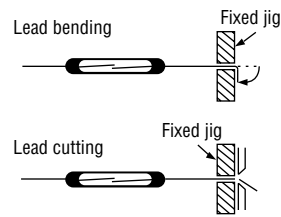

Figure 2.1

2-1 Cutting the leads

Since the leads of a reed switch comprise part of the magnetic circuit, shortening the leads by cutting will cause the required ampere turns for pull-in and drop-out to increase as shown in Fig. 2.2. Here in this figure, a standard coil was used in making measurements and there may be differences when the reed switch is driven by a permanent magnet depending on the difference of the shape of magnet and orientation of magnetization. Therefore, it is necessary to actually examine the change of the pull-in and drop-out values by the magnet and drive method to be used.

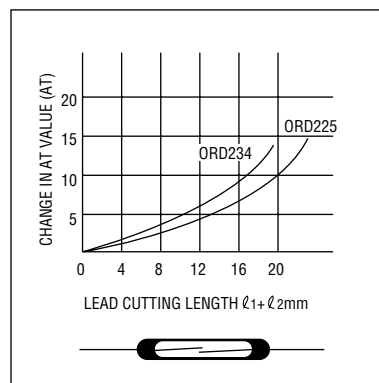

Figure 2.2

2-2 Bending the leads

As in the case of cutting the leads, influence on the pull-in and drop-out characteristics must be checked by actually using the magnet and the driving method planned.

2-3 Measuring the electrical characteristics of reed switches after cutting or bending.

When the leads of a reed switch are cut, it is not possible to measure electrical characteristics by using a standard test jig. However, it is possible to measure these characteristics after processing if a special jig is made. It is also possible to measure electrical characteristics of the reed switch with a bent lead by using the jig similar to the one used for a reed switch with a cut lead. However, when both leads are bent, the reed switch cannot be inserted into a coil and therefore cannot be measured.

3. Reed Switch Mounting

Generally, a reed switch is mounted by soldering or welding. When the mounting space (including its vicinity) is non-magnetic, there is no influence on operation but when the material is magnetic, operation characteristics do change. Therefore, it is necessary to check these in consideration of the assembling conditions.

3-1 Soldering

Leads are tin plated and are soldered ordinarily (250 to 300°C). When soldering, keep the soldering point at least 1 mm away from the glass end. In addition, there is also a danger of causing the glass tube to be damaged by heat if the soldering is done for a long time. Keep the process to less than five seconds.

3-2 Welding

When welding, also keep the welding point at least 1 mm away from the glass end. When using a large power supply for welding, heat generated in lead may cause damage to the glass tube. Precautions to prevent this are necessary.

Welding current may also induce magnetic field and cause the reed switch to operate. Therefore, it may introduce welding current to the contact and contact may be melted. Precautions are also necessary.

3-3 Ultrasonic welding

Be very careful when using ultrasonic welding methods to weld reed switches or using ultrasonic welder in the vicinity of a reed switch.

The ultrasonic can change the contact gap and the characteristics of the reed switch.

3-4 Mounting on a printed circuit board

When mounting on a printed circuit board, the reed switch should float on the board as shown in Figure 3.1 or hole should be opened in the printed circuit board to prevent the glass from touching the board surface. Otherwise, it is possible to cause a damage to the glass tube because of physical shocks or other adverse elements applied externally to it.

4. Reed Switch Resin Mold

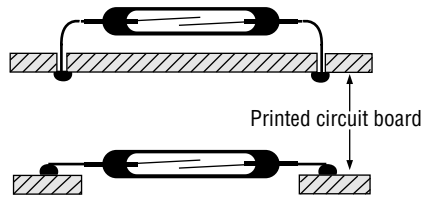

Figure 3.1

When reed switches are molded with resin, it is possible for the resin stress to break or damage the glass tube. Therefore, the resin should be selected carefully. Moreover, it is necessary to perform temperature cycle testing to ensure selection of safe resin material.

On the other hand, there is no problem if silicone or other soft resin is used.

5. Dropping Reed Switches

Avoid dropping reed switches. If a reed switch is dropped onto a hard surface from a height more than 30 cm, it is possible to cause the characteristics to change. If a reed switch has been dropped, carefully inspect its characteristics and exterior appearance before use.

If a reed switch has been subjected to shock more than 30 G, the pull-in value may change.

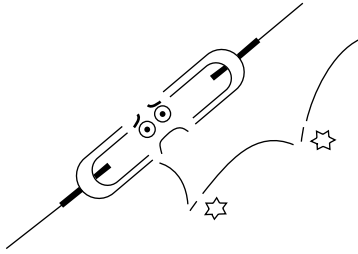

Figure 3.2

#### 6. Relation to Characteristic Values Given by Other Makers

Measurement methods are manufacture dependent. Therefore, the pull-in value may be different depending on the measurement conditions (standard coils and overall length of the reed switch are different). Accordingly, it is necessary to correlate the characteristics.

#### 7. Certified Pull-in Value for Reed Switches

The pull-in value (four digits) shown on the reed switch package is selected range values. The certified pull-in value for this selected range has a tolerance of  $\pm 2AT$ .

Example: Certified pull-in value for ORD 211 (2025) is 18 to 27 AT.

#### 8. Specifications

Specifications given here are subject to change for improvement without notice to the users. Please make sure that you have the latest values and specifications before actual use.

## DESCRIPTION OF SYMBOLS AND TERMS

## REED SWITCH

## DESCRIPTION OF SYMBOLS AND TERMS

Following is generally used terms regarding the basic operating characteristics of the reed switches.

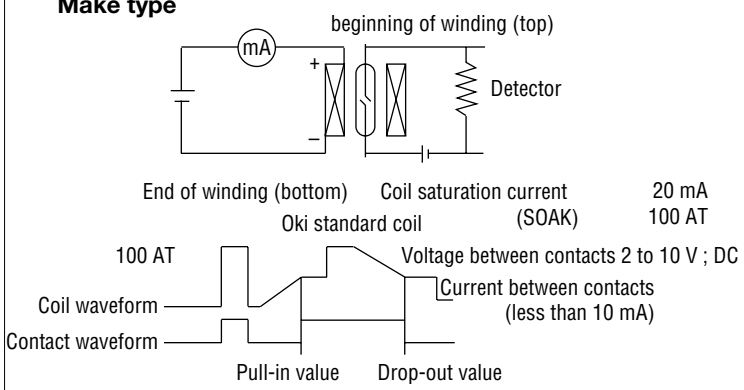
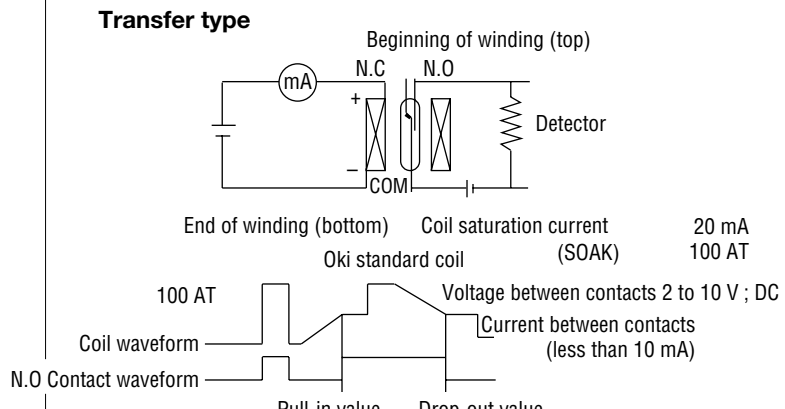
Term	Symbol	Unit	Description and Test Methods
Pull-in Value	PI	AT	<ul style="list-style-type: none"> <li>This is the most important operating characteristic of a reed switch. It is given as the product of the energizing current for the coil necessary to operate the switch and the number of turns of the coil winding.</li> <li>This is the sensitivity of reed switch. High sensitivity means low pull-in value.</li> </ul>
Drop-out Value	DO	AT	<ul style="list-style-type: none"> <li>Drop-out value is obtained by taking the product of the value of the current flowing in the coil at the time when the contacts are released and the number of turns of the coil windings. Drop-out value is correlative to pull-in value and is a secondary value.</li> <li>Test method (1) Measurement circuits of pull-in and drop-out values</li> </ul> <p><b>Make type</b></p>  <p>Coil saturation current (SOAK) 20 mA Oki standard coil 100 AT</p> <p>100 AT</p> <p>Coil waveform</p> <p>Contact waveform</p> <p>Pull-in value</p> <p>Drop-out value</p> <p>Voltage between contacts 2 to 10 V ; DC Current between contacts (less than 10 mA)</p> <p>Current at time of operation x Number of turns in standard coil (500 AT); Indicated in AT</p> <p><b>Transfer type</b></p>  <p>Beginning of winding (top)</p> <p>End of winding (bottom)</p> <p>N.C.</p> <p>N.O.</p> <p>COM</p> <p>Coil saturation current (SOAK) 20 mA Oki standard coil 100 AT</p> <p>100 AT</p> <p>Coil waveform</p> <p>N.O. Contact waveform</p> <p>Pull-in value</p> <p>Drop-out value</p> <p>Voltage between contacts 2 to 10 V ; DC Current between contacts (less than 10 mA)</p> <p>Current at time of operation x Number of turns in standard coil (500 AT); Indicated in AT</p>

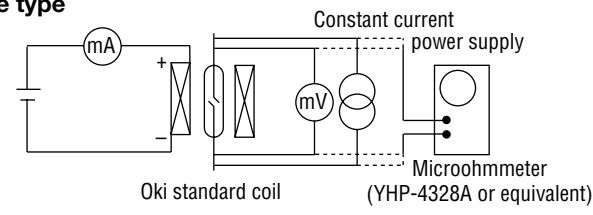
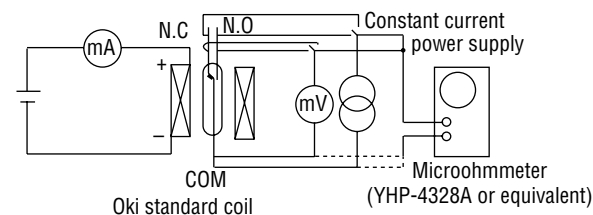
Term	Symbol	Unit	Description and Test Methods
			<p>Note: Measure after making sure that the center of the coil and the center of the reed switch contacts are aligned. Initially, apply soak current (100 AT) then return to zero (AT). Next, apply the current in the same direction and measure it. The polarity of the current applied to the coil should make the direction of the energized magnetic field to be the same as the direction of terrestrial magnetism. (The leading end of the coil-wire at the top should have positive polarity.)</p>
Contact Resistance	CR	mΩ	<p>•Contact resistance is the resistance between contacts when the contacts are closed and includes conductor resistance.</p> <p>•Test method (2) Measurement circuit of contact resistance</p> <p><b>Make type</b></p>  <p style="text-align: center;">Oki standard coil      Microohmmeter (YHP-4328A or equivalent)</p> <p style="text-align: center;">{ Applied voltage for measurement (less than 10 V DC) }          { Current for measurement (less than 10 mA) } or Microohmmeter</p> <p style="text-align: center;">Coil current    20 mA    (100 AT)</p> <p><b>Transfer type</b></p>  <p style="text-align: center;">Oki standard coil      Microohmmeter (YHP-4328A or equivalent)</p> <p style="text-align: center;">{ Applied voltage for measurement (less than 10 V DC) }          { Current for measurement (less than 10 mA) } or Microohmmeter</p> <p style="text-align: center;">Coil current    20 mA(100 AT) N.O          0 mA( 0 AT) N.C</p>
Breakdown Voltage		V	<p>•Specifies a maximum value of transient voltage over the contacts caused by surge current or other external factors. Below this rated value, the reed switch operates without destruction of its contact insulation resistance.</p>

Term	Symbol	Unit	Description and Test Methods
			<ul style="list-style-type: none"> <li>•Test method: MIL-STD-202F METHOD301 Breakdown voltage shown here is the value measured for the switch whose pull-in value is 20 AT or more. The criterion of leak current is less than 0.1 mA for one minute.</li> </ul>
Insulation Resistance		V	<ul style="list-style-type: none"> <li>•Insulation resistance is the resistance between lead ends and the resistance against leak current across the reed switch glass tube or its surface.</li> <li>•Test method: MIL-STD-202F METHOD302 Measurement is made by using a DC 100 V super megger.</li> </ul>
Electrostatic Capacitance		pF	<ul style="list-style-type: none"> <li>•Electrostatic capacitance is the value of capacitance between open contacts. The overlap of reed switch contacts is uniform. Therefore, when the contact gap becomes large, accompanying an increase in pull-in value, the electrostatic capacitance becomes small.</li> <li>Erectrostatic capacitance is measured at 1 MHz-0.1 V</li> </ul>
Contact Rating		W VA	<ul style="list-style-type: none"> <li>•Contact rating is the maximum product of the voltage and current at which contacts operate and contact switching performance is stable. This is a very important value. In order to anticipate constant life expectancy and assure reliability when switching is performed, the contact rating must not be exceeded and it is less than the product of (maximum switching voltage) X (maximum switching current).</li> <li>Contact rating is also called contact capacitance or contact power allowance.</li> </ul>
Maximum Switching Voltage		V A	<ul style="list-style-type: none"> <li>•Maximum switching voltage is the maximum voltage at which contacts can be switched. It is used as a reference value of voltage for contact switching performance. In order to anticipate constant life expectancy and assure reliability when switching is performed, the maximum switching voltage must not be exceeded.</li> <li>Maximum switching voltage is also called rated contact voltage, maximum working voltage, or allowable contact voltage.</li> </ul>
Maximum Switching Current			<ul style="list-style-type: none"> <li>•Maximum switching current is the maximum current at which contacts can be switched. It is a reference value of current for contact switching performance. In order to anticipate constant life expectancy and assure reliability when switching is performed, the maximum switching current must not be exceeded.</li> <li>Maximum switching current is also called rated contact current, maximum on-off contact current, or rated on-off current.</li> </ul>

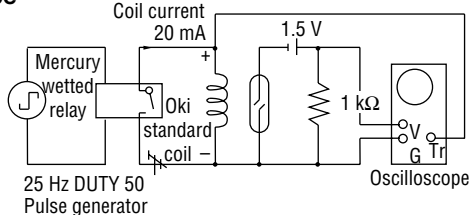
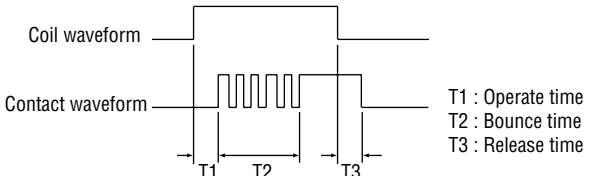
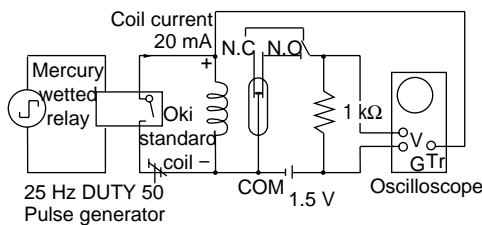

Term	Symbol	Unit	Description and Test Methods
Maximum Carry Current		A	<p>•Maximum carry current is the maximum current which can flow continuously over the closed contact. In order to anticipate constant life expectancy and assure reliability, the maximum switching carry current must not be exceeded. Maximum carry current is also called rated contact carry current or allowable contact carry current.</p>
Operate Time	Top	ms	<p>•Operate time means the time required for the contacts to close after applying voltage to the energizing coil. Unless otherwise specified, operate time does not include bounce time.</p>
Bounce Time	Tb	ms	<p>•Bounce time means the time between the time when the contacts closed initially and the time when they come to close stably.</p>
Release Time	Tis	ms (μs)	<p>•Release time is the elapsed time before the contacts are opened after the coil energizing voltage is removed.</p> <p>Test method (3) Time characteristics measurement circuit</p> <p><b>Make type</b></p>   <p><b>Transfer type</b></p> 

Term	Symbol	Unit	Description and Test Methods																																								
			<p style="text-align: right;">                     N.O T1 : Operate time                      T2 : Bounce time                      T3 : Release time                      N.C T4 : Operate time                      T5 : Release time                      T6 : Bounce time                      T7 : Transfer time (N.O→N.C)                      T8 : Transfer time (N.C→N.O)                 </p> <p>Note: Measure after making sure that the center of the coil and the center of the reed switch contacts are aligned.</p>																																								
Resonant Frequency		Hz	<ul style="list-style-type: none"> <li>Resonant frequency is the vibration frequency inherent to the reed switch. If the reed switch is subjected to vibrations which have the similar frequency to the resonant frequency, it may cause misoperation.</li> </ul>																																								
Maximum Operating Frequency		Hz	<ul style="list-style-type: none"> <li>Maximum operating frequency is the maximum drive frequency. The reed switch can be operated with a frequency higher than the maximum operating frequency. However, operation with such a frequency may cause an endless bouncing.</li> </ul>																																								
Standard Coil		Number	<ul style="list-style-type: none"> <li>The standard coil is the coil provided for measuring reed switch characteristics. The standard coil varies depending on the type of the reed switch.</li> </ul> <p><b>Standard coil specifications</b></p> <table border="1" style="width: 100%; border-collapse: collapse; text-align: center;"> <thead> <tr> <th>Number</th> <th>No.3</th> <th>No.6</th> <th>No.8</th> <th>No.10</th> </tr> </thead> <tbody> <tr> <td>A</td> <td>21</td> <td>15</td> <td>10</td> <td>10</td> </tr> <tr> <td>B</td> <td>25</td> <td>19</td> <td>12</td> <td>26</td> </tr> <tr> <td>C</td> <td>φ4.6</td> <td>φ3.7</td> <td>φ3.3</td> <td>φ4.6</td> </tr> <tr> <td>D</td> <td>φ3.5</td> <td>φ2.9</td> <td>φ2.3</td> <td>φ3.5</td> </tr> <tr> <td>E</td> <td>φ11.0</td> <td>φ11.0</td> <td>φ11.0</td> <td>φ16.0</td> </tr> <tr> <td>Coil Resistance (Number of turns)</td> <td>500 Ω (5000T)</td> <td>450 Ω (5000T)</td> <td>600 Ω (5000T)</td> <td>550 Ω (5000T)</td> </tr> <tr> <td>Measured Reed Switch</td> <td>ORD229 ORD2210 ORD234 ORD234V ORT233</td> <td>ORD219 ORD221 ORD228VL ORD2211 ORD2212</td> <td>ORD211 ORD213 ORD214</td> <td>ORT551</td> </tr> </tbody> </table>	Number	No.3	No.6	No.8	No.10	A	21	15	10	10	B	25	19	12	26	C	φ4.6	φ3.7	φ3.3	φ4.6	D	φ3.5	φ2.9	φ2.3	φ3.5	E	φ11.0	φ11.0	φ11.0	φ16.0	Coil Resistance (Number of turns)	500 Ω (5000T)	450 Ω (5000T)	600 Ω (5000T)	550 Ω (5000T)	Measured Reed Switch	ORD229 ORD2210 ORD234 ORD234V ORT233	ORD219 ORD221 ORD228VL ORD2211 ORD2212	ORD211 ORD213 ORD214	ORT551
Number	No.3	No.6	No.8	No.10																																							
A	21	15	10	10																																							
B	25	19	12	26																																							
C	φ4.6	φ3.7	φ3.3	φ4.6																																							
D	φ3.5	φ2.9	φ2.3	φ3.5																																							
E	φ11.0	φ11.0	φ11.0	φ16.0																																							
Coil Resistance (Number of turns)	500 Ω (5000T)	450 Ω (5000T)	600 Ω (5000T)	550 Ω (5000T)																																							
Measured Reed Switch	ORD229 ORD2210 ORD234 ORD234V ORT233	ORD219 ORD221 ORD228VL ORD2211 ORD2212	ORD211 ORD213 ORD214	ORT551																																							



**APPLICATION NOTES**

The potential applications for reed switches are very broad. The main applications for reed switches are in automotive electronic devices, various types of instruments and testers, household appliances and so forth.

Here, some actual examples of reed switch applications are provided.

Reed switch application examples – I

Reciprocating operation

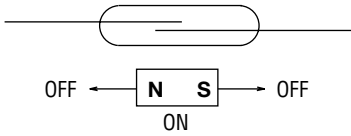

Reciprocating operation

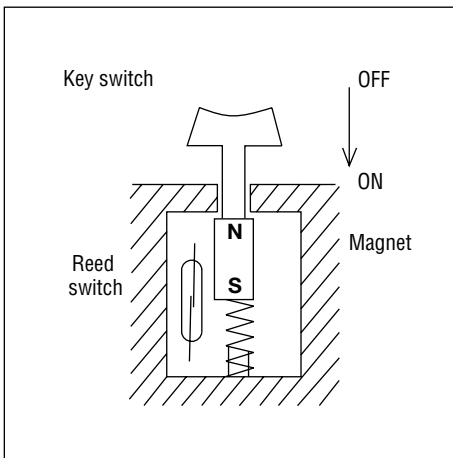
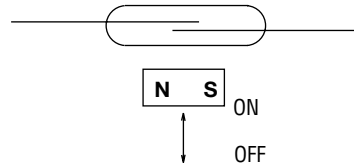

Application examples: Various types of button switches  
Keyboard

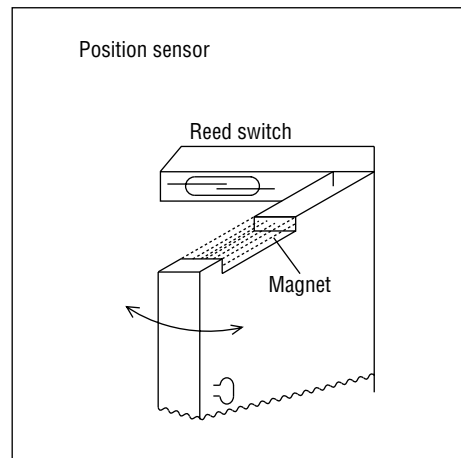

Application examples: Various types of door sensors  
Security system

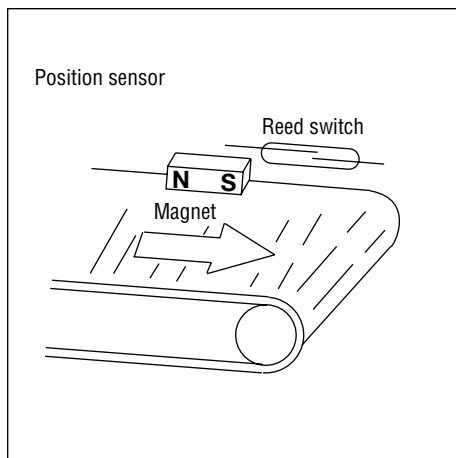

Application examples: Various types of position sensors  
Conveyor control

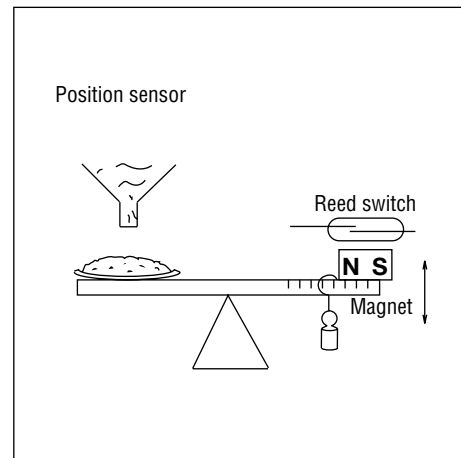

Application examples: Automatic balance

Reed switch application examples – II

position sensor

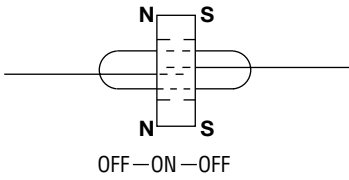

Rotating operation

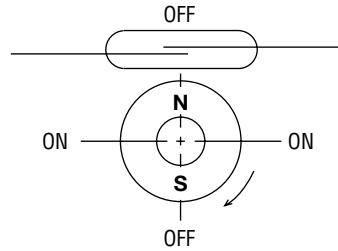

2

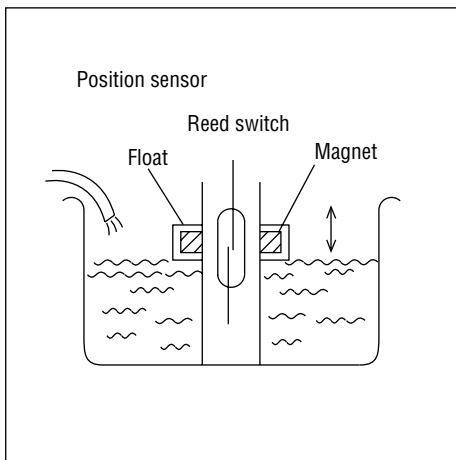

Application examples: Liquid level sensor  
Various float switches

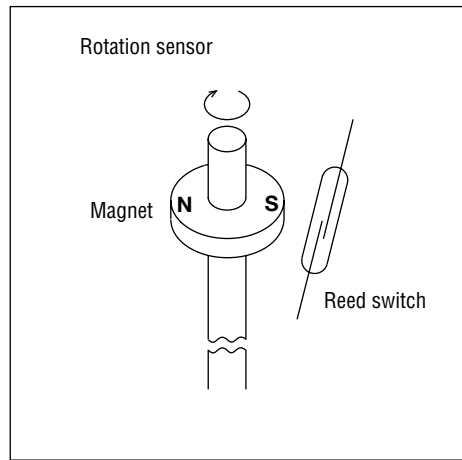

Application examples: Various types of rotation sensor

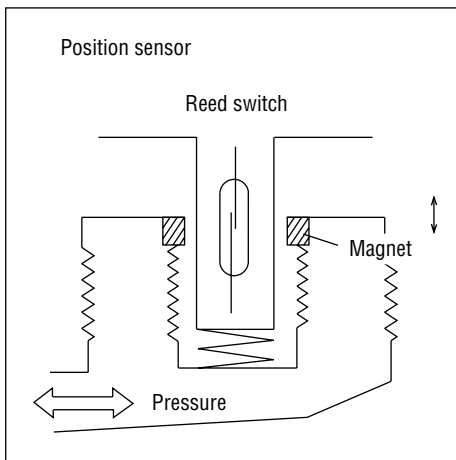

Application examples: Pressure sensor  
Wind pressure sensor

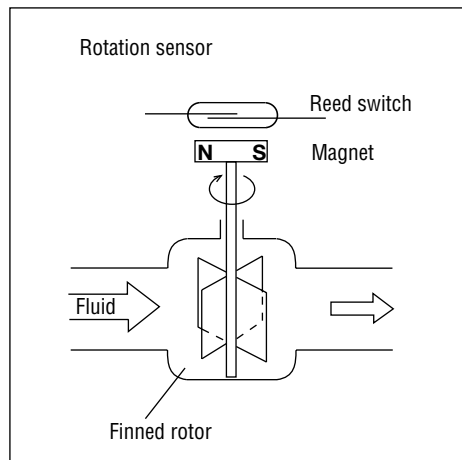

Application examples: Various types of fluid level sensor  
Flow measurement Instruments for water, gas, and wind

Reed switch application examples – III

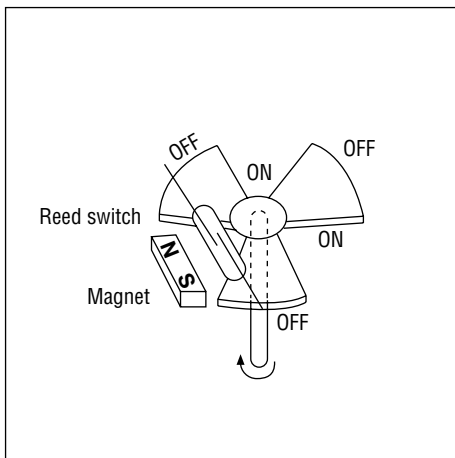
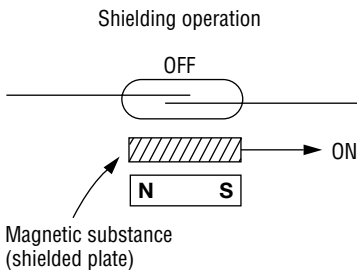

Application examples: Pulse generator

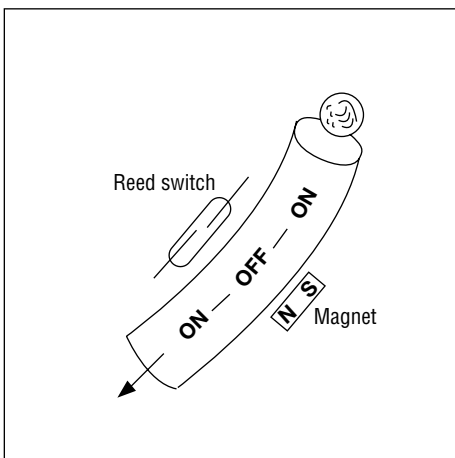

Application examples: Detecting the passing of various types of magnetic substances

Miscellaneous reed switch application examples

- ☆ Temperature sensor (Combination of thermal ferrite)

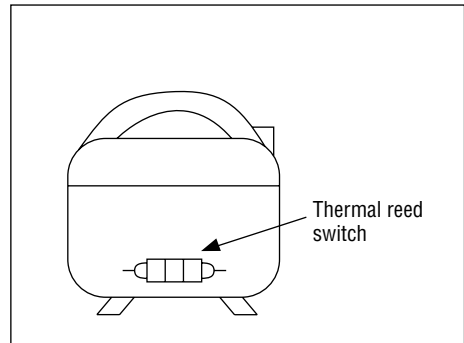

Application examples: Electronic cooker  
Heat detector

- ☆ Tilt detection

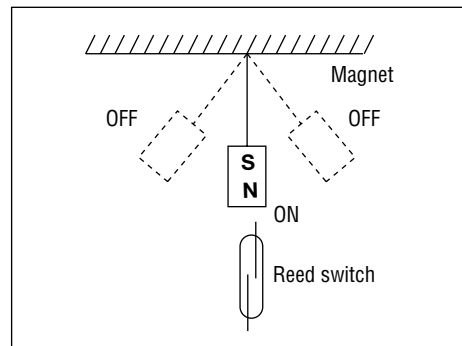

Application examples: Security system  
Earthquake sensor

- ☆ Security system

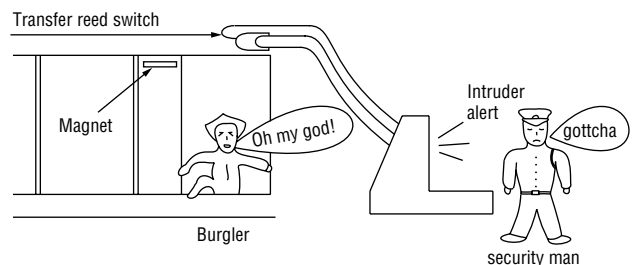

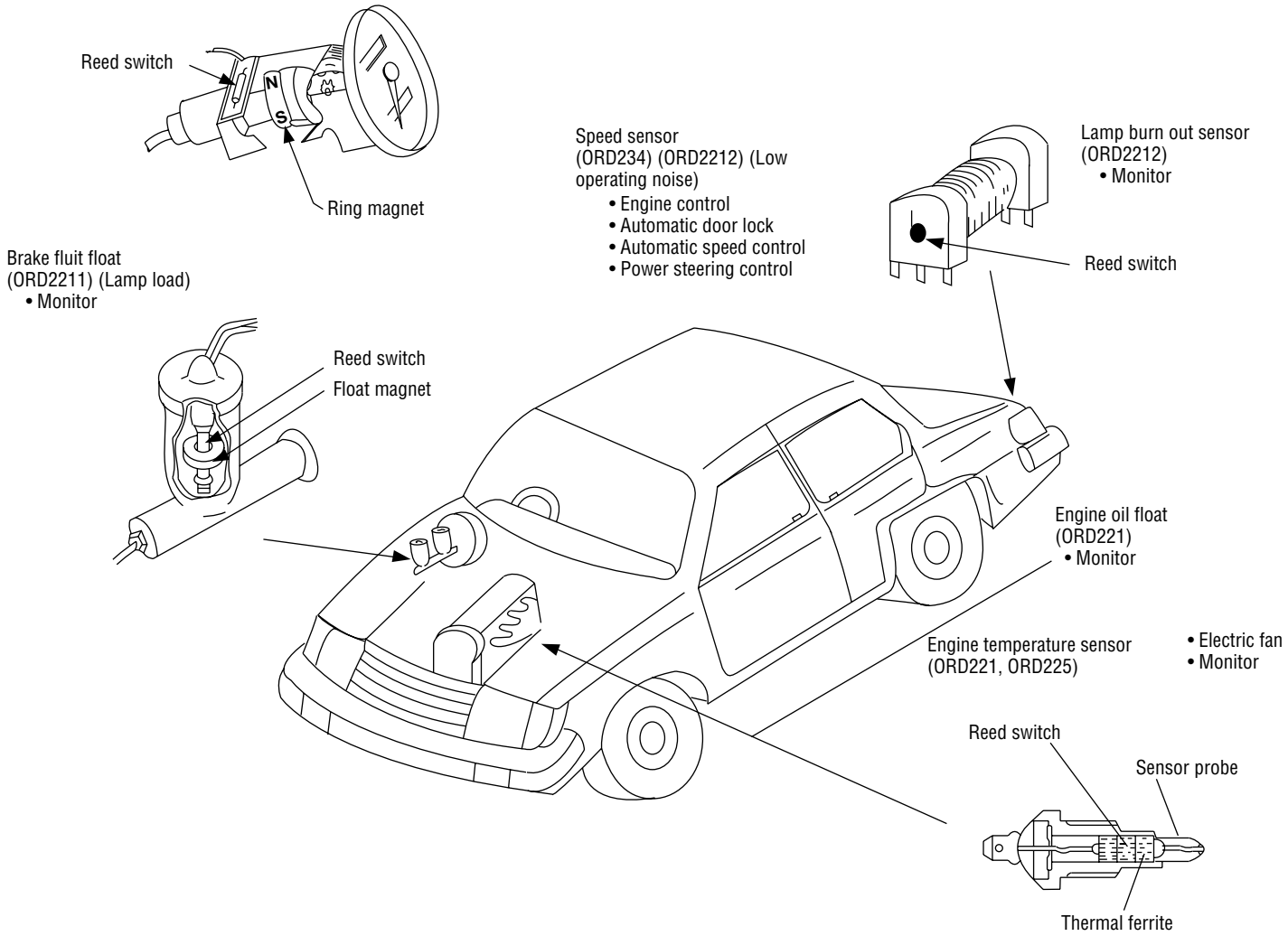

Reed switch application examples (automobile)





# REED SWITCH

## ORD211

**General Purpose Ultraminiature (Low-level Load 24 V Max.)**

### GENERAL DESCRIPTION

The ORD211 is a small single-contact reed switch designed for general control of low-level loads less than 24 V. The contacts are sealed within the glass tube with inert gas to maintain contact reliability.

### Features

- (1) Reed contacts are hermetically sealed within a glass tube with inert gas and do not receive any influence from the external atmospheric environment.
- (2) Quick response
- (3) The structure comprises an operating system and electrical circuits coaxially. Reed switches are suited to applications in radio frequency.
- (4) Reed switches are compact and light weight.
- (5) Superior corrosion resistance and wear resistance of the contacts assures stable switching operation and long life.
- (6) With a permanent magnet installed, reed switches economically and easily become proximity switches.

### External Dimensions (Unit:mm)

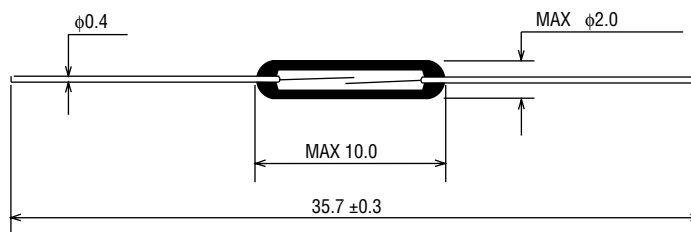

### APPLICATIONS OF REED SWITCHES

1. Automotive electronic devices
2. Control equipment
3. Communication equipment
4. Measurement equipment
5. Household appliances

**ELECTRICAL CHARACTERISTICS**

Parameter	Symbol	Condition	Rated Value			Unit
			Min.	Typ.	Max.	
Pull-in Value	PI	—	10	—	40	AT
Drop-out Value	DO	—	5	—	—	AT
Contact Resistance	CR	—	—	—	100	mΩ
Breakdown Voltage	—	—	150	—	—	VDC
Insulation Resistance	—	—	10 <sup>9</sup>	—	—	Ω
Electrostatic Capacitance	—	—	—	—	0.2	pF
Contact Rating	—	—	—	—	1.0	VA
Maximum Switching Voltage	—	—	—	—	24 <sup>DC</sup> <sub>AC</sub>	V
Maximum Switching Current	—	—	—	—	0.1	A
Maximum Carry Current	—	—	—	—	0.3	A

3

(1) Drop-out vs. Pull-in

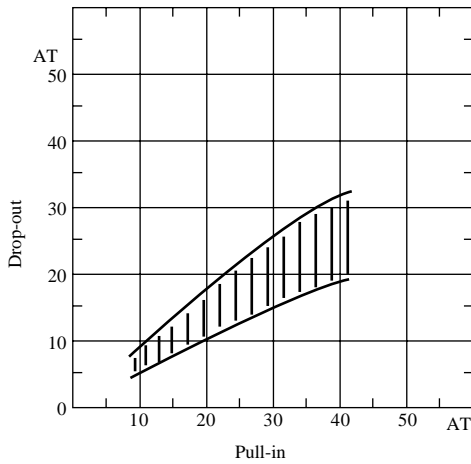

(2) Contact resistance

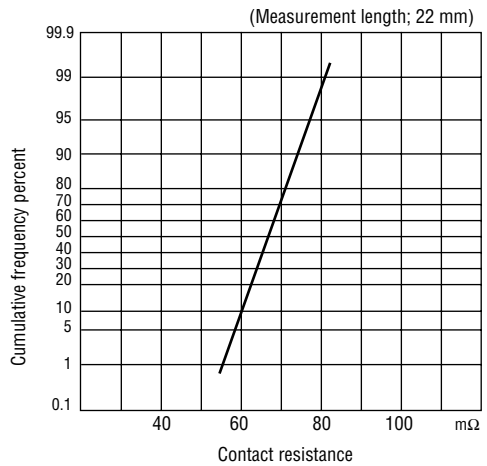

(3) Breakdown voltage

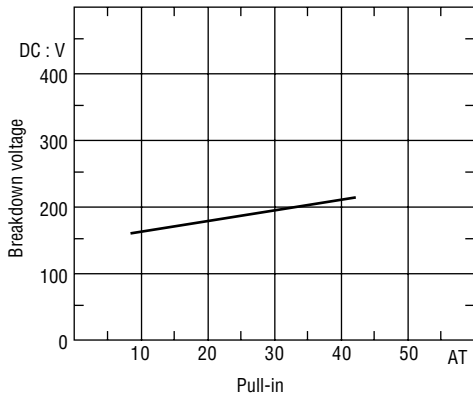

(4) Insulation resistance

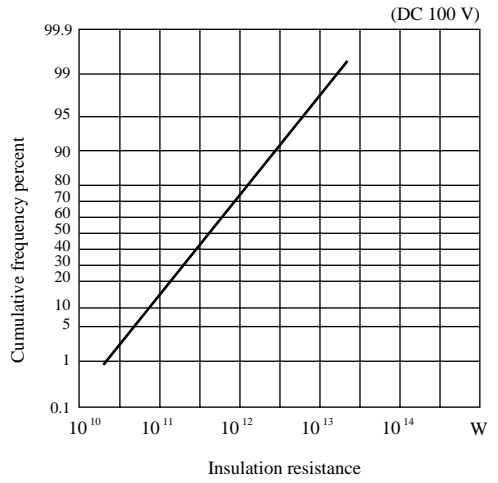

(5) Electrostatic capacitance

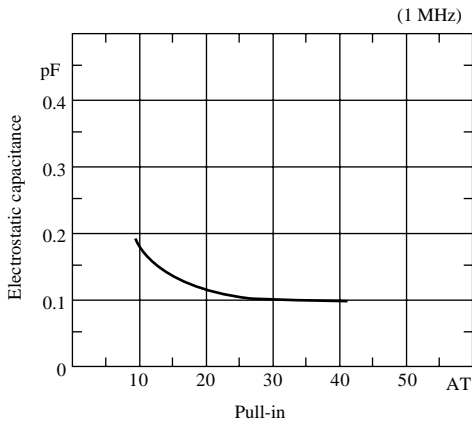

**OPERATING CHARACTERISTICS**

Parameter	Rated Value			Unit
	Min.	Typ.	Max.	
Operate Time	—	—	0.3	ms
Bounce Time	—	—	0.3	ms
Release Time	—	—	0.05	ms
Resonant Frequency	7000	7500	8000	Hz
Maximum Operating Frequency	—	—	500	Hz

(1) Operate time

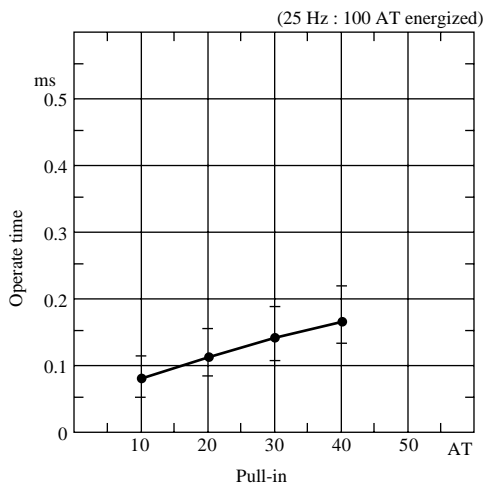

(2) Bounce time

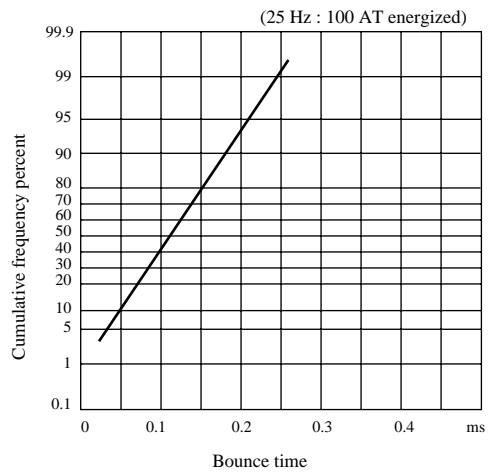

(3) Release time

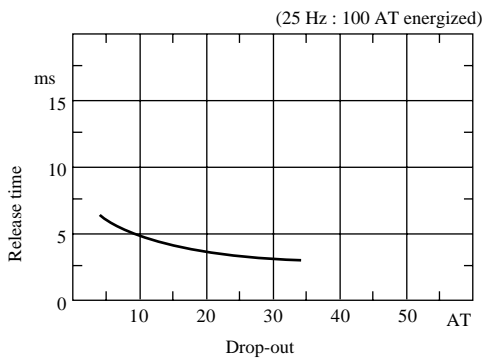

(4) Resonant frequency

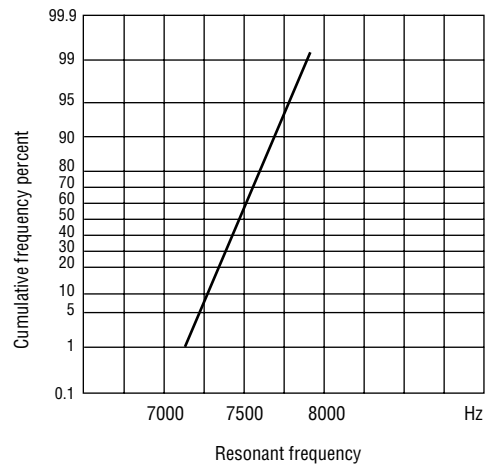

**MECHANICAL CHARACTERISTICS**

(1) Lead tensile test (static load)

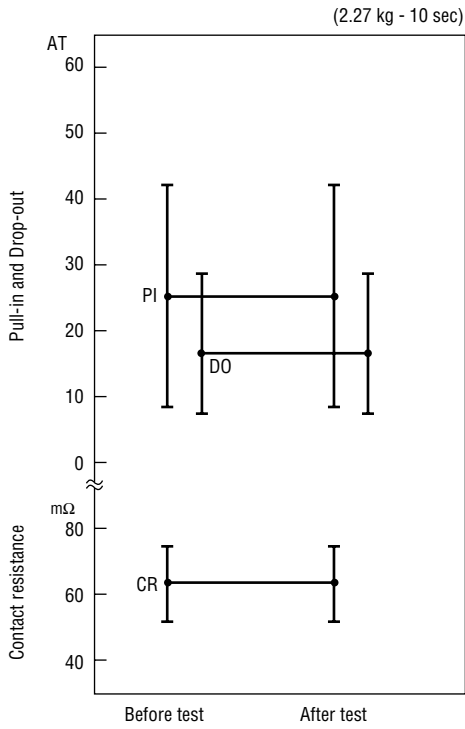

(2) Lead tensile strength

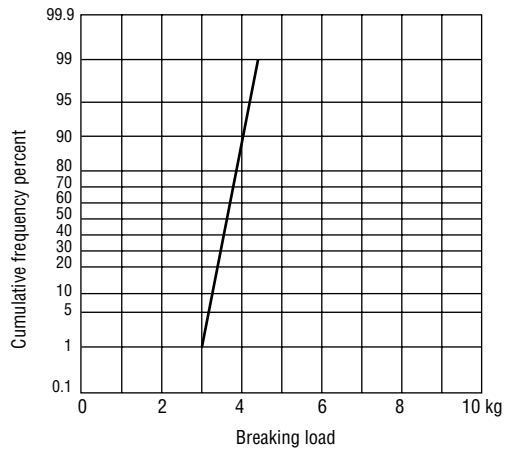

3

**ENVIRONMENTAL CHARACTERISTICS**

(1) Temperature characteristics

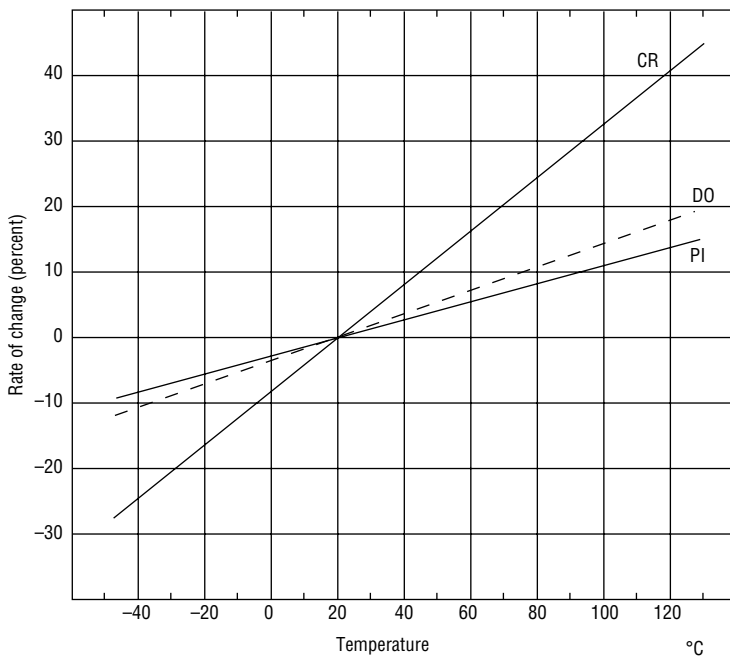

(2) Temperature cycle

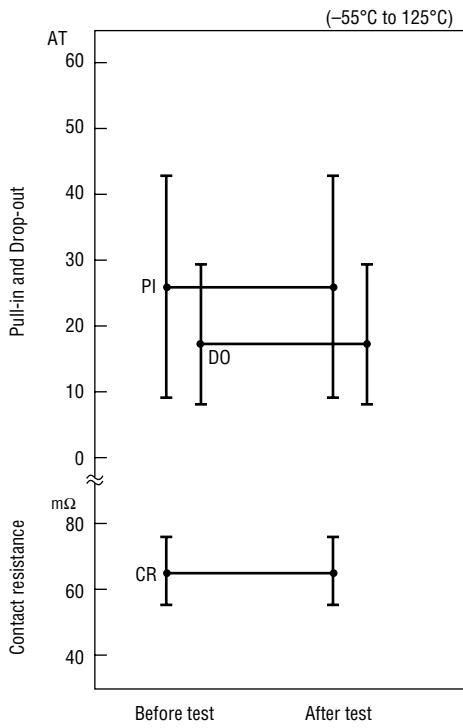

(3) Temperature and humidity cycle

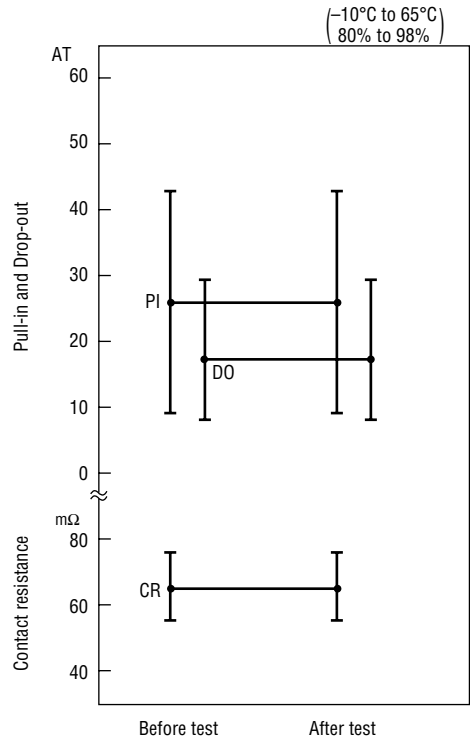

(4) High temperature storage test

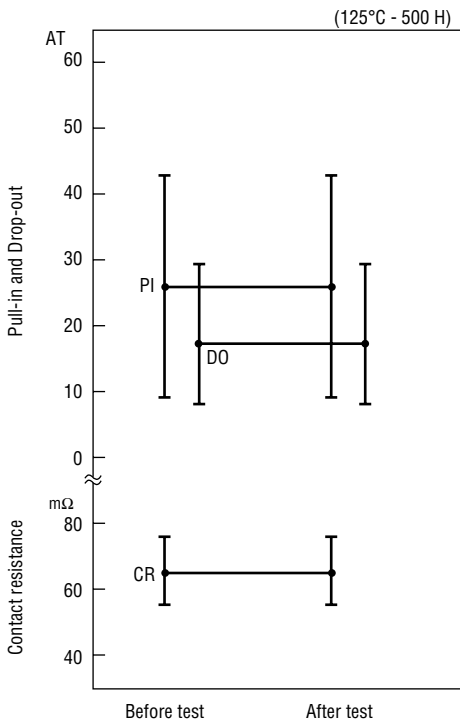

(5) Low temperature storage test

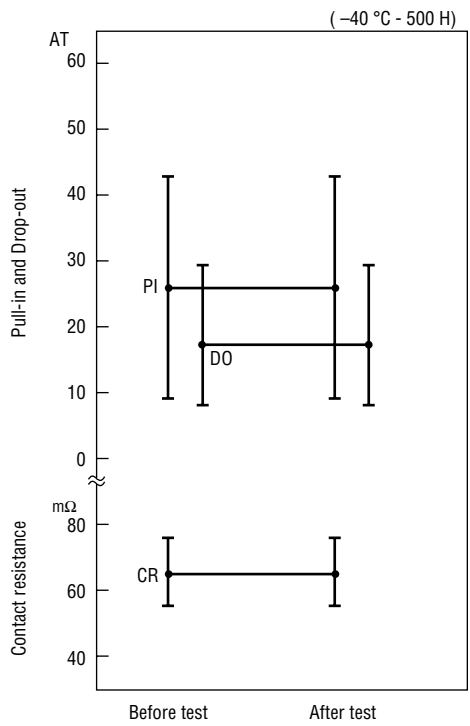

(6) Shock test

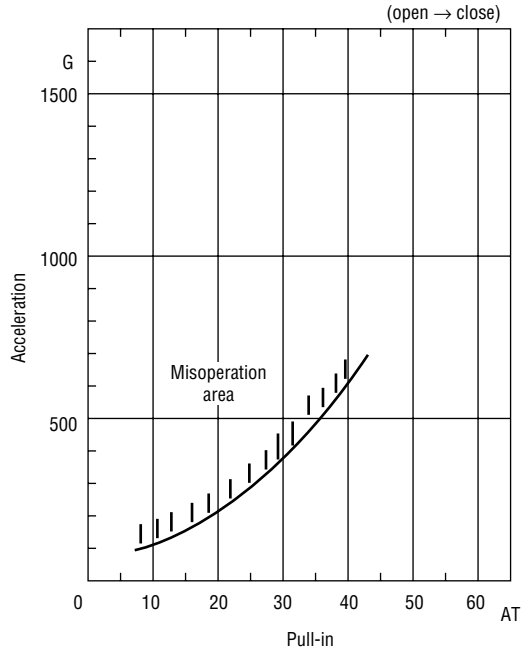
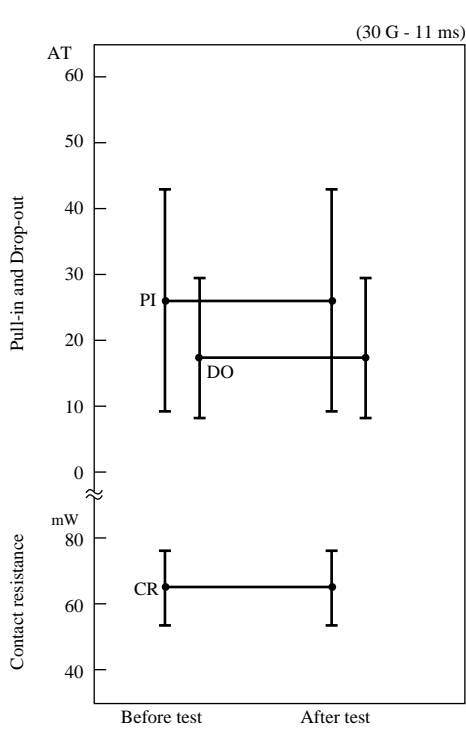

3

(7) Vibration test

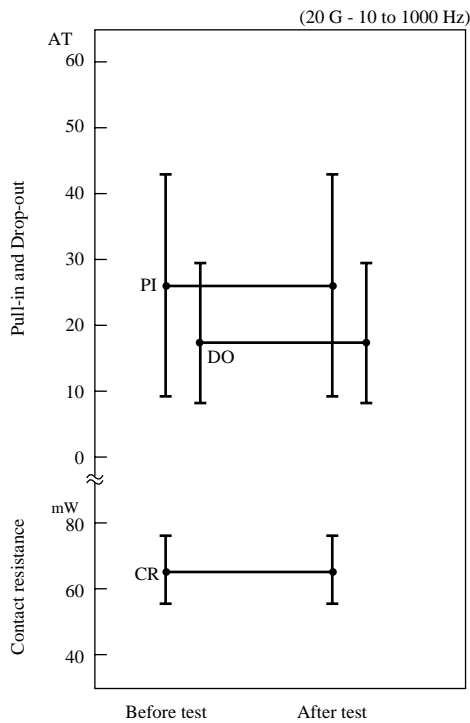



**LIFE EXPECTANCY DATA: ORD211**

Load conditions

Voltage : 5 VDC  
 Current : 100  $\mu$ A, 1 mA, 5 mA  
 Load : Resistive load

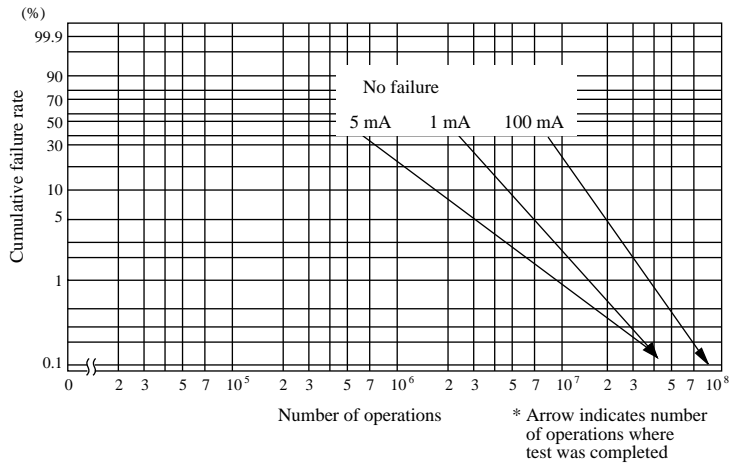

Load conditions

Voltage : 12 VDC  
 Current : 5 mA, 10 mA, 100 mA  
 Load : Resistive load

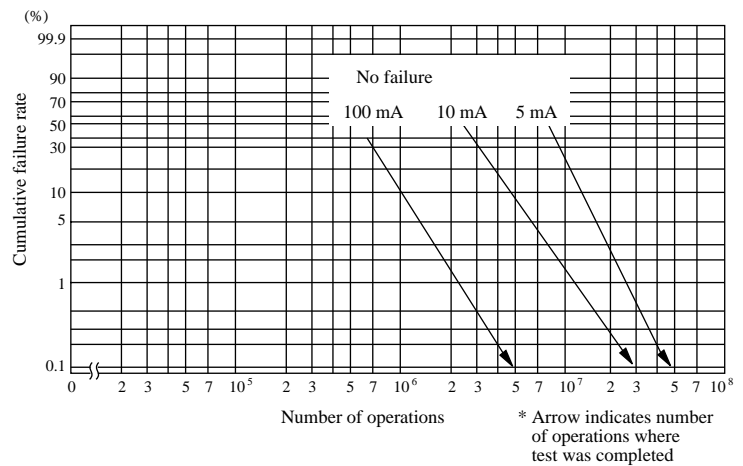

Load conditions

Voltage : 24 VDC  
 Current : 1 mA, 10 mA, 50 mA  
 Load : Resistive load

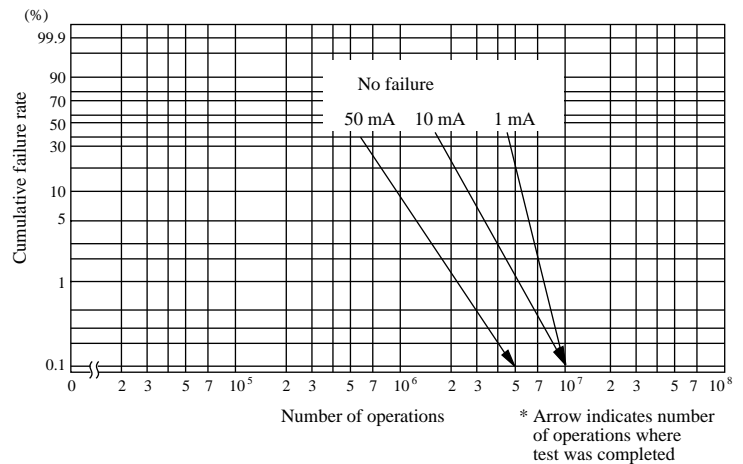

# REED SWITCH

## ORD213

**Extreme Ultraminiature (Low-level Load 24 V Max. for General Control)**

### GENERAL DESCRIPTION

The ORD213 is a small single-contact reed switch designed for general control of low-level loads less than 24 V. The reed contacts are sealed within the glass tube within inert gas to maintain contact reliability.

### Features

- (1) The reed contacts are hermetically sealed within a glass tube with inert gas and do not receive any influence from the external atmospheric environment.
- (2) High response speed
- (3) The operating system and electrical circuits are coaxially composed and the ORD213 is suited to the applications for high frequency transmission.
- (4) Compact and light weight
- (5) The superior corrosion resistance and wear resistance of the contacts assure stable switching operation and long life.
- (6) With a permanent magnet installed, the reed switch economically and easily becomes a proximity switch.

### External Dimensions (Unit:mm)

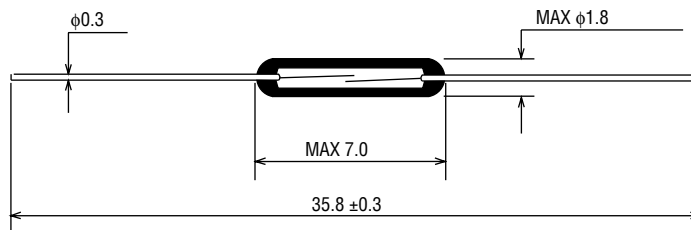

### APPLICATIONS OF REED SWITCHES

1. Automotive electronic devices
2. Control equipment
3. Communication equipment
4. Measurement equipment
5. Household appliances

**ELECTRICAL CHARACTERISTICS**

Parameter	Symbol	Condition	Rated Value			Unit
			Min.	Typ.	Max.	
Pull-in Value	PI	—	10	—	40	AT
Drop-out Value	DO	—	5	—	—	AT
Contact Resistance	CR	—	—	—	200	mΩ
Breakdown Voltage	—	—	150	—	—	VDC
Insulation Resistance	—	—	10 <sup>9</sup>	—	—	Ω
Electrostatic Capacitance	—	—	—	—	0.4	pF
Contact Rating	—	—	—	—	1.0	VA
Maximum Switching Voltage	—	—	—	—	24 <sup>DC</sup> <sub>AC</sub>	V
Maximum Switching Current	—	—	—	—	0.1	A
Maximum Carry Current	—	—	—	—	0.3	A

(1) Drop-out vs. Pull-in

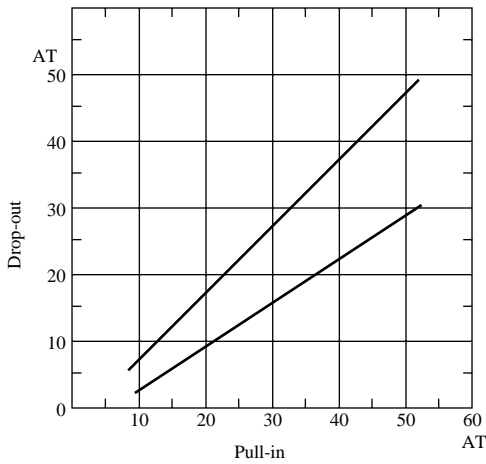

(2) Contact resistance



(3) Breakdown voltage

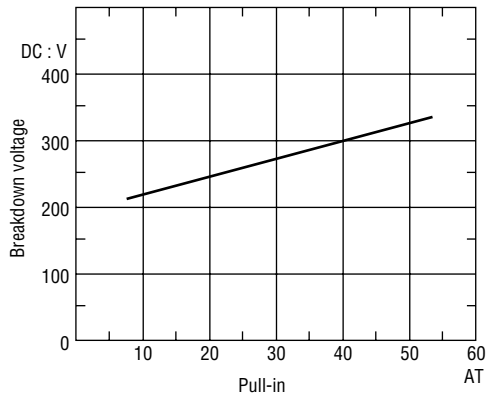

(4) Insulation resistance

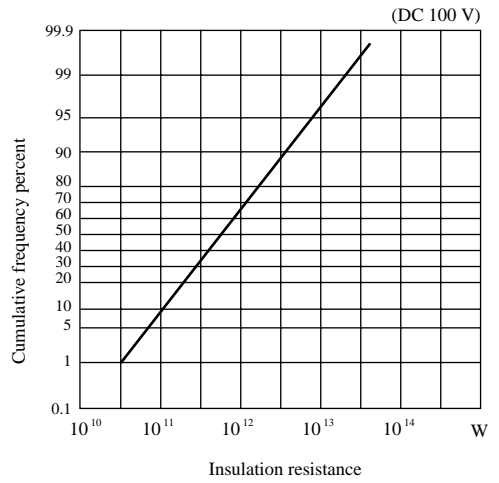

(5) Electrostatic capacitance

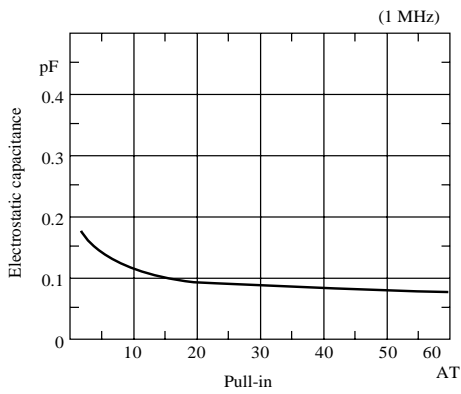

**OPERATING CHARACTERISTICS**

Parameter	Rated Value			Unit
	Min.	Typ.	Max.	
Operate Time	—	—	0.3	ms
Bounce Time	—	—	0.3	ms
Release Time	—	—	0.05	ms
Resonant Frequency	9000	11000	13000	Hz
Maximum Operating Frequency	—	—	500	Hz

(1) Operate time

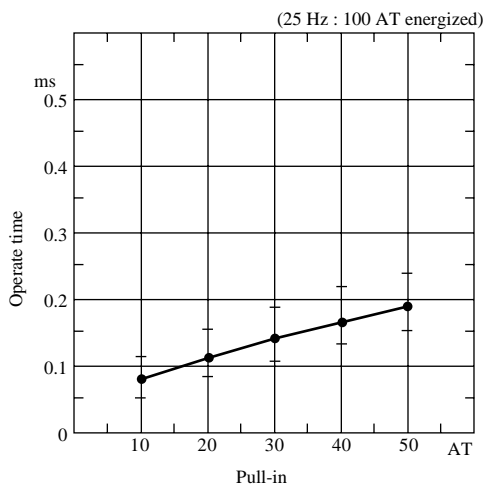

(2) Bounce time

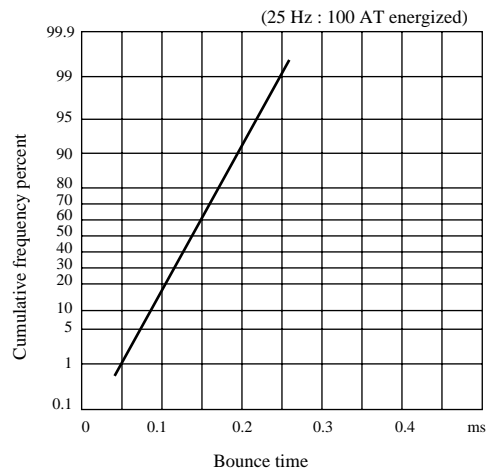

(3) Release time

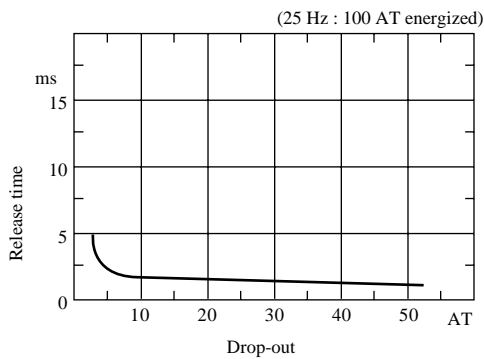

(4) Resonant frequency

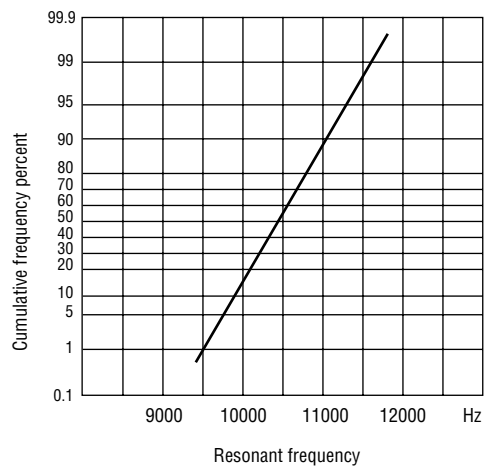

**MECHANICAL CHARACTERISTICS**

(1) Lead tensile test (static load)

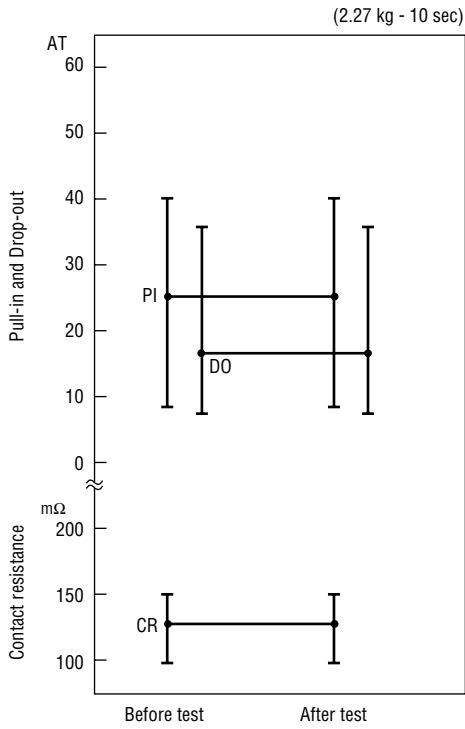

(2) Lead tensile strength

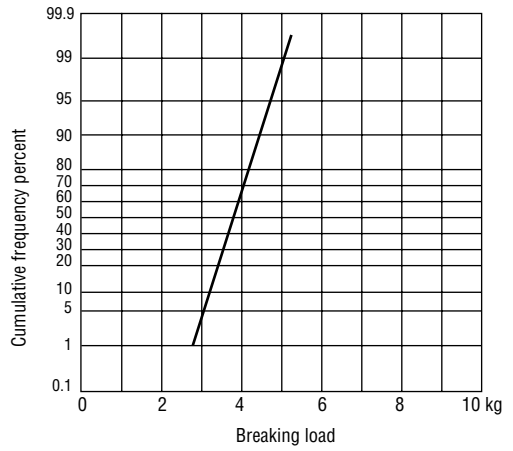

**ENVIRONMENTAL CHARACTERISTICS**

(1) Temperature characteristics

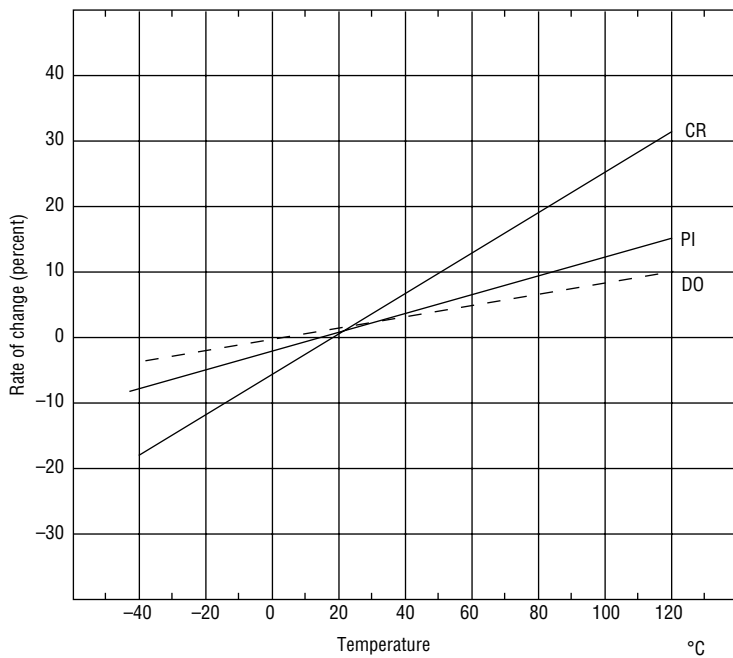

(2) Temperature cycle

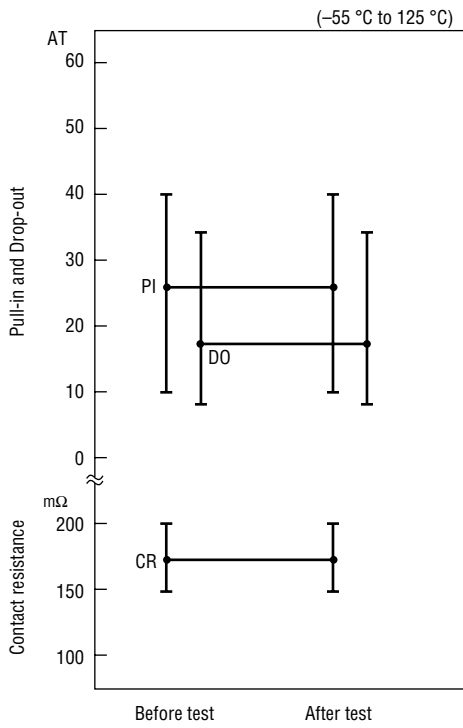

(3) Temperature and humidity cycle

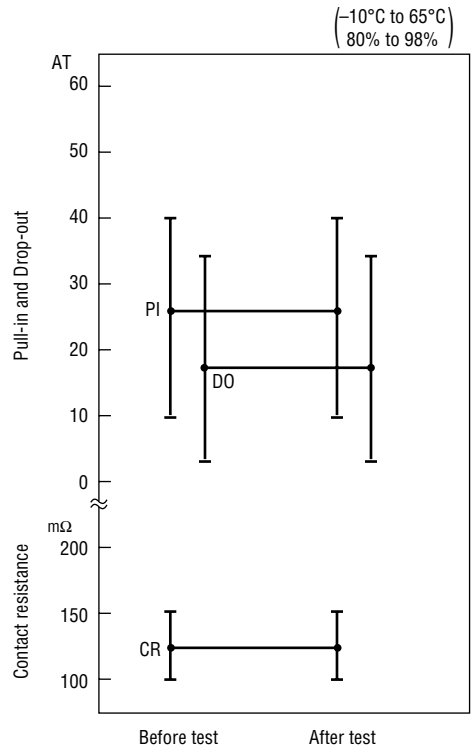

(4) High temperature storage test

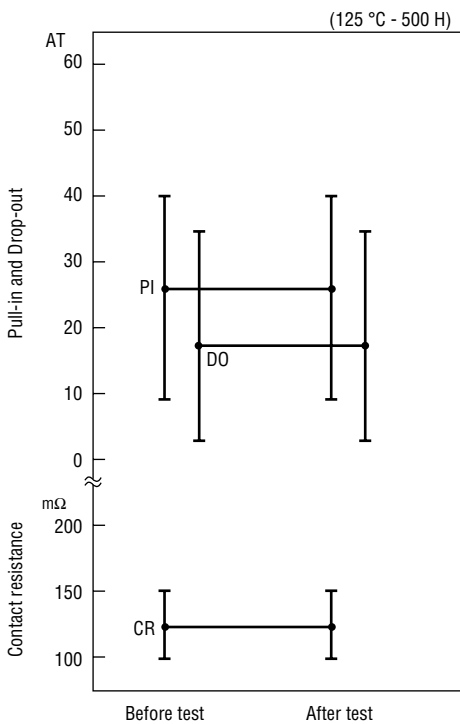

(5) Low temperature storage test

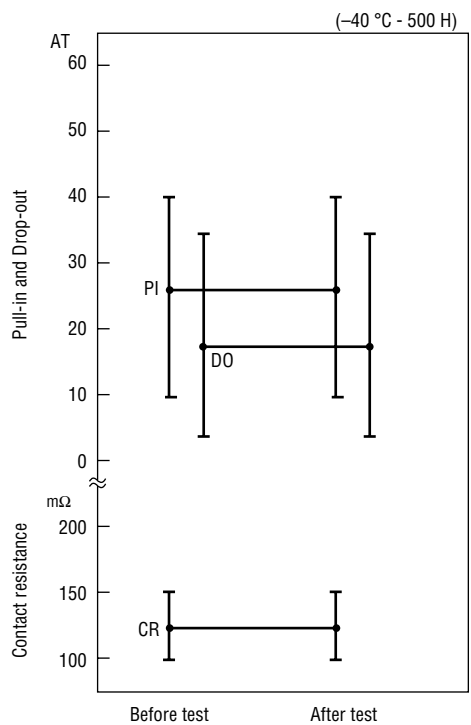

(6) Shock test

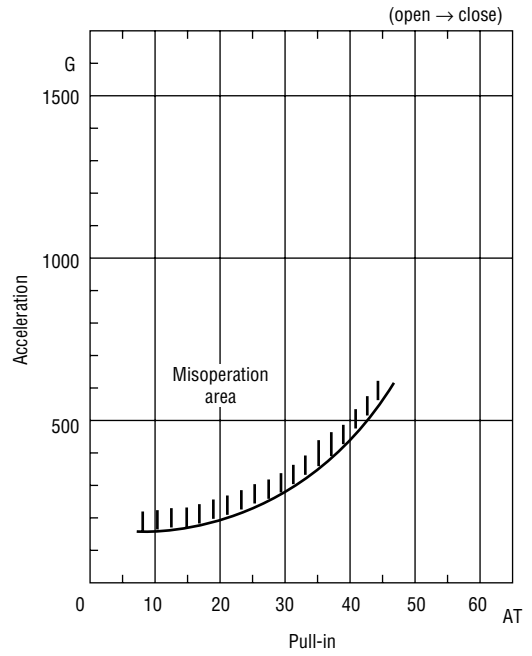
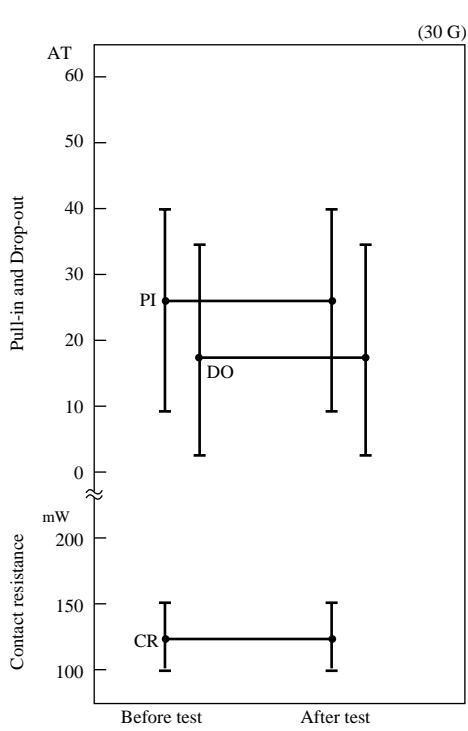

(7) Vibration test

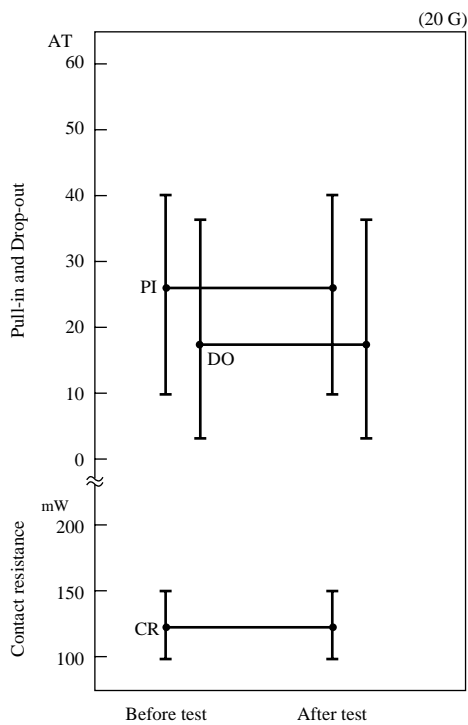



**LIFE EXPECTANCY DATA: ORD213**

Load conditions

Voltage : 5 VDC  
 Current : 100  $\mu$ A, 1 mA, 5 mA  
 Load : Resistive load

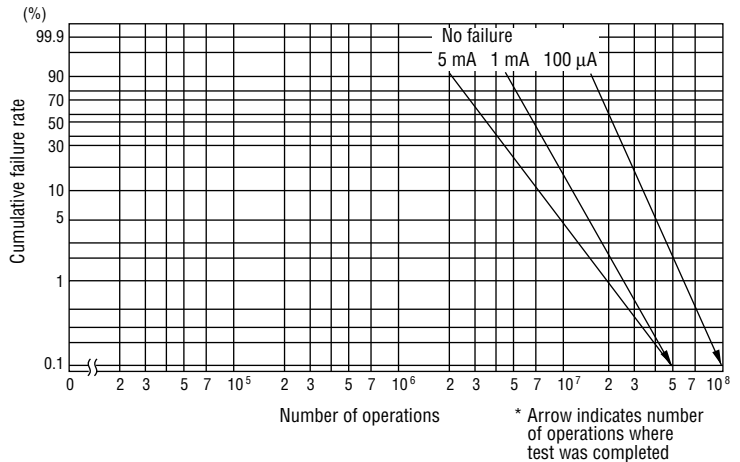

Load conditions

Voltage : 12 VDC  
 Current : 5 mA, 10 mA, 100 mA  
 Load : Resistive load

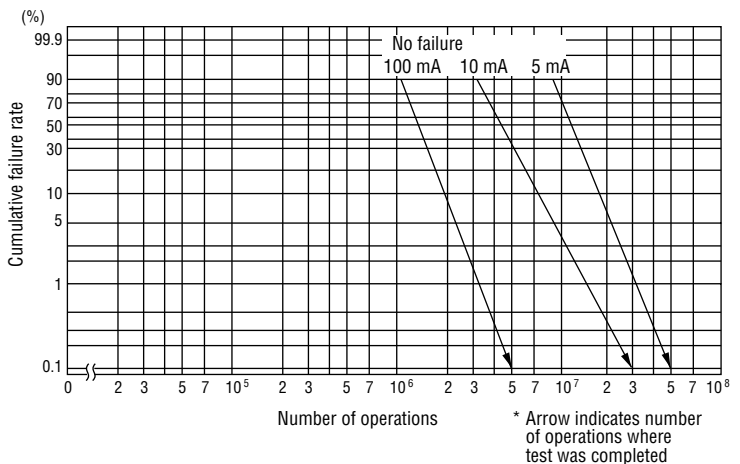

Load conditions

Voltage : 24 VDC  
 Current : 1 mA, 10 mA, 50 mA  
 Load : Resistive load

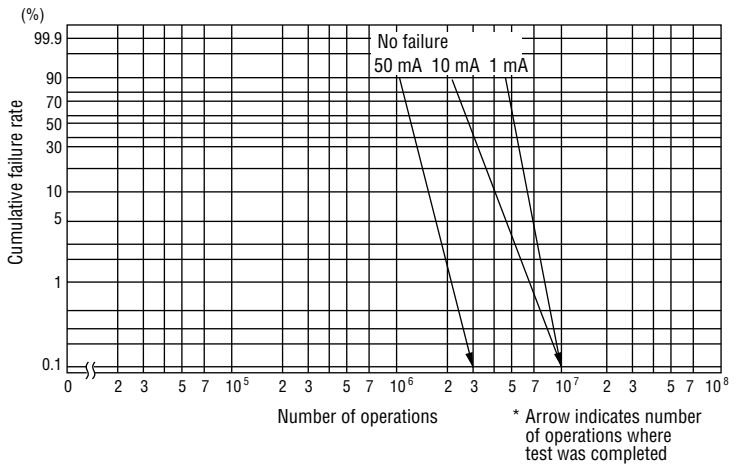

# REED SWITCH

## ORD219

General Purpose Miniature (Medium-level Load 100 V Max.)

### GENERAL DESCRIPTION

The ORD219 is a small single-contact reed switch designed for general control of medium-level loads less than 100 V. The contacts are sealed within the glass tube with inert gas to maintain contact reliability.

### Features

- (1) Reed contacts are hermetically sealed within a glass tube with inert gas and do not receive any influence from the external atmospheric environment.
- (2) Quick response
- (3) The structure comprises an operating system and electrical circuits coaxially. Reed switches are suited to applications in radio frequency.
- (4) Reed switches are compact and light weight.
- (5) Superior corrosion resistance and wear resistance of the contacts assures stable switching operation and long life.
- (6) With a permanent magnet installed, reed switches economically and easily become proximity switches.

### External Dimensions (Unit:mm)

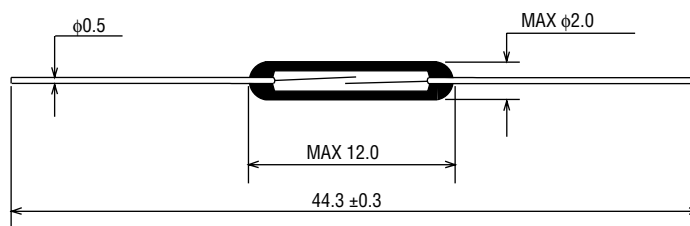

### APPLICATIONS OF REED SWITCHES

1. Automotive electronic devices
2. Control equipment
3. Communication equipment
4. Measurement equipment
5. Household appliances

**ELECTRICAL CHARACTERISTICS**

Parameter	Symbol	Condition	Rated Value			Unit
			Min.	Typ.	Max.	
Pull-in Value	PI	—	10	—	30	AT
Drop-out Value	DO	—	5	—	—	AT
Contact Resistance	CR	—	—	—	100	mΩ
Breakdown Voltage	—	—	200	—	—	VDC
Insulation Resistance	—	—	10 <sup>9</sup>	—	—	Ω
Electrostatic Capacitance	—	—	—	—	0.3	pF
Contact Rating	—	—	—	—	10	VA
Maximum Switching Voltage	—	—	—	—	100 <sup>DC</sup> <sub>AC</sub>	V
Maximum Switching Current	—	—	—	—	0.5	A
Maximum Carry Current	—	—	—	—	1.0	A

(1) Drop-out vs. Pull-in

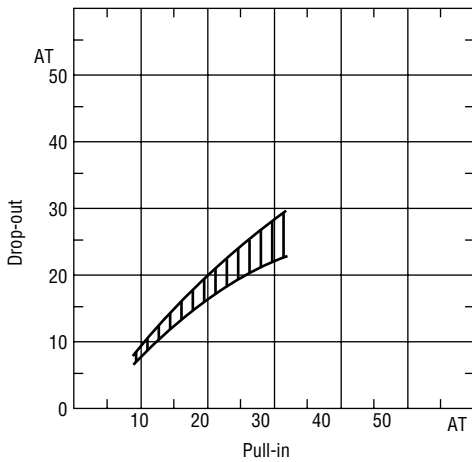

(2) Contact resistance

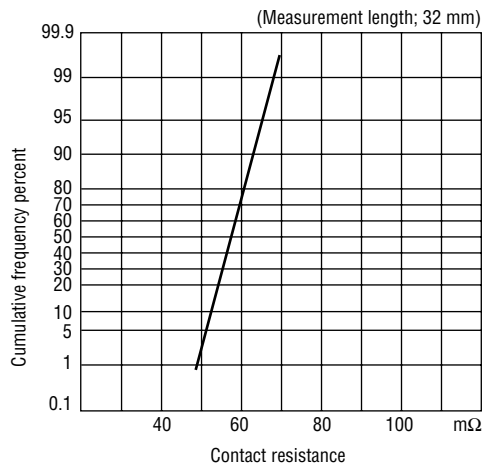

(3) Breakdown voltage

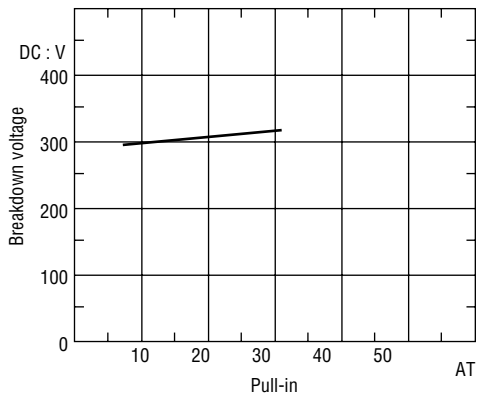

(4) Insulation resistance

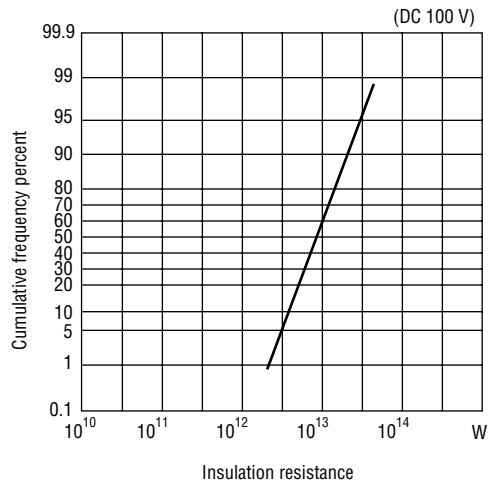

(5) Electrostatic capacitance

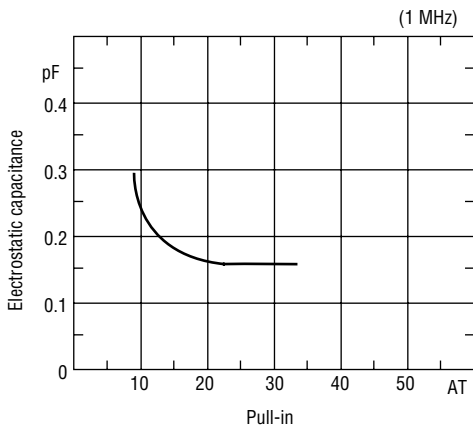

**OPERATING CHARACTERISTICS**

Parameter	Rated Value			Unit
	Min.	Typ.	Max.	
Operate Time	—	—	0.4	ms
Bounce Time	—	—	0.3	ms
Release Time	—	—	0.05	ms
Resonant Frequency	5500	5900	6300	Hz
Maximum Operating Frequency	—	—	500	Hz

(1) Operate time

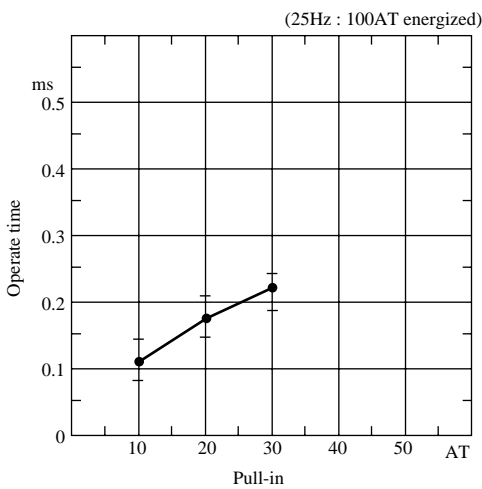

(2) Bounce time

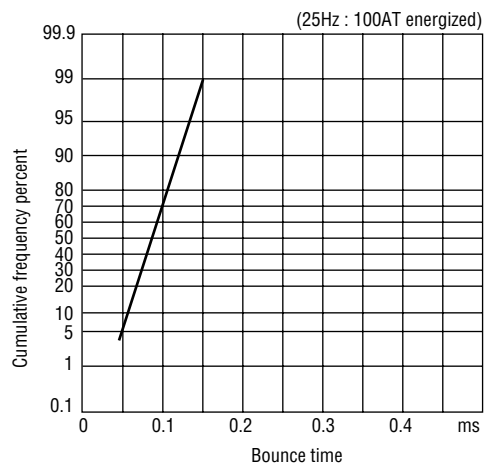

(3) Release time

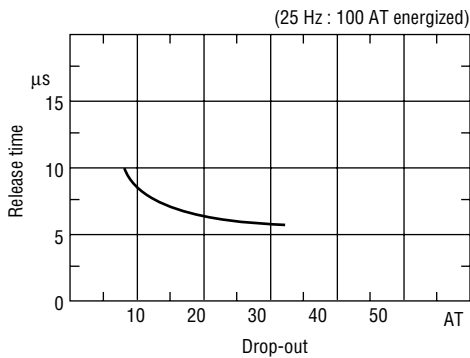

(4) Resonant frequency

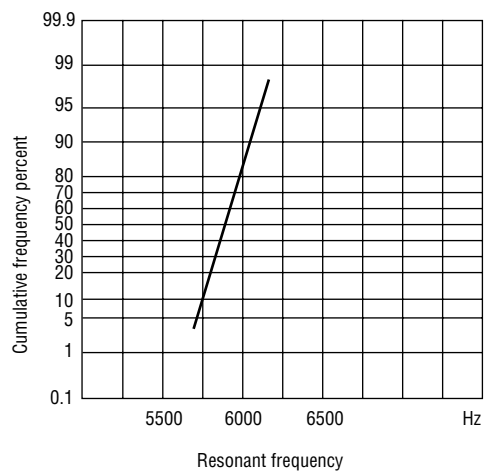

**MECHANICAL CHARACTERISTICS**

(1) Lead tensile test (static load)

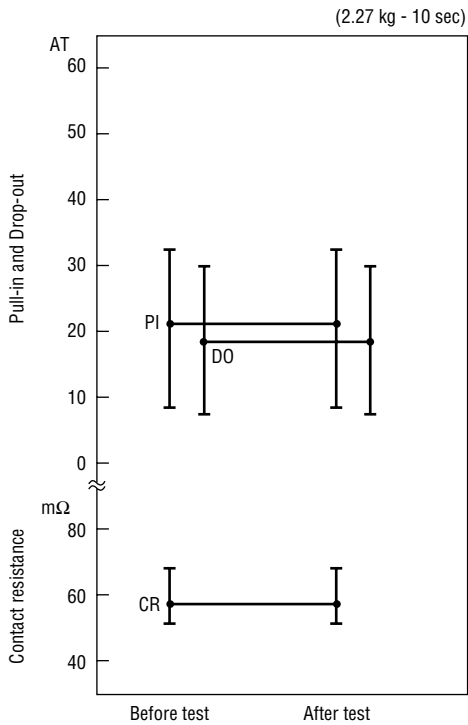

(2) Lead tensile strength

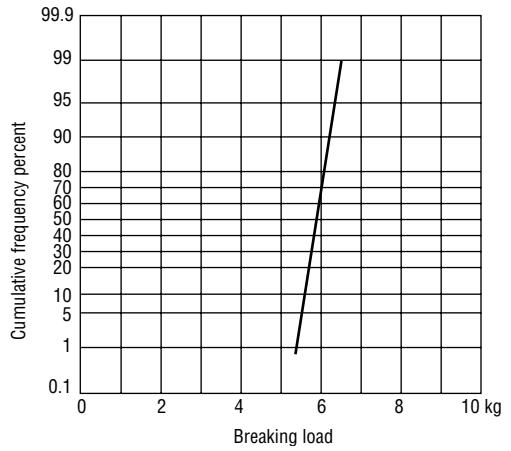

**ENVIRONMENTAL CHARACTERISTICS**

(1) Temperature characteristics

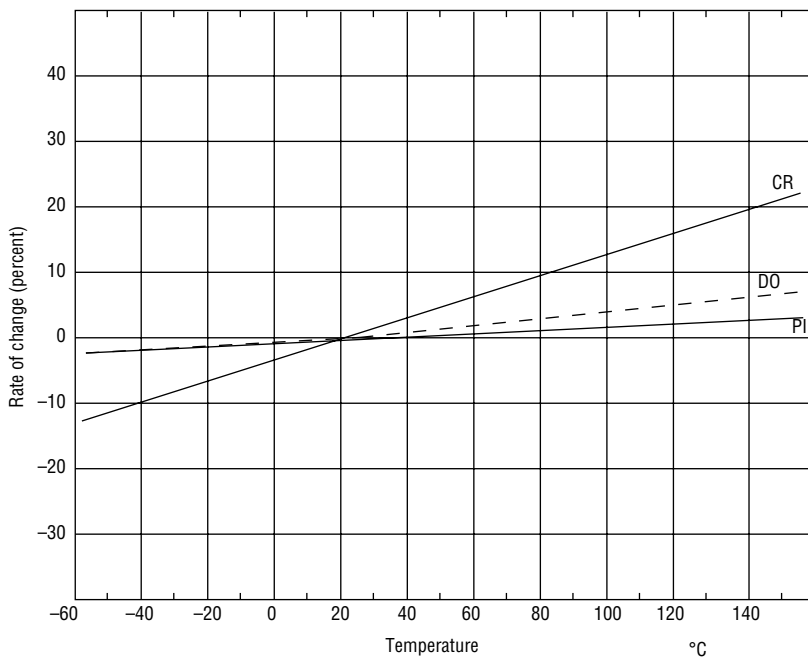

(2) Temperature cycle

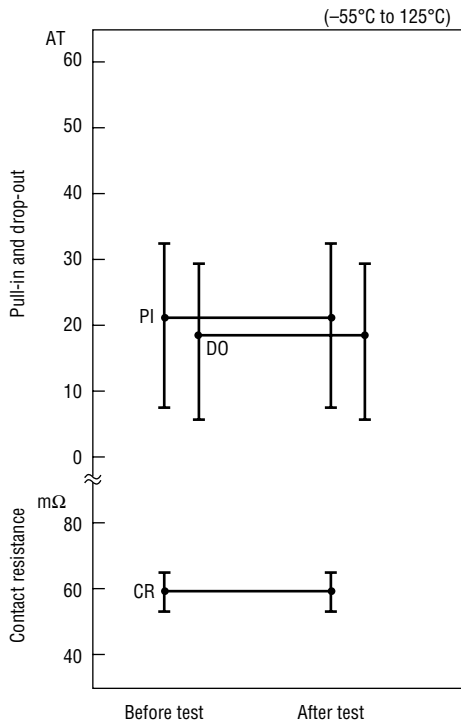

(3) Temperature and humidity cycle

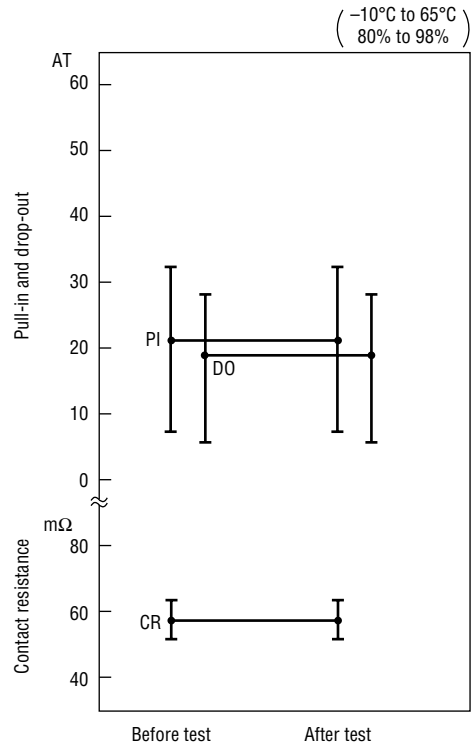

(4) High temperature storage test

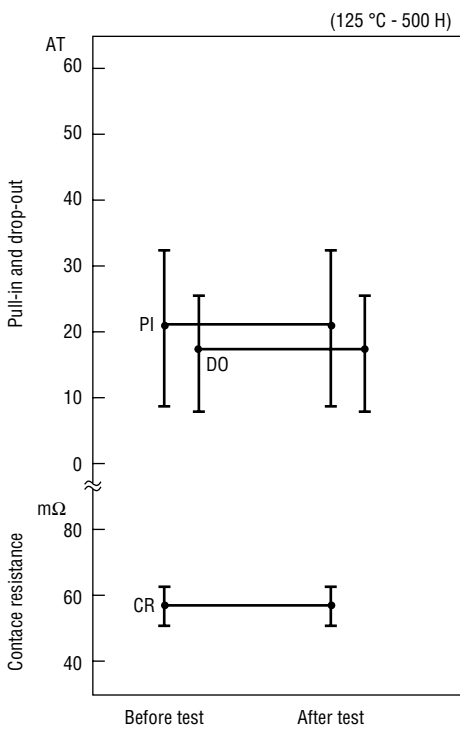

(5) Low temperature storage test

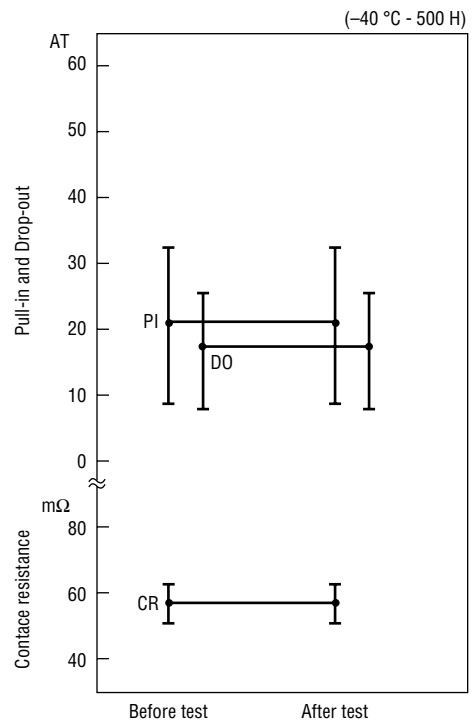

(6) Shock test

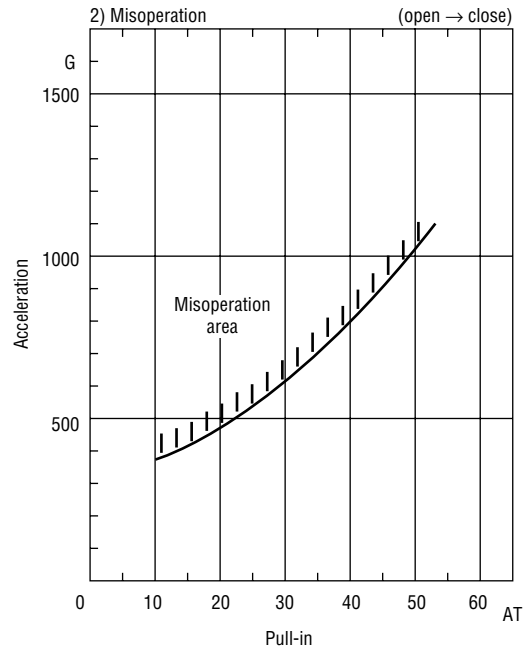
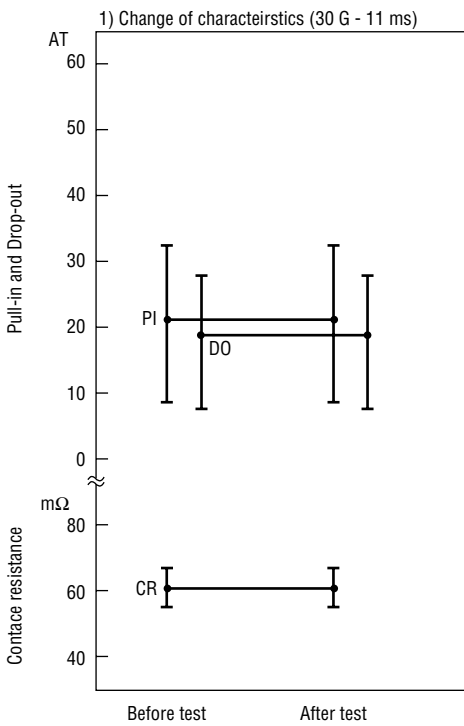

(7) Vibration test

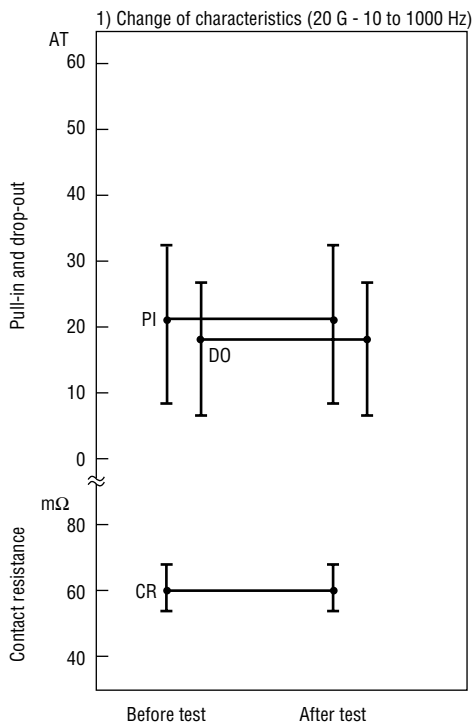



**LIFE EXPECTANCY DATA: ORD219**

Load conditions

Voltage : 5 VDC  
 Current : 100  $\mu$ A, 1 mA, 5 mA  
 Load : Resistive load

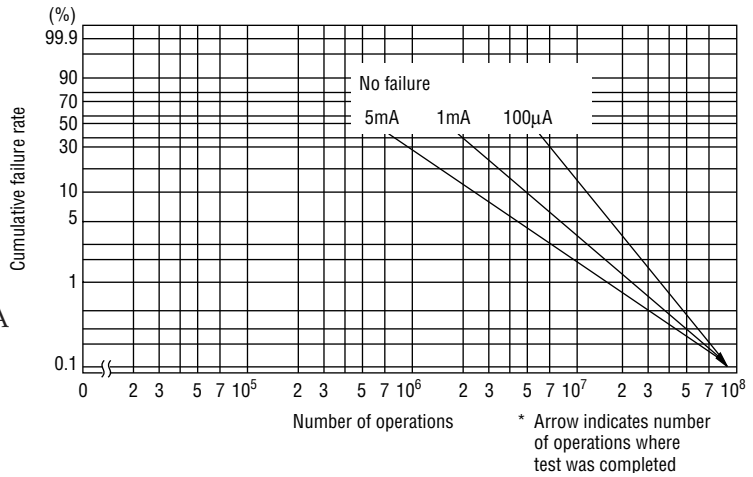

Load conditions

Voltage : 12 VDC  
 Current : 5 mA, 10 mA, 100 mA  
 Load : Resistive load

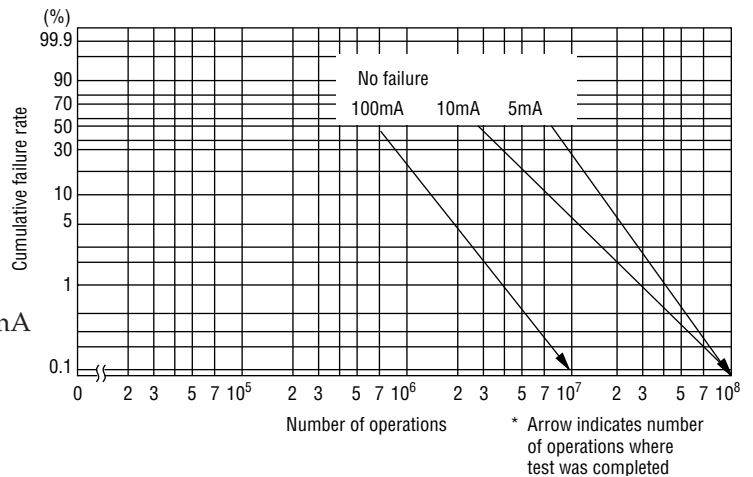

Load conditions

Voltage : 24 VDC  
 Current : 100 mA, 200 mA, 400 mA  
 Load : Resistive load

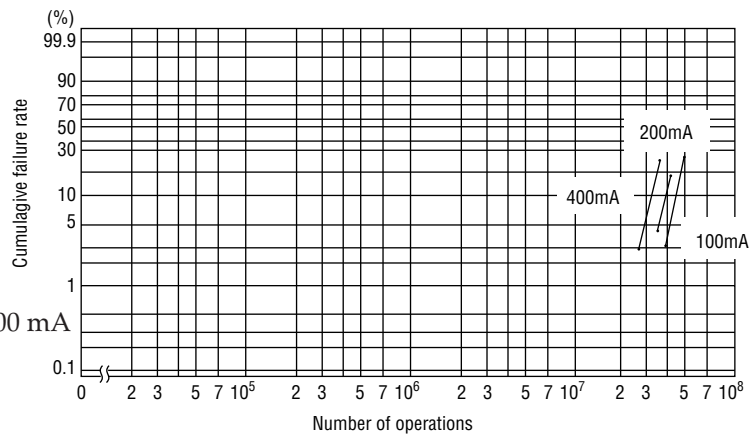

# REED SWITCH

## ORD221

**General Purpose Miniature Offset (Medium-level Load 100 V Max.)**

### GENERAL DESCRIPTION

The ORD221 is a small single-contact reed switch designed for general control of medium-level loads less than 100 V. The contacts are sealed within the glass tube with inert gas to maintain contact reliability.

### Features

- (1) Reed contacts are hermetically sealed within a glass tube with inert gas and do not receive any influence from the external atmospheric environment.
- (2) Quick response
- (3) The structure comprises an operating system and electrical circuits coaxially. Reed switches are suited to applications in radio frequency.
- (4) Reed switches are compact and light weight.
- (5) Superior corrosion resistance and wear resistance of the contacts assures stable switching operation and long life.
- (6) With a permanent magnet installed, reed switches economically and easily become proximity switches.

### External Dimensions (Unit:mm)

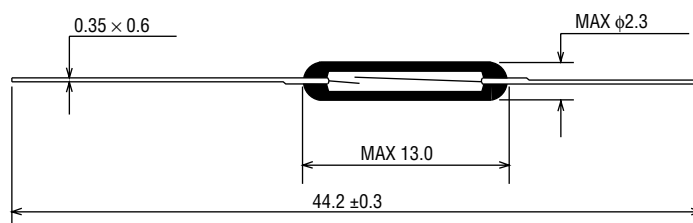

### APPLICATIONS OF REED SWITCHES

1. Automotive electronic devices
2. Control equipment
3. Communication equipment
4. Measurement equipment
5. Household appliances

**ELECTRICAL CHARACTERISTICS**

Parameter	Symbol	Condition	Rated Value			Unit
			Min.	Typ.	Max.	
Pull-in Value	PI	—	10	—	30	AT
Drop-out Value	DO	—	5	—	—	AT
Contact Resistance	CR	—	—	—	100	mΩ
Breakdown Voltage	—	PI>20	200	—	—	VDC
Breakdown Voltage	—	PI<20	150	—	—	VDC
Insulation Resistance	—	—	10 <sup>9</sup>	—	—	Ω
Electrostatic Capacitance	—	—	—	—	0.3	pF
Contact Rating	—	—	—	—	10	VA
Maximum Switching Voltage	—	—	—	—	100 <sup>DC</sup> <sub>AC</sub>	V
Maximum Switching Current	—	—	—	—	0.3	A
Maximum Carry Current	—	—	—	—	1.0	A

(1) Drop-out vs. Pull-in

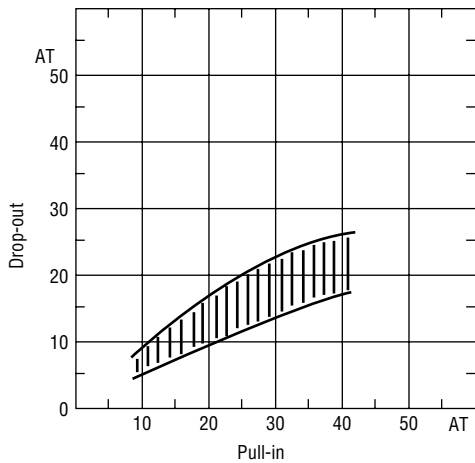

(2) Contact resistance

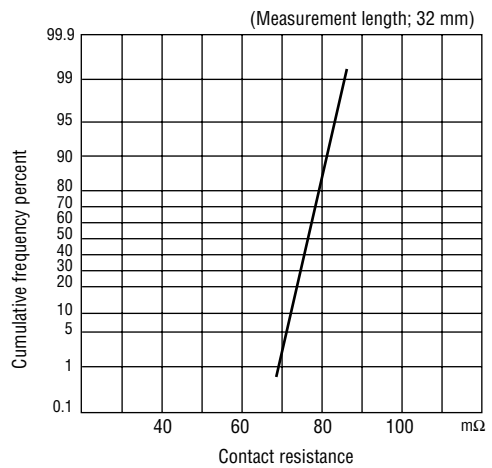

(3) Breakdown voltage

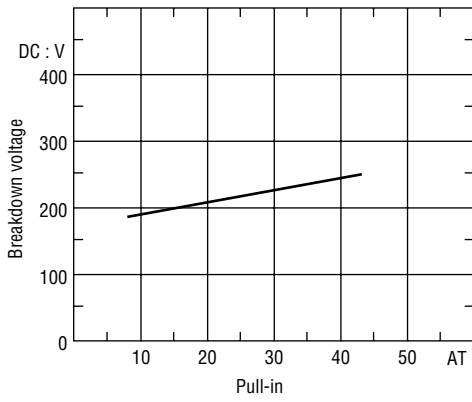

(4) Insulation resistance

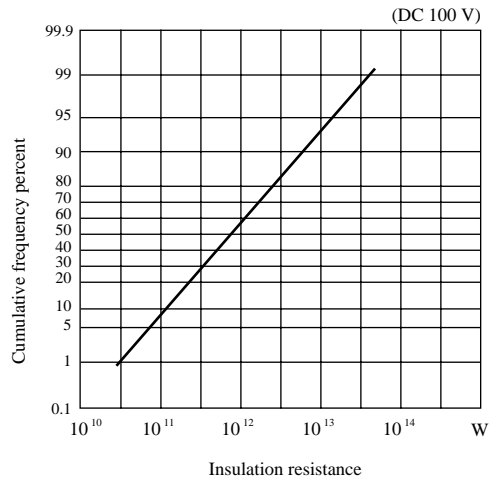

(5) Electrostatic capacitance

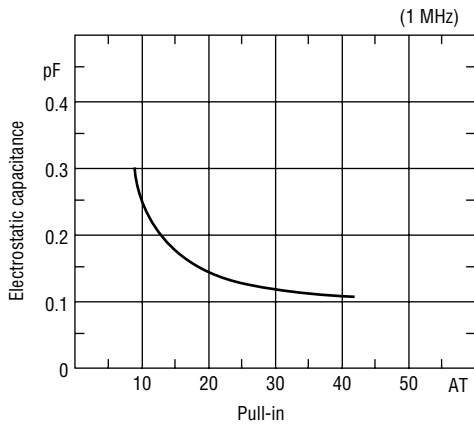

**OPERATING CHARACTERISTICS**

Parameter	Rated Value			Unit
	Min.	Typ.	Max.	
Operate Time	—	—	0.4	ms
Bounce Time	—	—	0.5	ms
Release Time	—	—	0.05	ms
Resonant Frequency	2500	2750	3000	Hz
Maximum Operating Frequency	—	—	500	Hz

(1) Operate time

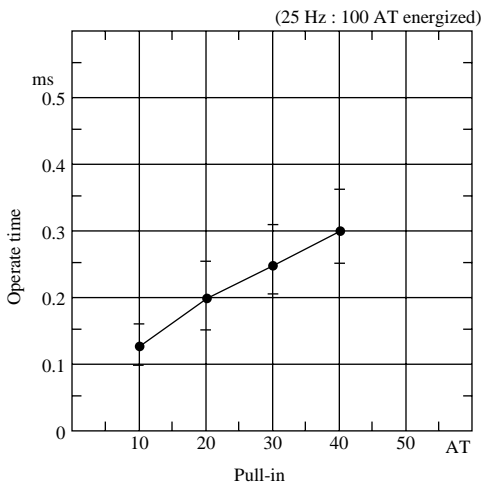

(2) Bounce time

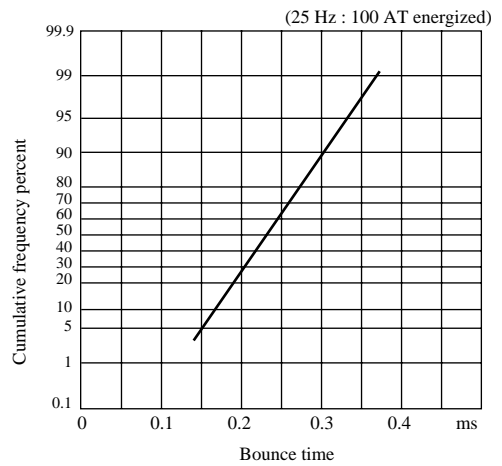

(3) Release time

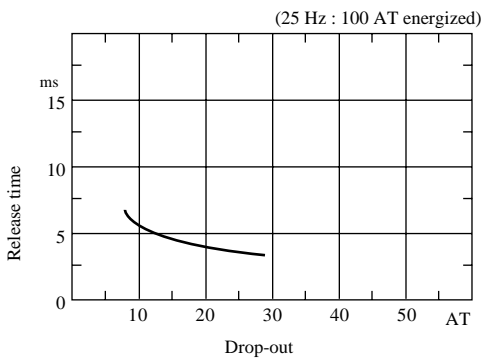

(4) Resonant frequency

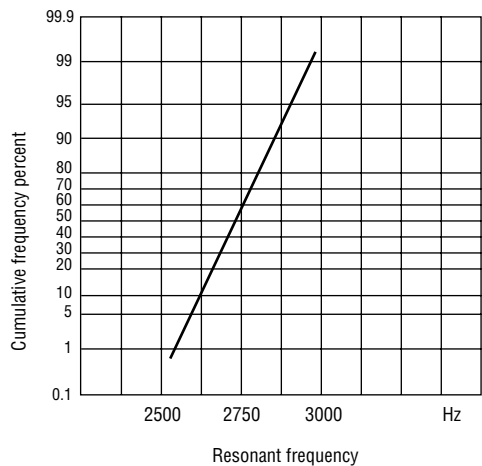

### MECHANICAL CHARACTERISTICS

(1) Lead tensile test (static load)

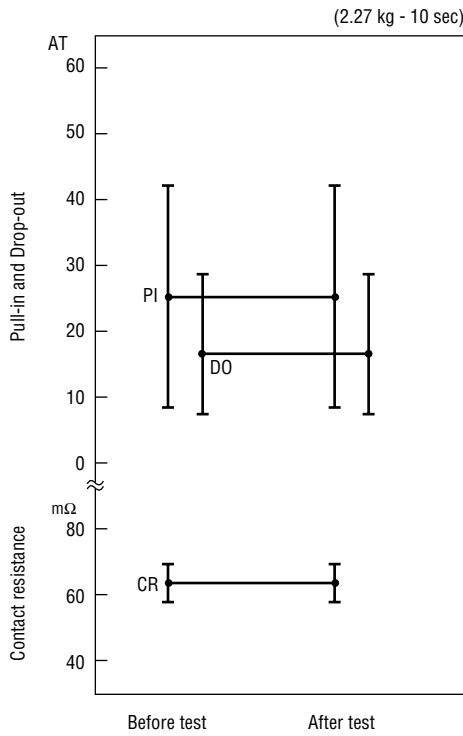

(2) Lead tensile strength

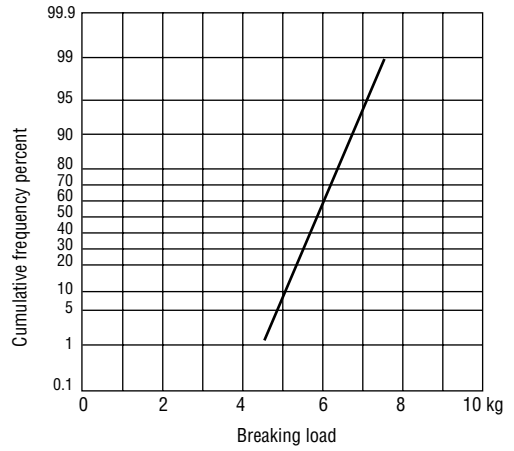

### ENVIRONMENTAL CHARACTERISTICS

(1) Temperature characteristics

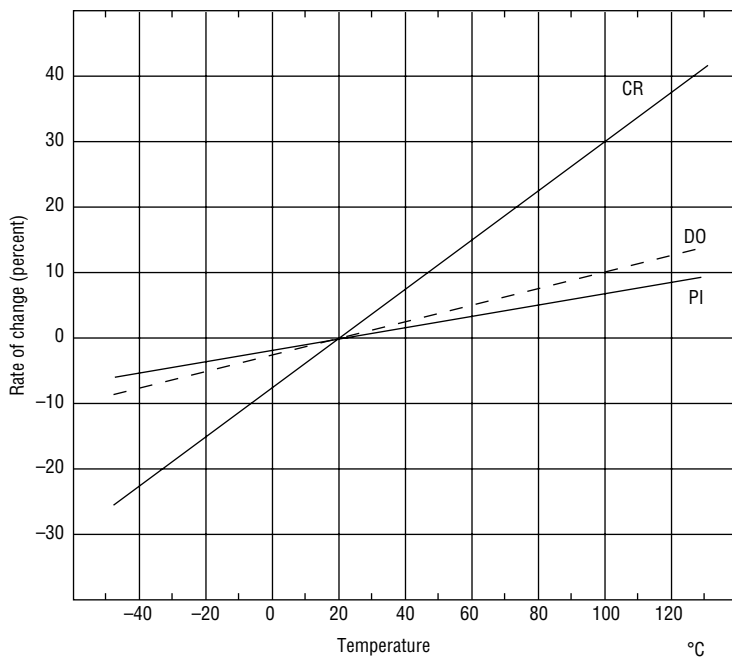

(2) Temperature cycle

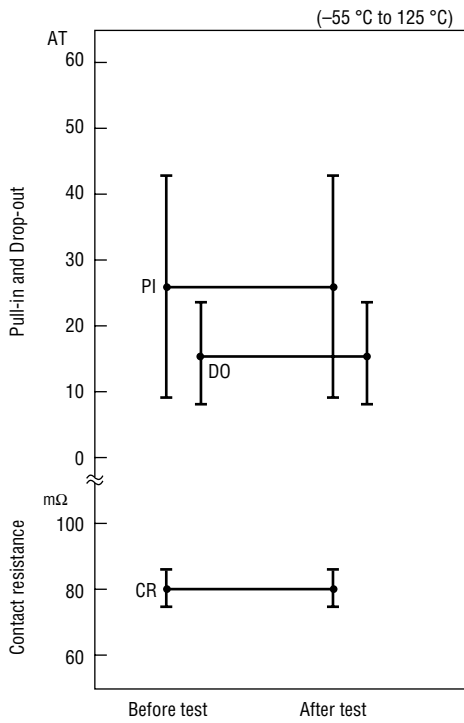

(3) Temperature and humidity cycle

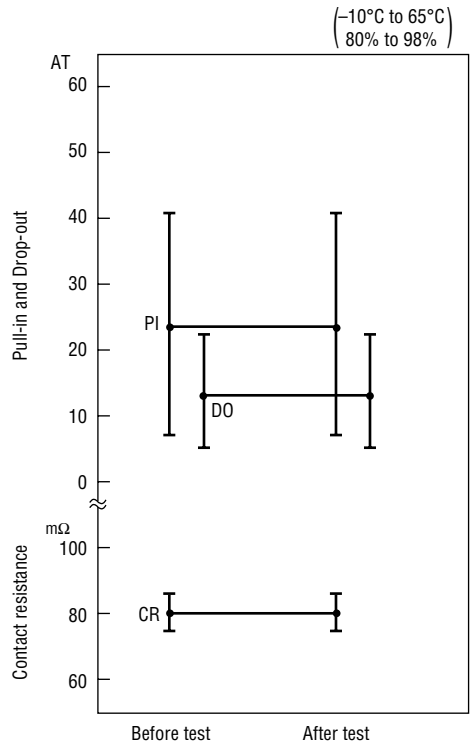

(4) High temperature storage test

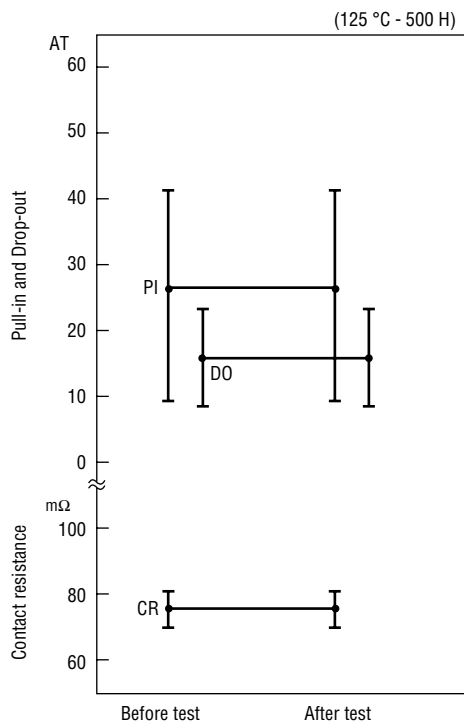

(5) Low temperature storage test

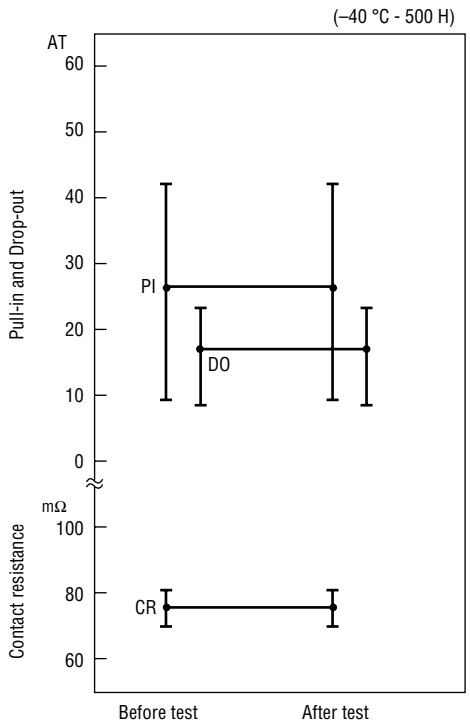

(6) Shock test

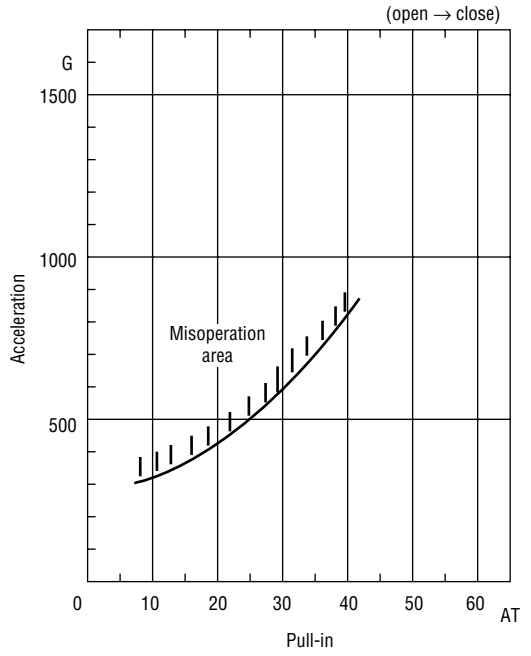
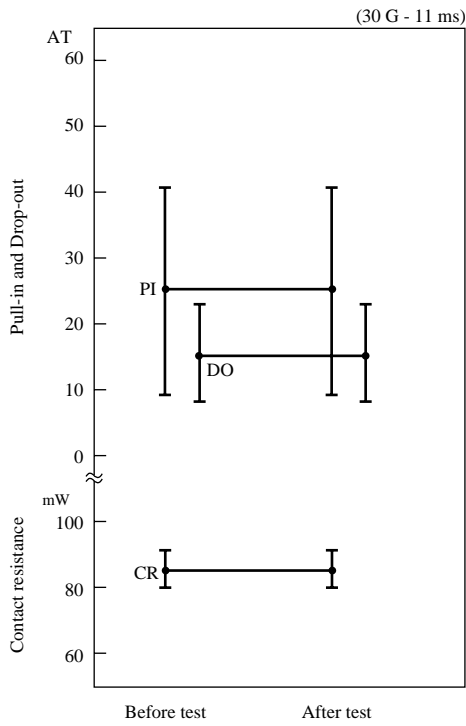

(7) Vibration test

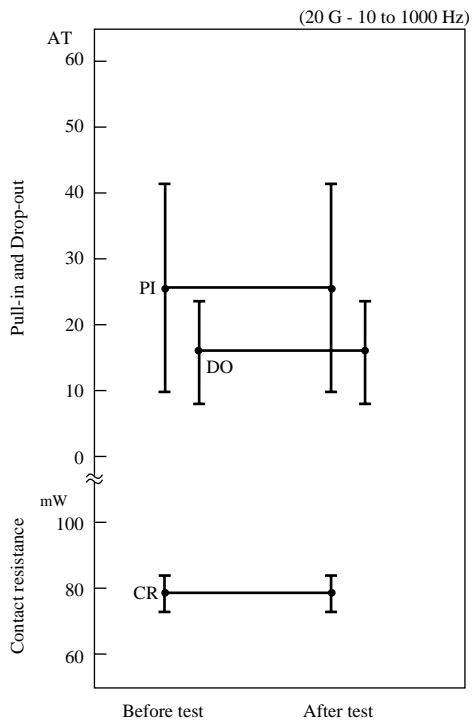



**LIFE EXPECTANCY DATA: ORD221**

Load conditions

Voltage : 5 VDC  
 Current : 100  $\mu$ A, 1 mA, 5 mA  
 Load : Resistive load

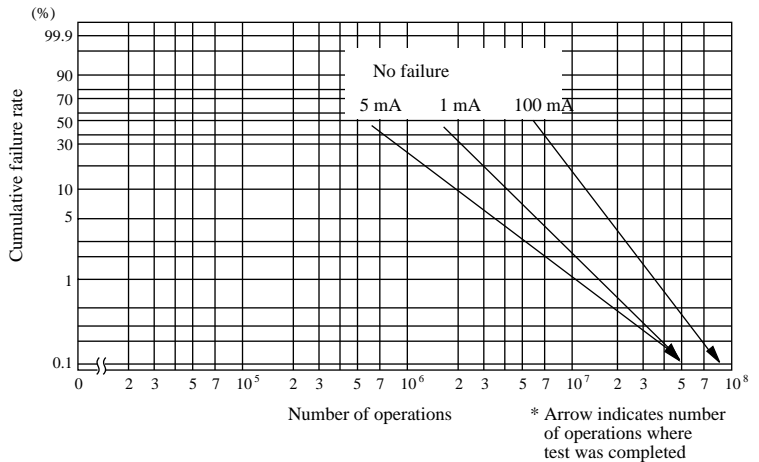

Load conditions

Voltage : 12 VDC  
 Current : 5 mA, 10 mA, 100 mA  
 Load : Resistive load

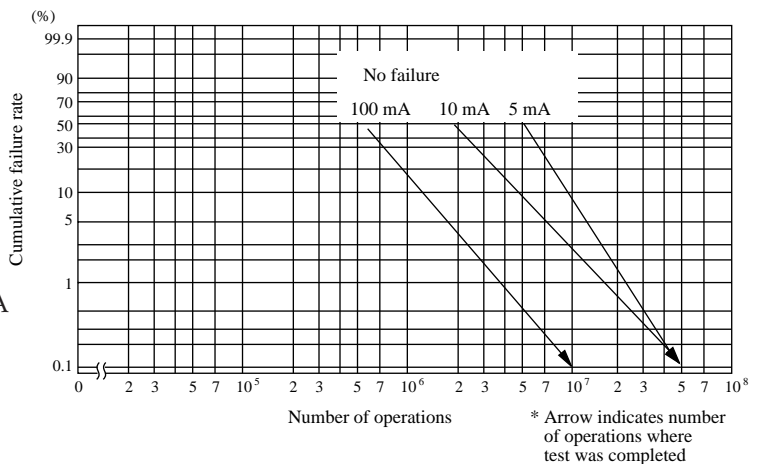

Load conditions

Voltage : 24 VDC  
 Current : 10 mA, 100 mA, 200 mA  
 Load : Resistive load

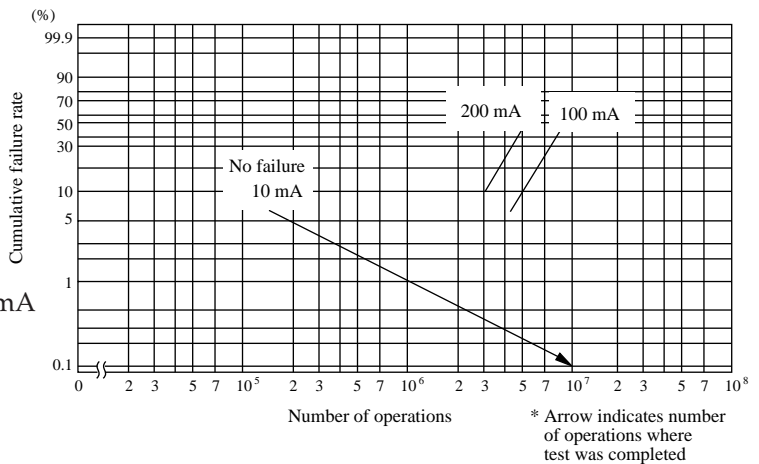

# REED SWITCH

## ORD228VL

General Purpose Miniature (Medium-level Load 100 V Max.)

### GENERAL DESCRIPTION

The ORD228VL is a small single-contact reed switch designed for general control of medium-level loads less than 100 V. The contacts are sealed within the glass tube with inert gas to maintain contact reliability.

### Features

- (1) Reed contacts are hermetically sealed within a glass tube with inert gas and do not receive any influence from the external atmospheric environment.
- (2) Quick response
- (3) The structure comprises an operating system and electrical circuits coaxially. Reed switches are suited to applications in radio frequency.
- (4) Reed switches are compact and light weight.
- (5) Superior corrosion resistance and wear resistance of the contacts assures stable switching operation and long life.
- (6) With a permanent magnet installed, reed switches economically and easily become proximity switches.

### External Dimensions (Unit:mm)

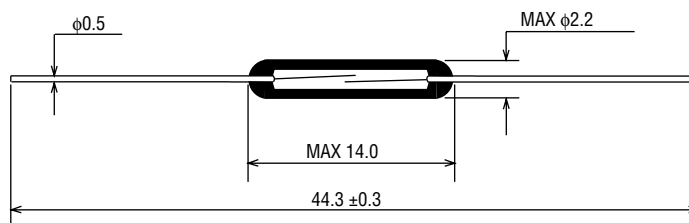

### APPLICATIONS OF REED SWITCHES

1. Automotive electronic devices
2. Control equipment
3. Communication equipment
4. Measurement equipment
5. Household appliances

**ELECTRICAL CHARACTERISTICS**

Parameter	Symbol	Condition	Rated Value			Unit
			Min.	Typ.	Max.	
Pull-in Value	PI	—	10	—	45	AT
Drop-out Value	DO	—	5	—	—	AT
Contact Resistance	CR	—	—	—	100	mΩ
Breakdown Voltage	—	PI>20	200	—	—	VDC
Breakdown Voltage	—	PI<20	150	—	—	VDC
Insulation Resistance	—	—	10 <sup>9</sup>	—	—	Ω
Electrostatic Capacitance	—	—	—	—	0.3	pF
Contact Rating	—	—	—	—	10	VA
Maximum Switching Voltage	—	—	—	—	100 <sup>DC</sup> <sub>AC</sub>	V
Maximum Switching Current	—	—	—	—	0.5	A
Maximum Carry Current	—	—	—	—	1.0	A

(1) Drop-out vs. Pull-in

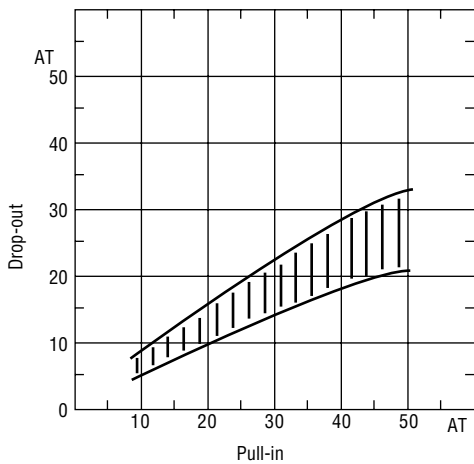

(2) Contact resistance

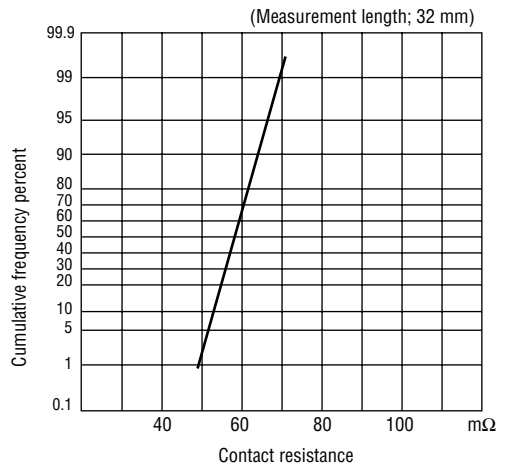

(3) Breakdown voltage

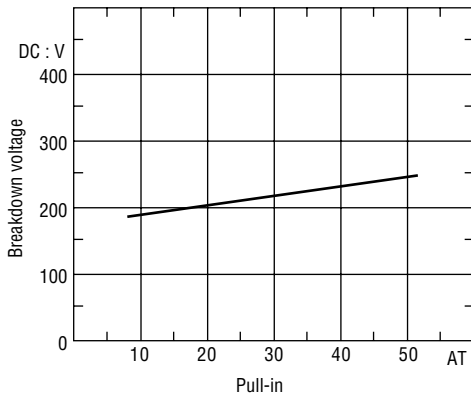

(4) Insulation resistance

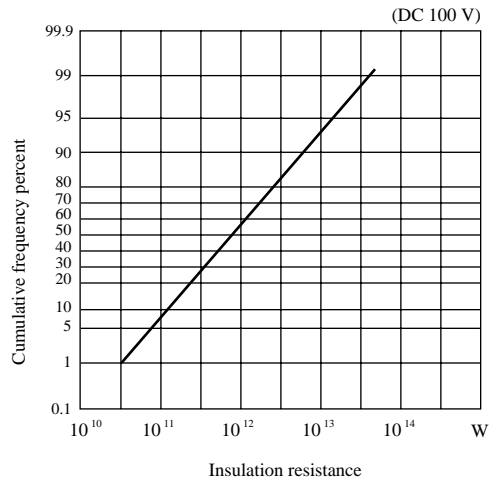

(5) Electrostatic capacitance

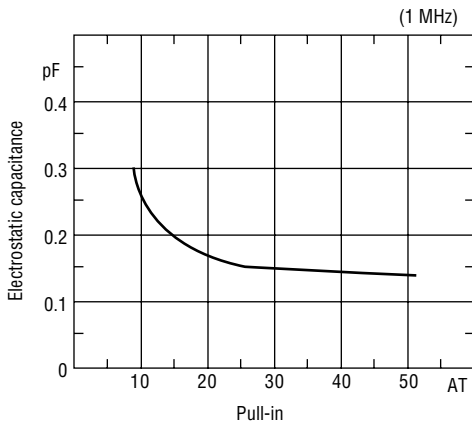

**OPERATING CHARACTERISTICS**

Parameter	Rated Value			Unit
	Min.	Typ.	Max.	
Operate Time	—	—	0.4	ms
Bounce Time	—	—	0.3	ms
Release Time	—	—	0.05	ms
Resonant Frequency	4600	5000	5400	Hz
Maximum Operating Frequency	—	—	500	Hz

(1) Operate time

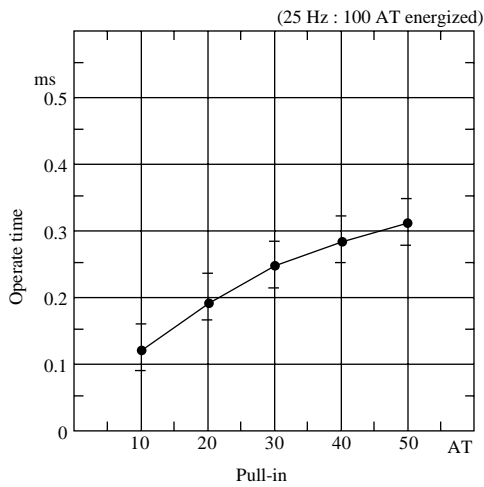

(2) Bounce time

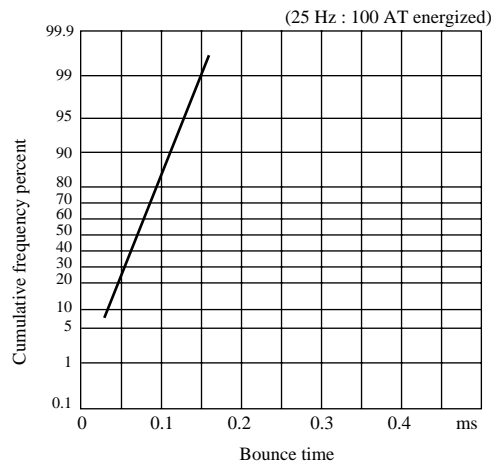

(3) Release time

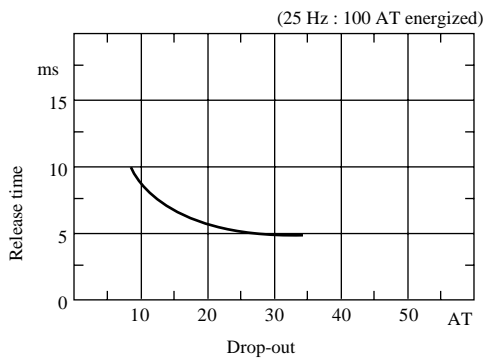

(4) Resonant frequency

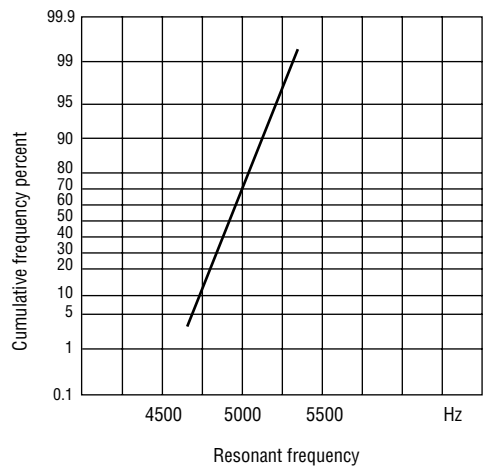

**MECHANICAL CHARACTERISTICS**

(1) Lead tensile test (static load)

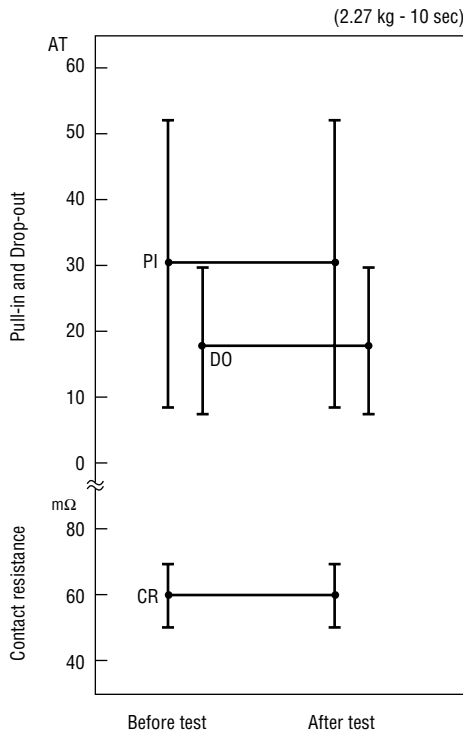

(2) Lead tensile strength

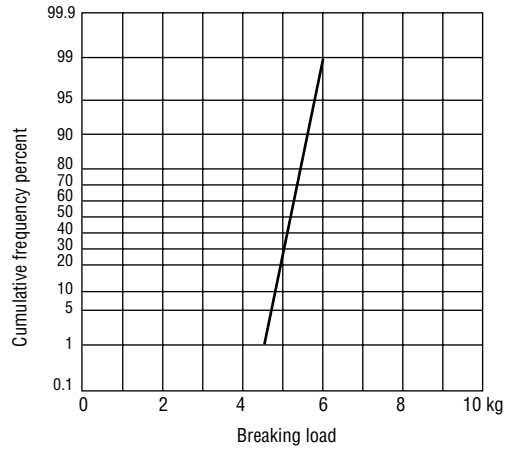

**ENVIRONMENTAL CHARACTERISTICS**

(1) Temperature characteristics

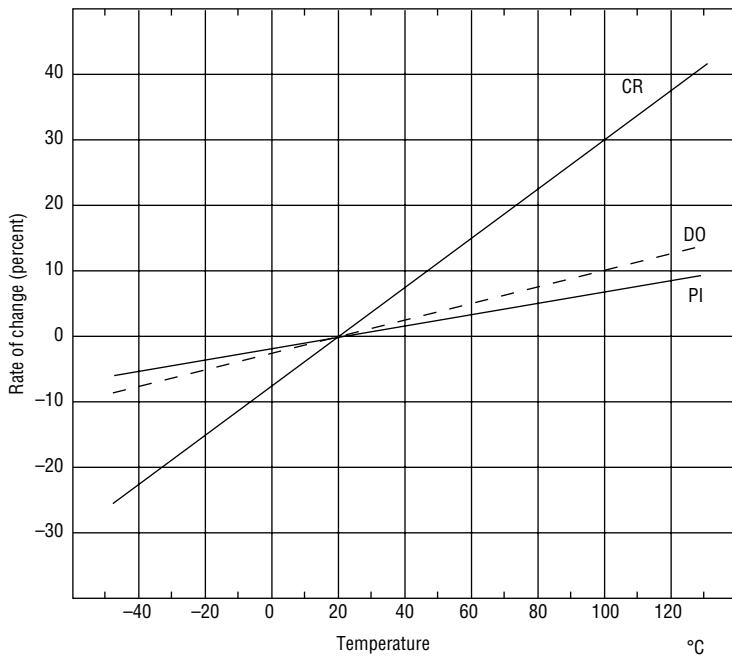

(2) Temperature cycle

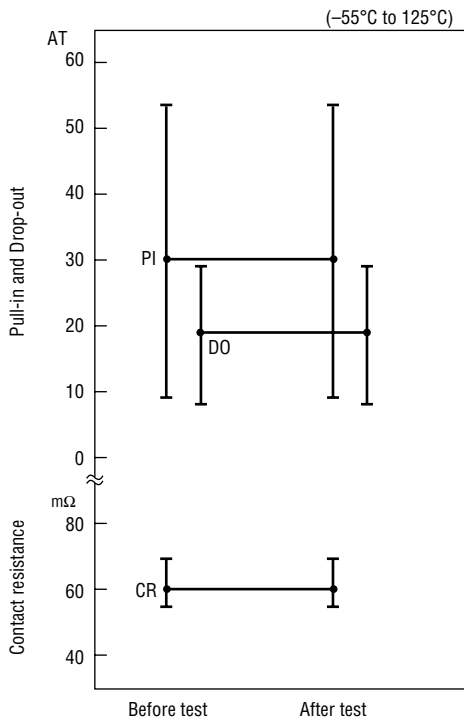

(3) Temperature and humidity cycle

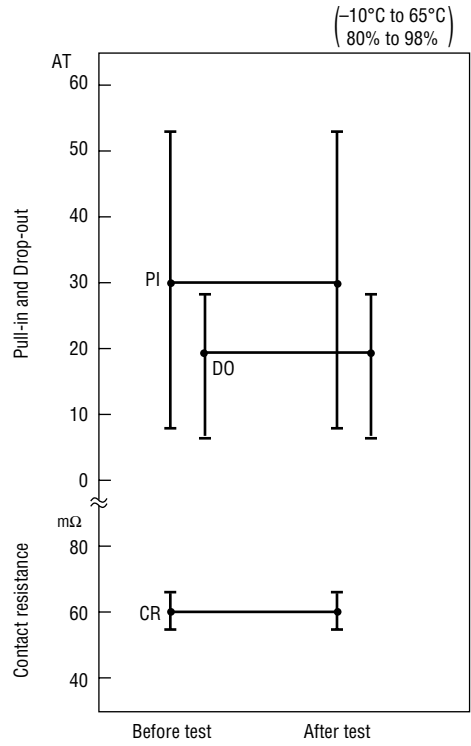

(4) High temperature storage test

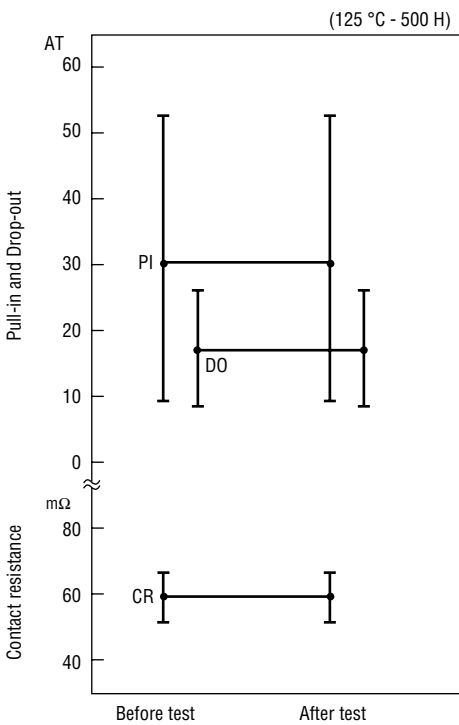

(5) Low temperature storage test

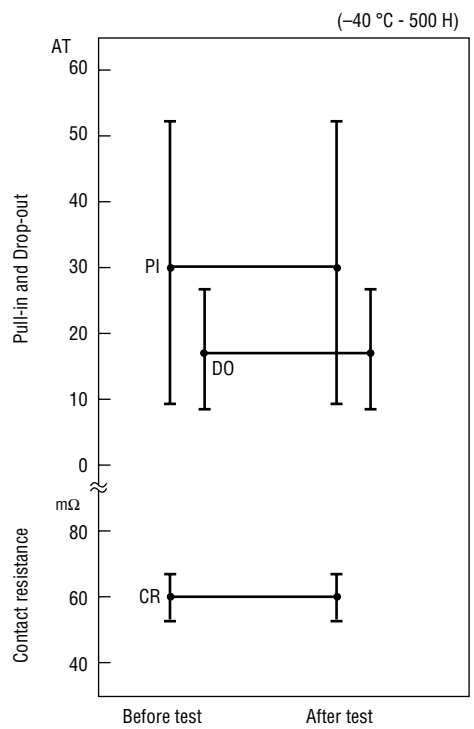

(6) Shock test

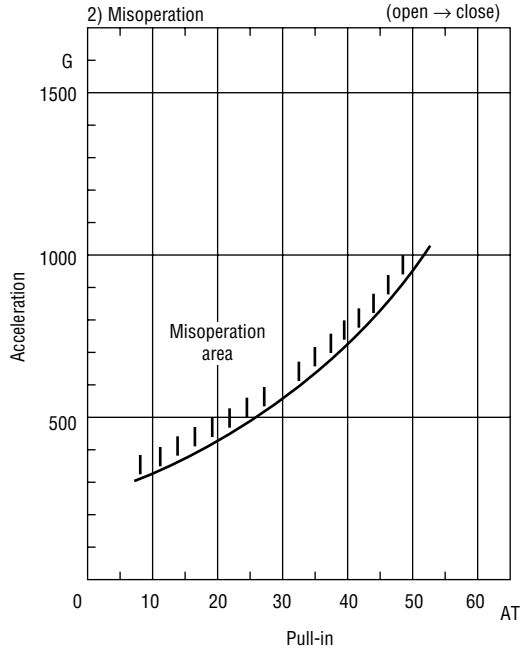
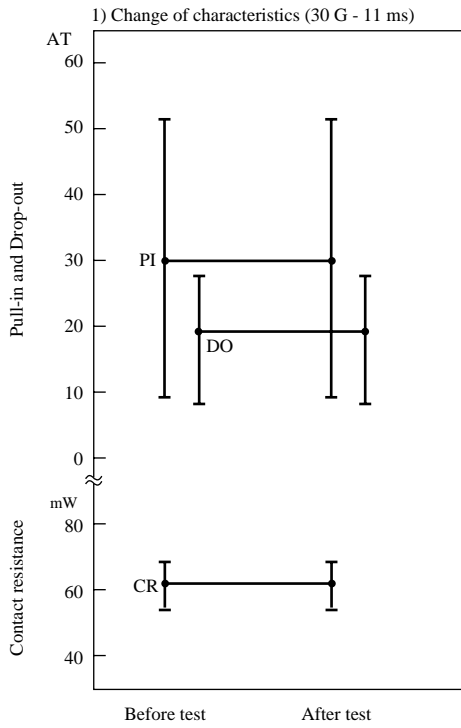

(7) Vibration test

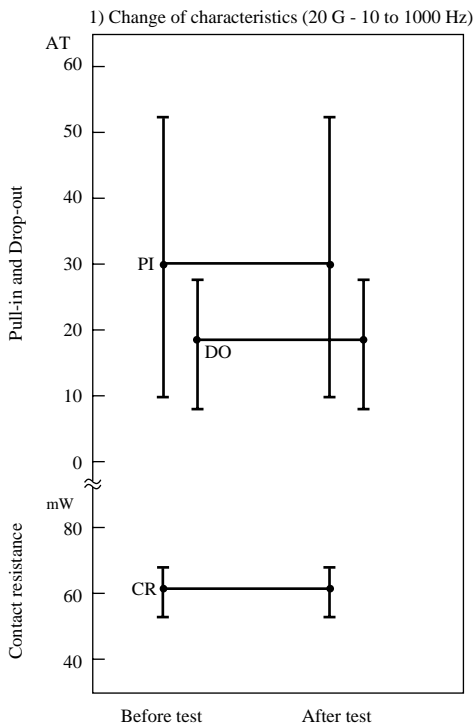



**LIFE EXPECTANCY DATA: ORD228VL**

Load conditions

Voltage : 5 VDC  
 Current : 100  $\mu$ A, 1 mA, 5 mA  
 Load : Resistive load

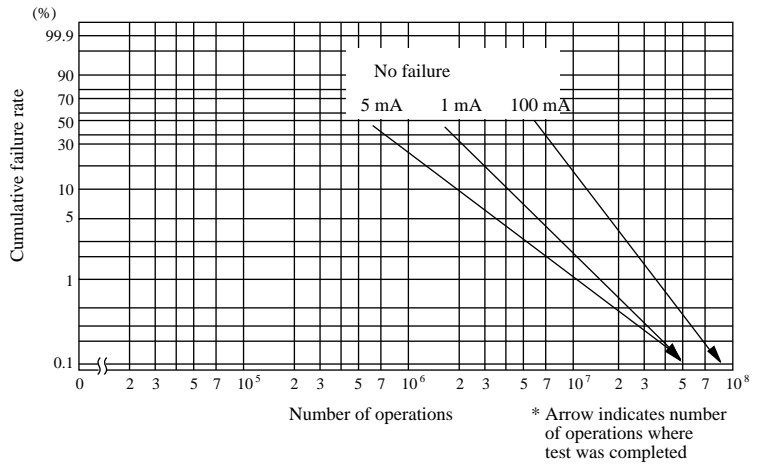

Load conditions

Voltage : 12 VDC  
 Current : 5 mA, 10 mA, 100 mA  
 Load : Resistive load

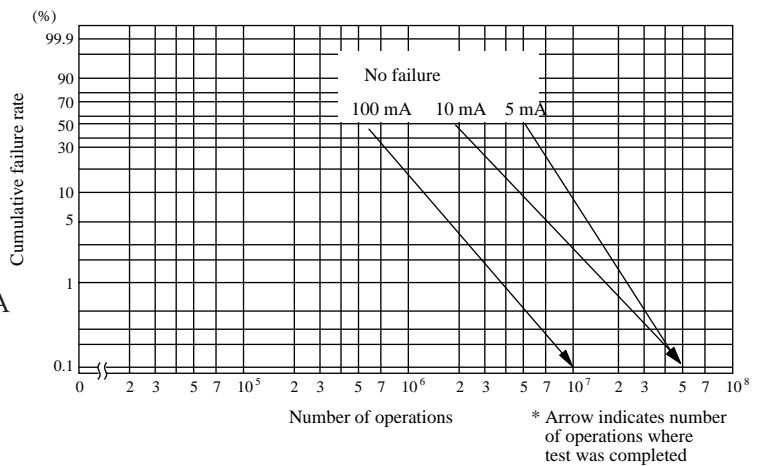

Load conditions

Voltage : 24 VDC  
 Current : 100 mA, 200 mA, 400 mA  
 Load : Resistive load

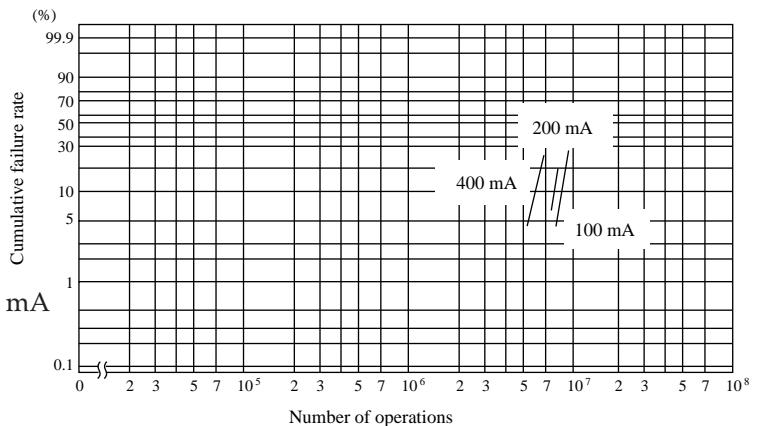

# REED SWITCH

## ORD2211

Lamp Load (12 V – 3.4 W Lamp Switching)

### GENERAL DESCRIPTION

The ORD2211 is a single-contact reed switch designed for direct opening or closing lamps of 12 V - 3.4 W. The contacts are sealed within the glass tube with inert gas to maintain contact reliability.

### Features

- (1) Reed contacts are hermetically sealed within a glass tube with inert gas and do not receive any influence from the external atmospheric environment.
- (2) Quick response
- (3) The structure comprises an operating system and electrical circuits coaxially. Reed switches are suited to applications in radio frequency.
- (4) Reed switches are compact and light weight.
- (5) Superior corrosion resistance and wear resistance of the contacts assures stable switching operation and long life.
- (6) With a permanent magnet installed, reed switches economically and easily become proximity switches.

### External Dimensions (Unit:mm)

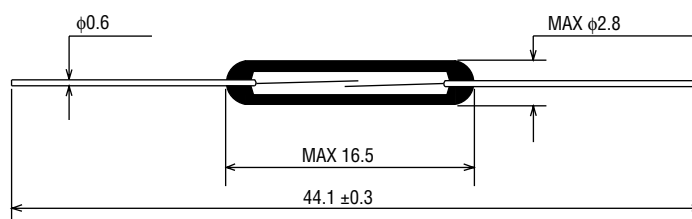

### APPLICATIONS OF REED SWITCHES

1. Automotive electronic devices
2. Control equipment
3. Communication equipment
4. Measurement equipment
5. Household appliances

**ELECTRICAL CHARACTERISTICS**

Parameter	Symbol	Condition	Rated Value			Unit
			Min.	Typ.	Max.	
Pull-in Value	PI	—	20	—	60	AT
Drop-out Value	DO	—	8	—	—	AT
Contact Resistance	CR	—	—	—	100	mΩ
Breakdown Voltage	—	PI≥20	200	—	—	VDC
Insulation Resistance	—	—	10 <sup>9</sup>	—	—	Ω
Electrostatic Capacitance	—	—	—	—	0.3	pF
Contact Rating	—	—	—	—	50 (12 V-3.4 W Lamp)	VA
Maximum Switching Voltage	—	—	—	—	100 <sup>DC</sup> / <sub>AC</sub>	V
Maximum Switching Current	—	—	—	—	0.5 (Inrush Current 3 A)	A
Maximum Carry Current	—	—	—	—	2.5	A

(1) Drop-out vs. Pull-in

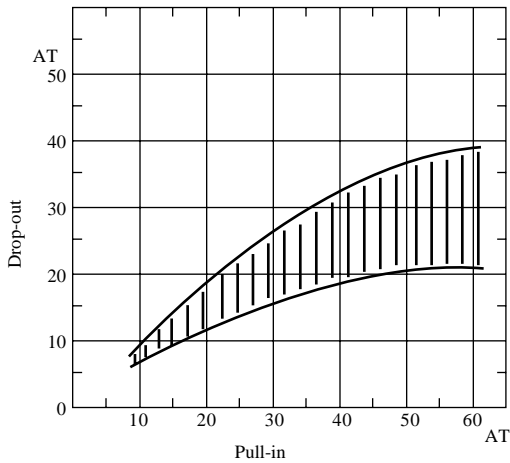

(2) Contact resistance

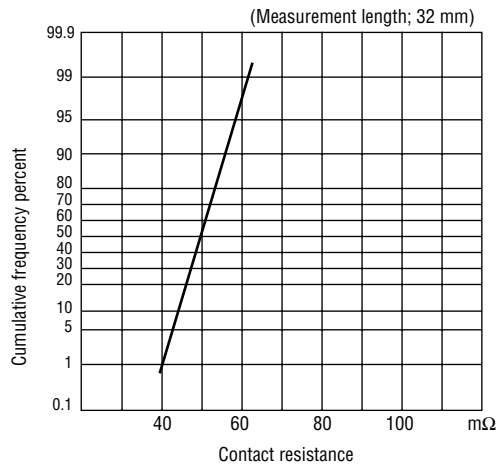

(3) Breakdown voltage

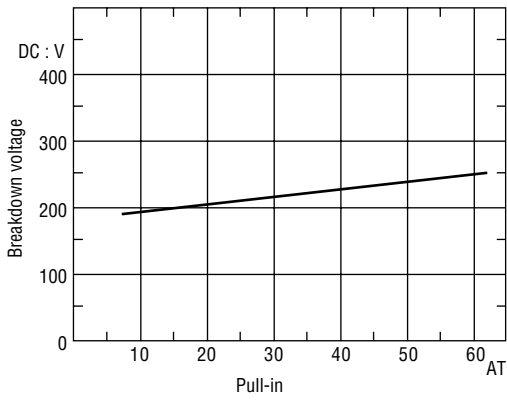

(4) Insulation resistance

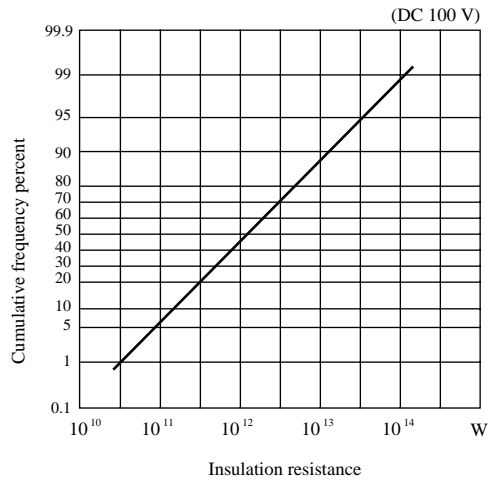

(5) Electrostatic capacitance

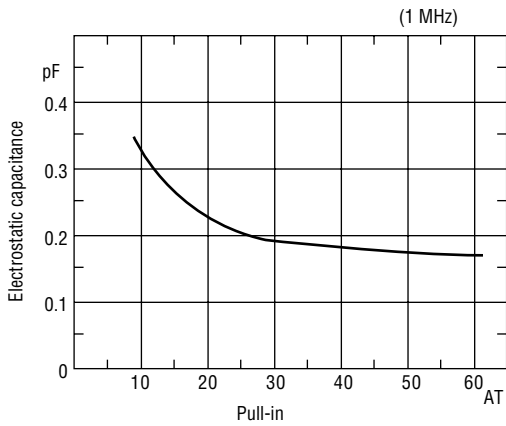

**OPERATING CHARACTERISTICS**

Parameter	Rated Value			Unit
	Min.	Typ.	Max.	
Operate Time	—	—	0.6	ms
Bounce Time	—	—	0.4	ms
Release Time	—	—	0.05	ms
Resonant Frequency	4100	4600	5100	Hz
Maximum Operating Frequency	—	—	500	Hz

(1) Operate time

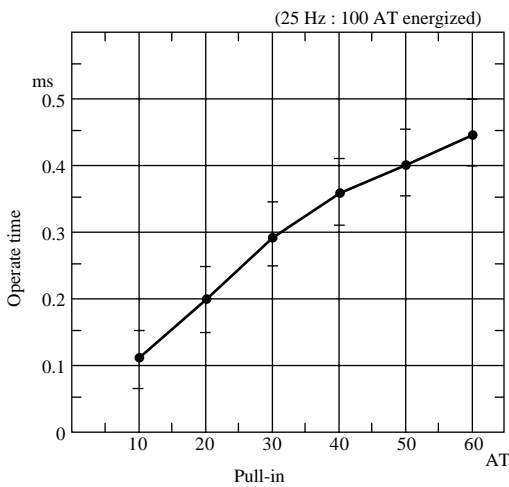

(2) Bounce time

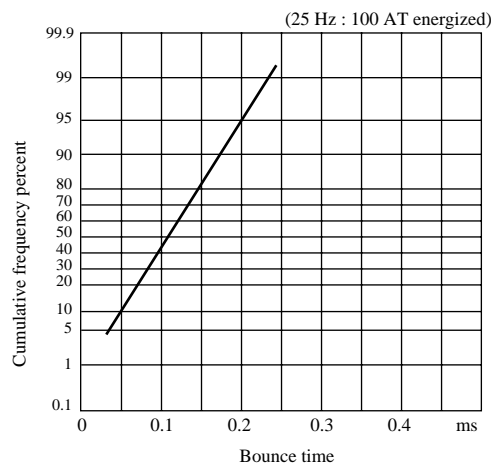

(3) Release time

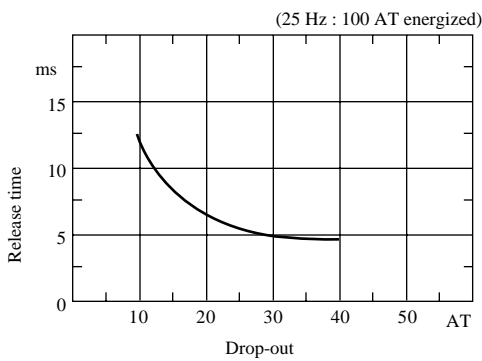

(4) Resonant frequency

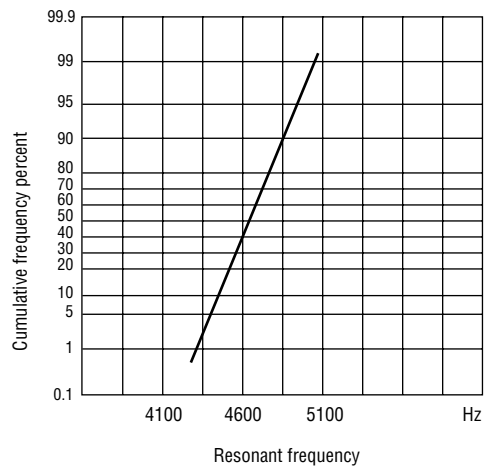

**MECHANICAL CHARACTERISTICS**

(1) Lead tensile test (static load)

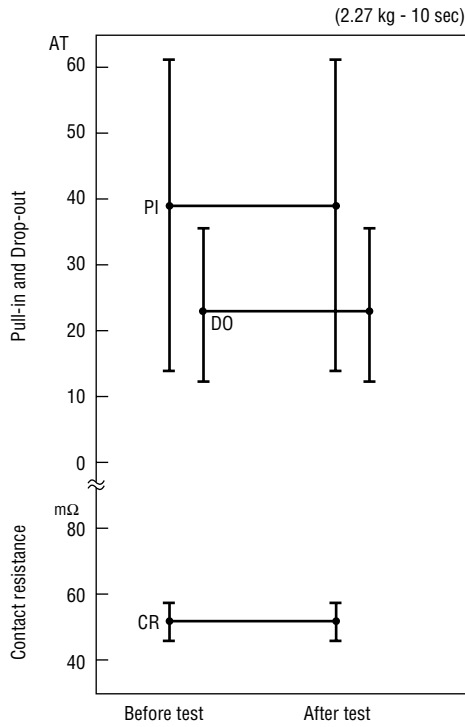

(2) Lead tensile strength

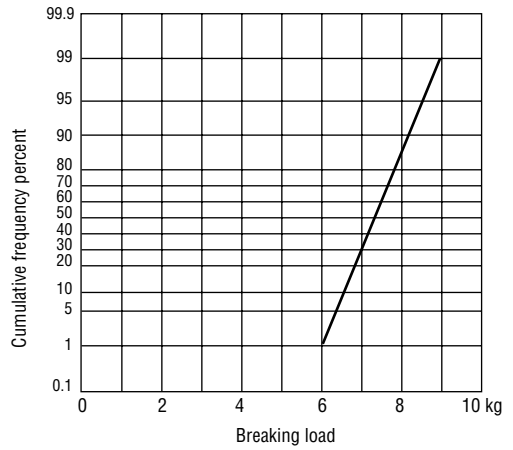

**ENVIRONMENTAL CHARACTERISTICS**

(1) Temperature characteristics

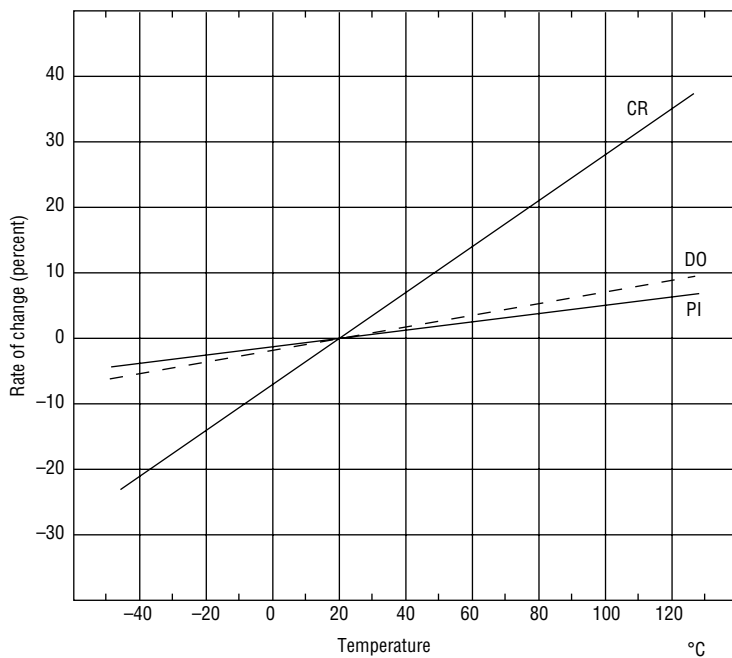

(2) Temperature cycle

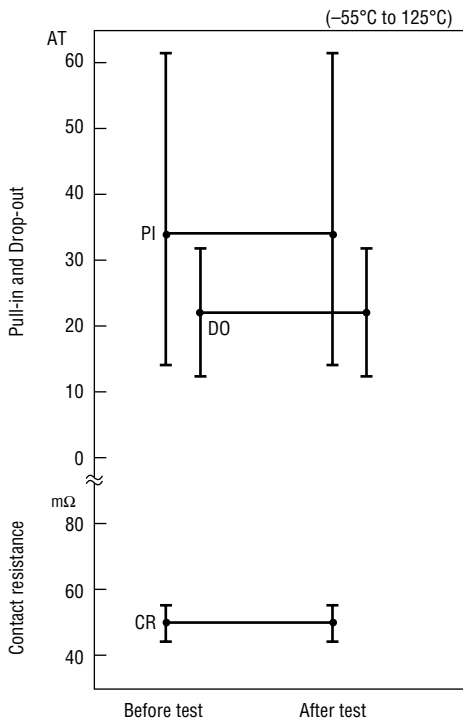

(3) Temperature and humidity cycle

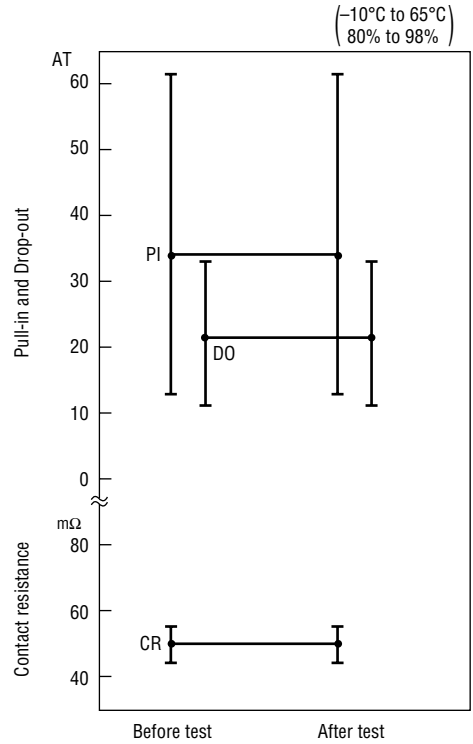

(4) High temperature storage test

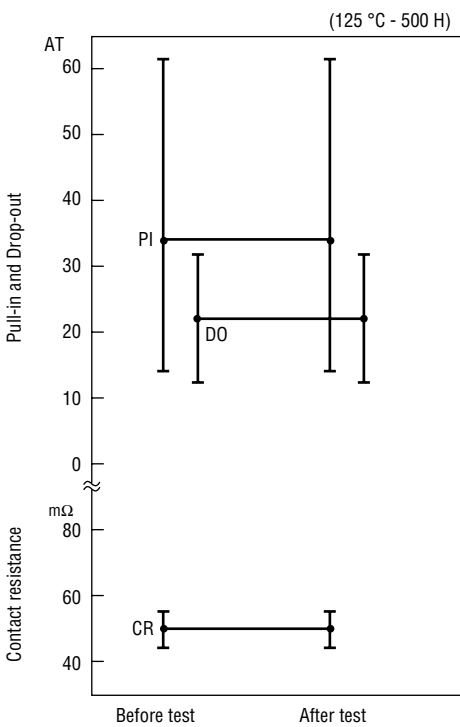

(5) Low temperature storage test

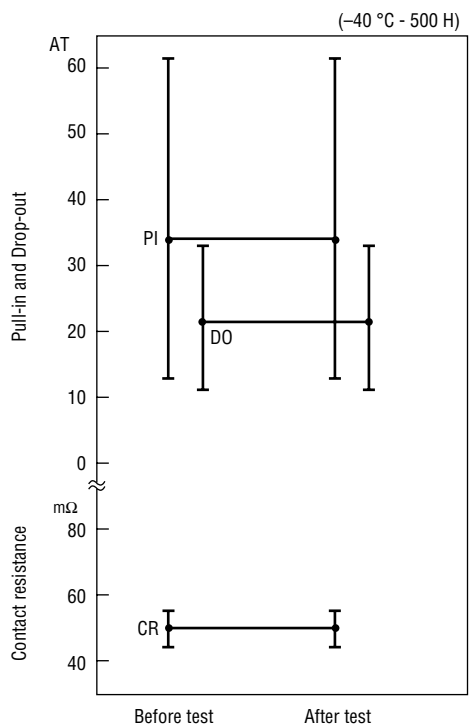

(6) Shock test

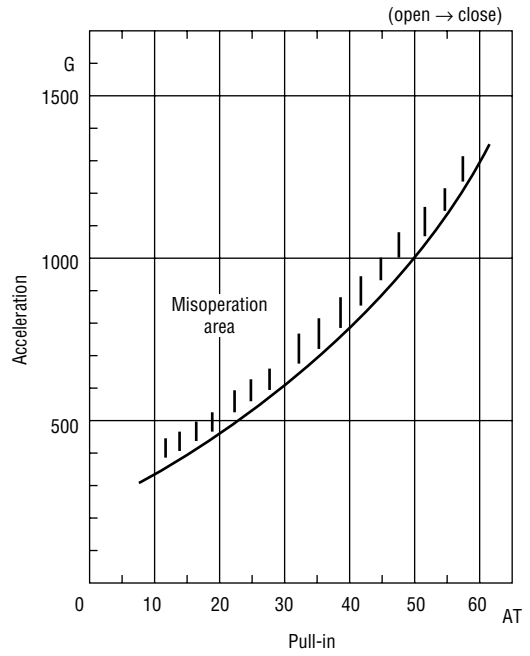
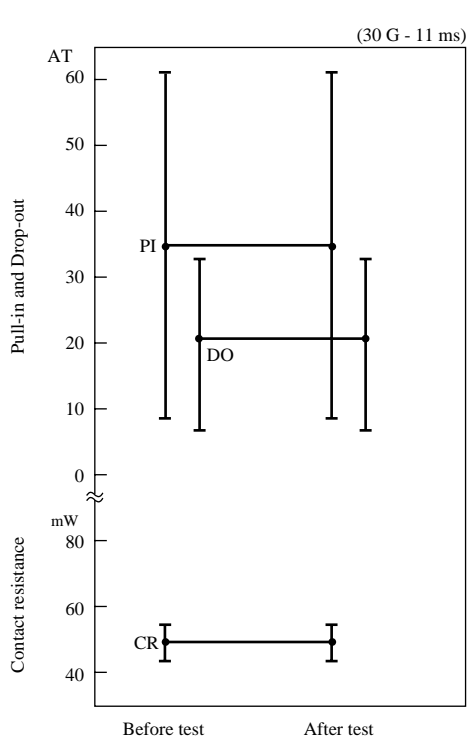

(7) Vibration test

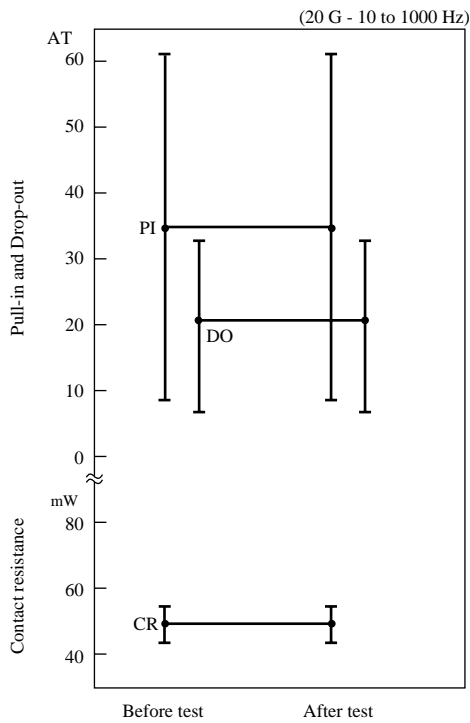



**LIFE EXPECTANCY DATA: ORD2211**

Load conditions

Voltage : 13, 14, 16 : VDC  
 Load : 12 V-3.4 W Lamp

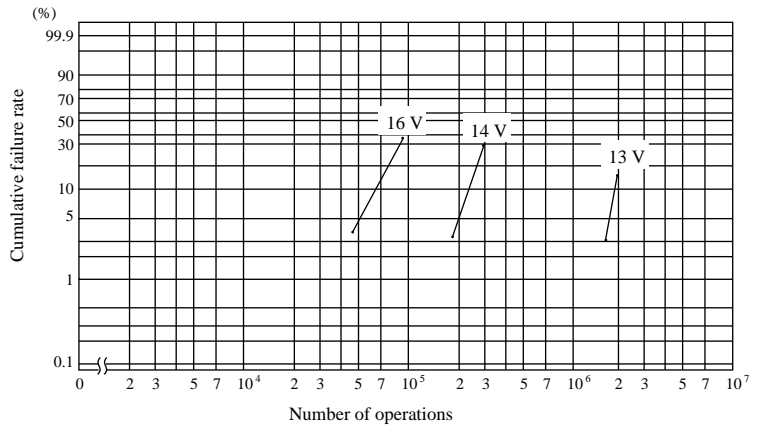

Load conditions

Voltage : 50 VDC  
 Current : 1 A  
 Load : Resistive load

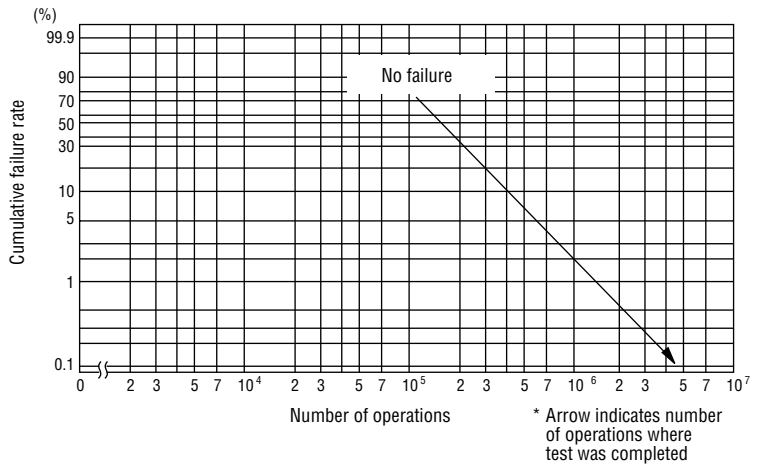

Load conditions

Voltage : 6 VDC  
 Current : 10 mA, 50 mA  
 Load : Resistive load

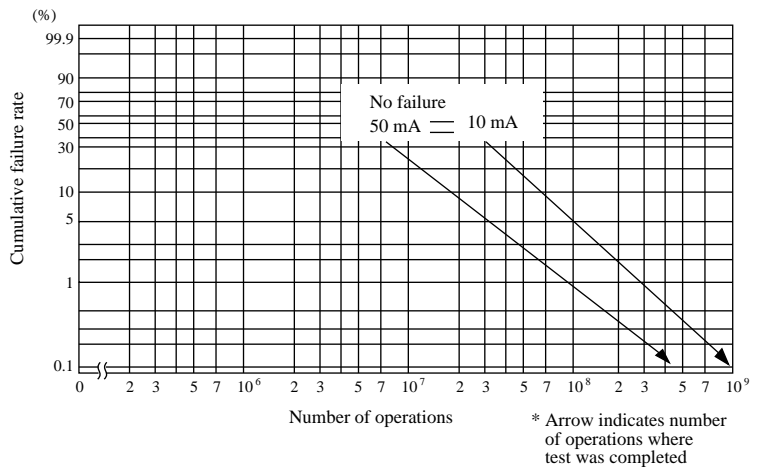

# REED SWITCH

## ORD2212

Closed Differential, Low Operating Noise

### GENERAL DESCRIPTION

The ORD2212 is a single-contact reed switch designed for the purpose of low operating noise and closed differential motion. The contacts are sealed within the glass tube with inert gas to maintain contact reliability.

### Features

- (1) Reed contacts are hermetically sealed within a glass tube with inert gas and do not receive any influence from the external atmospheric environment.
- (2) Quick response
- (3) The structure comprises an operating system and electrical circuits coaxially. Reed switches are suited to applications in radio frequency.
- (4) Reed switches are compact and light weight.
- (5) Superior corrosion resistance and wear resistance of the contacts assures stable switching operation and long life.
- (6) With a permanent magnet installed, reed switches economically and easily become proximity switches.

### External Dimensions (Unit:mm)

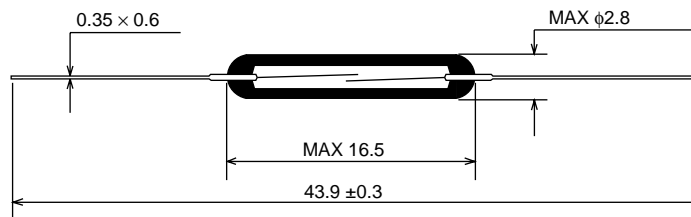

### APPLICATIONS OF REED SWITCHES

1. Automotive electronic devices
2. Control equipment
3. Communication equipment
4. Measurement equipment
5. Household appliances

**ELECTRICAL CHARACTERISTICS**

Parameter	Symbol	Condition	Rated Value			Unit
			Min.	Typ.	Max.	
Pull-in Value	PI	—	15	—	35	AT
Drop-out Value	DO	PI>20	—	DO/PI≥0.8	—	—
	DO	PI<20	—	DO/PI≥0.7	—	—
Contact Resistance	CR	—	—	—	100	mΩ
Breakdown Voltage	—	—	150	—	—	VDC
Insulation Resistance	—	—	10 <sup>9</sup>	—	—	Ω
Electrostatic Capacitance	—	—	—	—	0.5	pF
Contact Rating	—	—	—	—	10	VA
Maximum Switching Voltage	—	—	—	—	100 <sup>DC</sup> <sub>AC</sub>	V
Maximum Switching Current	—	—	—	—	0.2	A
Maximum Carry Current	—	—	—	—	0.5	A

(1) Drop-out vs. Pull-in

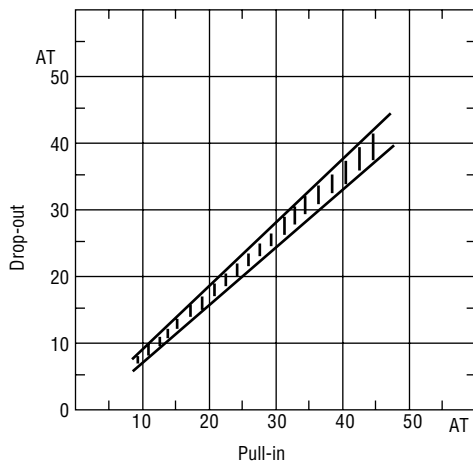

(2) Contact resistance

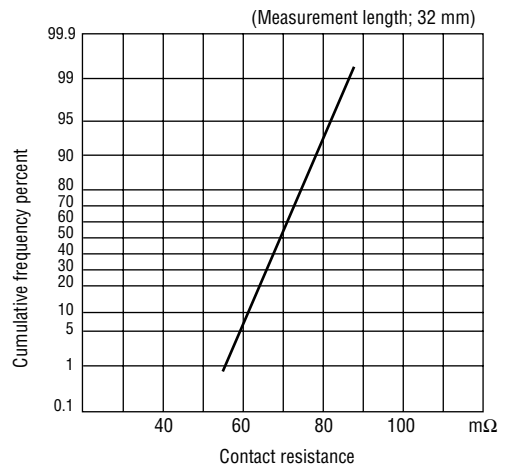

(3) Breakdown voltage

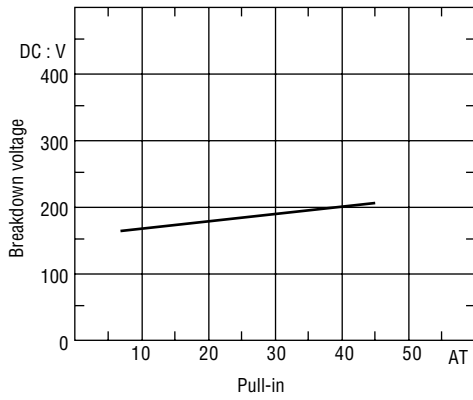

(4) Insulation resistance

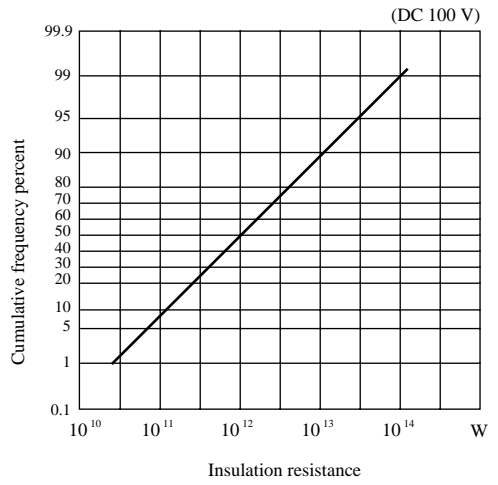

(5) Electrostatic capacitance

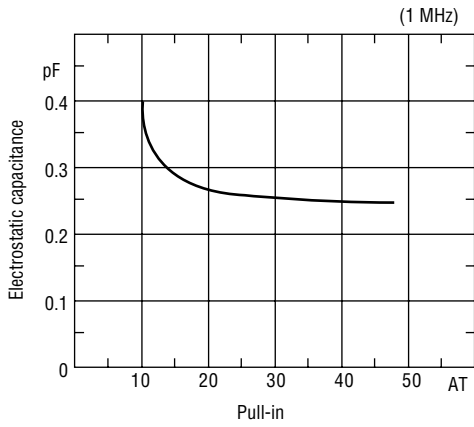

**OPERATING CHARACTERISTICS**

Parameter	Rated Value			Unit
	Min.	Typ.	Max.	
Operate Time	—	—	0.4	ms
Bounce Time	—	—	1.0	ms
Release Time	—	—	0.05	ms
Resonant Frequency	3400	3900	4400	Hz
Maximum Operating Frequency	—	—	500	Hz

(1) Operate time

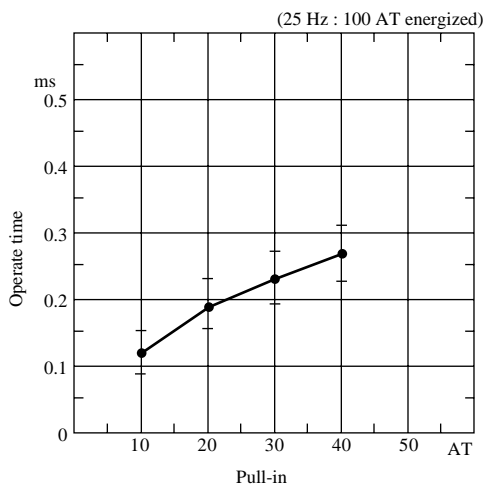

(2) Bounce time

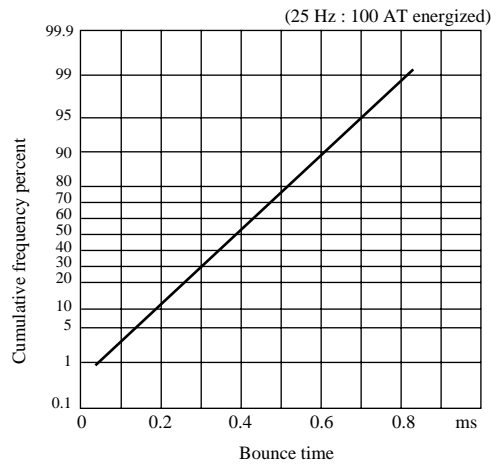

(3) Release time

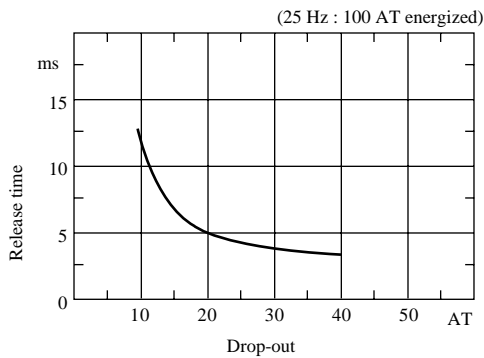

(4) Resonant frequency

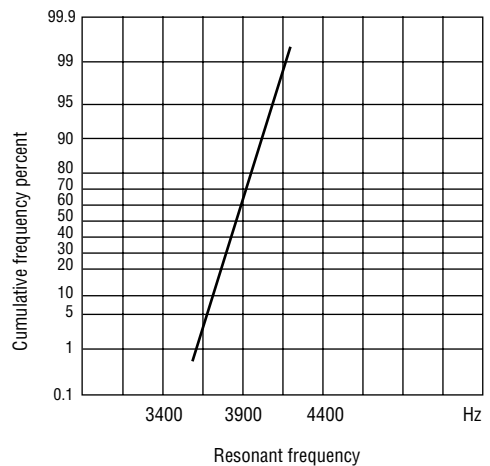

### MECHANICAL CHARACTERISTICS

(1) Lead tensile test (static load)

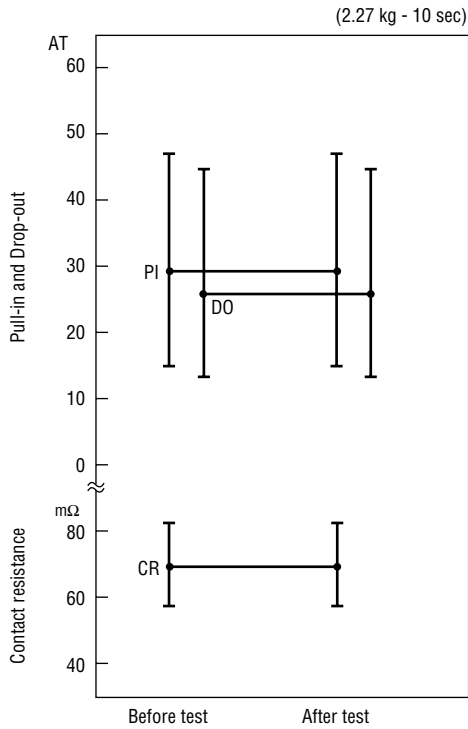

(2) Lead tensile strength

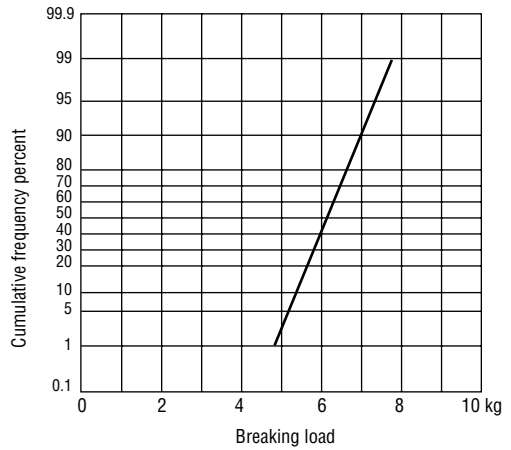

### ENVIRONMENTAL CHARACTERISTICS

(1) Temperature characteristics

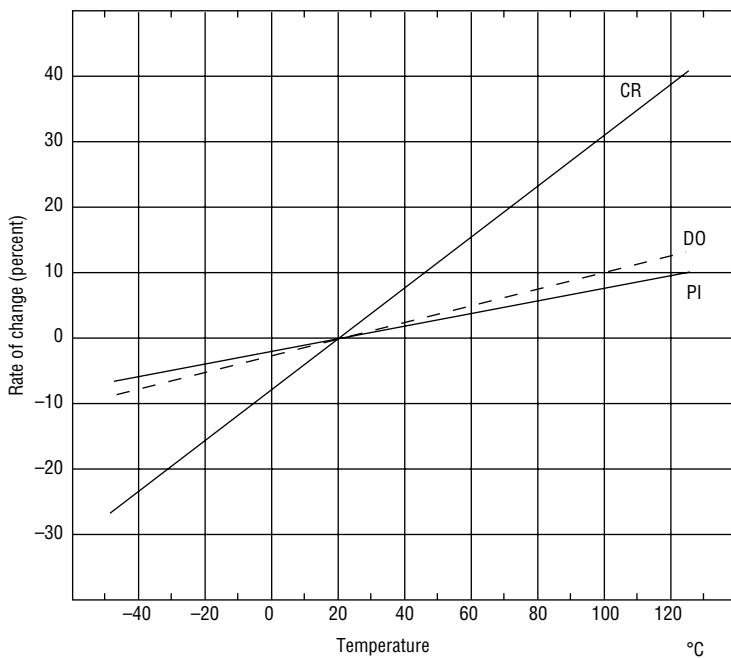

(2) Temperature cycle

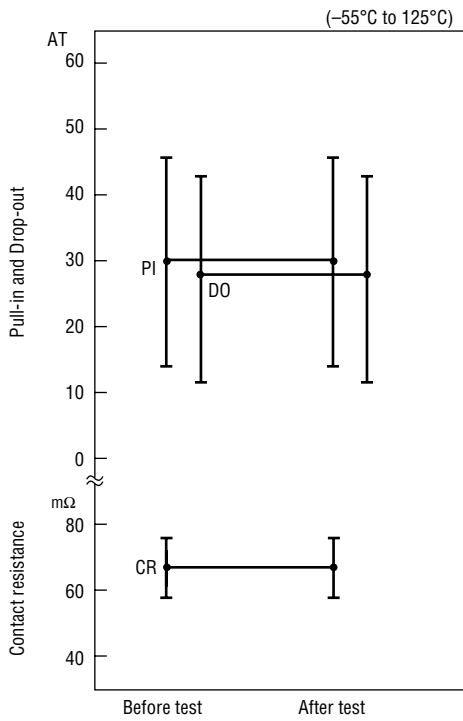

(3) Temperature and humidity cycle

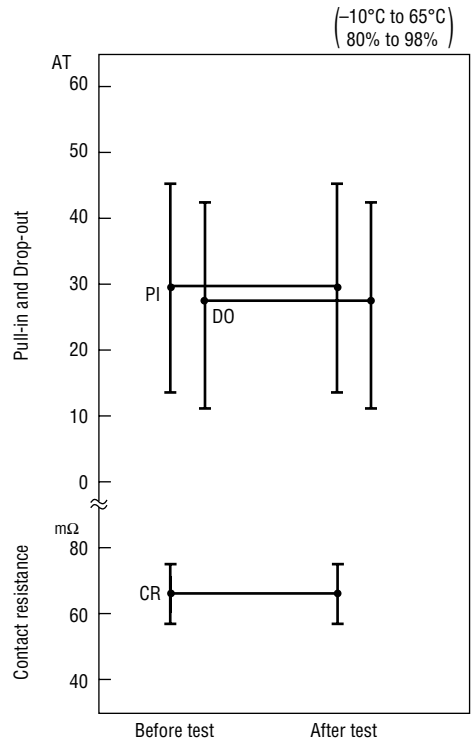

(4) High temperature storage test

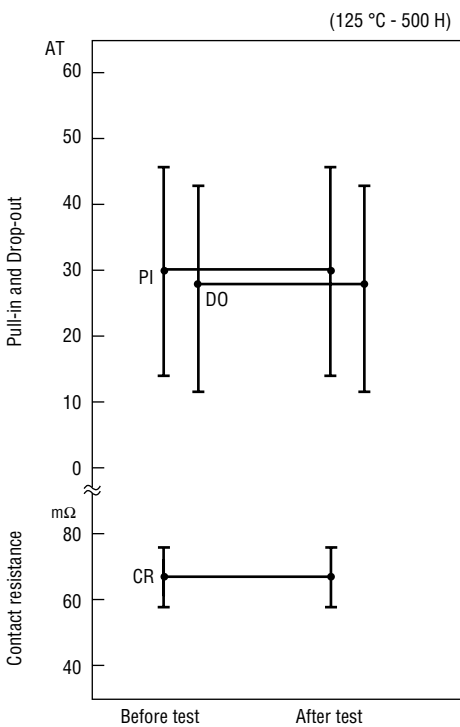

(5) Low temperature storage test

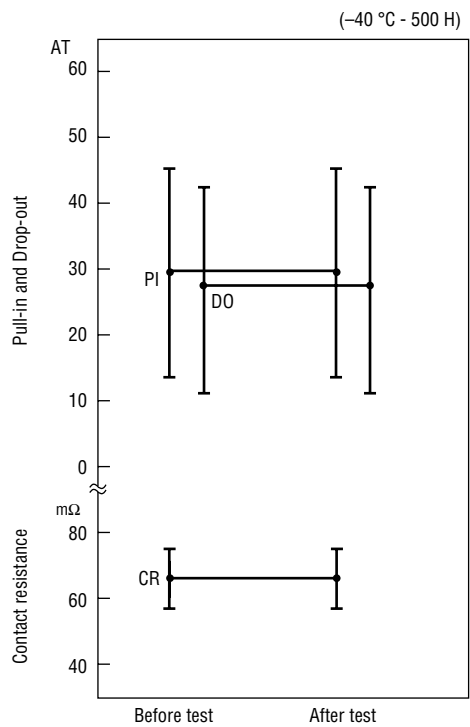

(6) Shock test

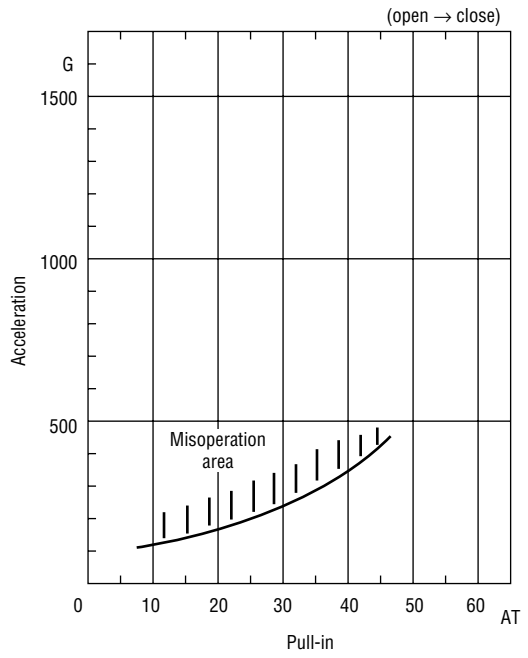
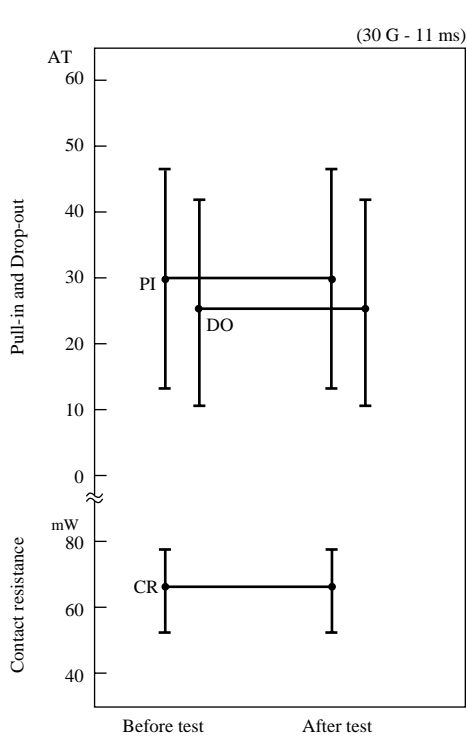

(7) Vibration test

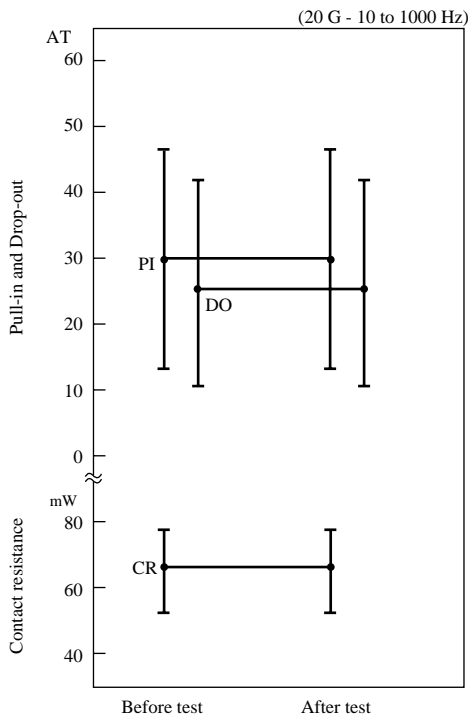



**LIFE EXPECTANCY DATA: ORD2212**

Load conditions

Voltage : 5 VDC  
 Current : 100  $\mu$ A, 1 mA, 5 mA  
 Load : Resistive load

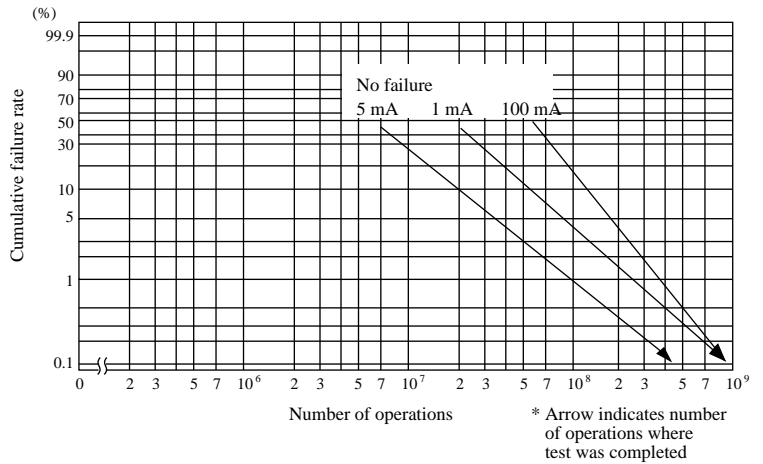

Load conditions

Voltage : 6 VDC  
 Current : 10 mA, 20 mA  
 Load : Resistive load

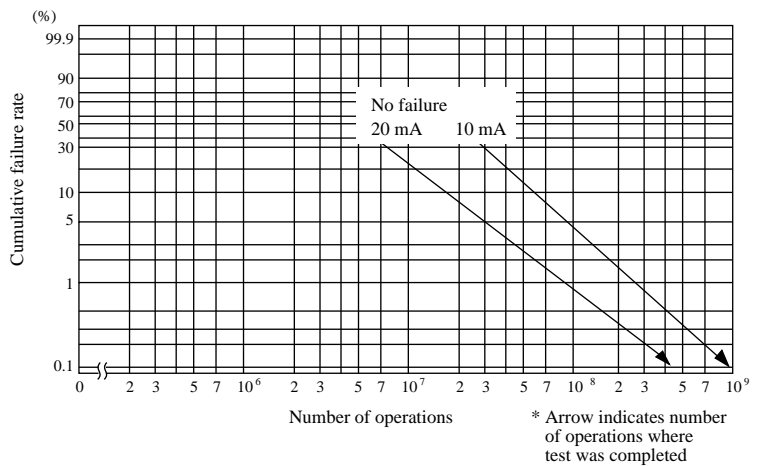

Load conditions

Voltage : 15 VDC  
 Current : 5 mA, 10 mA  
 Load : Resistive load

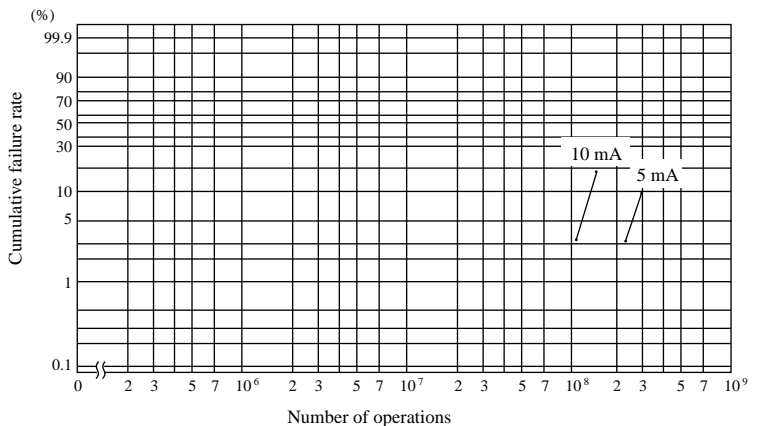

# REED SWITCH

## ORD229

High Breakdown Voltage, High Power (AC 200 V Switching)

### GENERAL DESCRIPTION

The ORD229 is a single-contact reed switch designed for high breakdown voltage of 600 VDC and high power of AC 70 VA and DC 50 W. The contacts are sealed within the glass tube with inert gas to maintain contact reliability.

### Features

- (1) Reed contacts are hermetically sealed within a glass tube with inert gas and do not receive any influence from the external atmospheric environment.
- (2) Quick response
- (3) The structure comprises an operating system and electrical circuits coaxially. Reed switches are suited to applications in radio frequency.
- (4) Reed switches are compact and light weight.
- (5) Superior corrosion resistance and wear resistance of the contacts assures stable switching operation and long life.
- (6) With a permanent magnet installed, reed switches economically and easily become proximity switches.

### External Dimensions (Unit:mm)

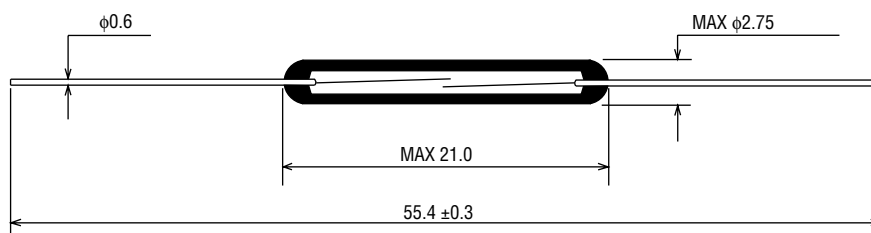

### APPLICATIONS OF REED SWITCHES

1. Automotive electronic devices
2. Control equipment
3. Communication equipment
4. Measurement equipment
5. Household appliances

**ELECTRICAL CHARACTERISTICS**

Parameter	Symbol	Condition	Rated Value			Unit
			Min.	Typ.	Max.	
Pull-in Value	PI	—	20	—	50	AT
Drop-out Value	DO	—	6	—	—	AT
Contact Resistance	CR	—	—	—	100	mΩ
Breakdown Voltage	—	PI>35	600	—	—	VDC
Breakdown Voltage	—	PI 20 to 35	500	—	—	VDC
Insulation Resistance	—	—	10 <sup>10</sup>	—	—	Ω
Electrostatic Capacitance	—	—	—	—	0.5	pF
Contact Rating	—	—	—	—	50	W
Contact Rating	—	—	—	—	70	VA
Maximum Switching Voltage	—	—	—	—	300 AC	V
Maximum Switching Voltage	—	—	—	—	350 DC	V
Maximum Switching Current	—	—	—	—	DC0.7/AC0.5	A
Maximum Carry Current	—	—	—	—	2.5	A

(1) Drop-out vs. Pull-in

(2) Contact resistance

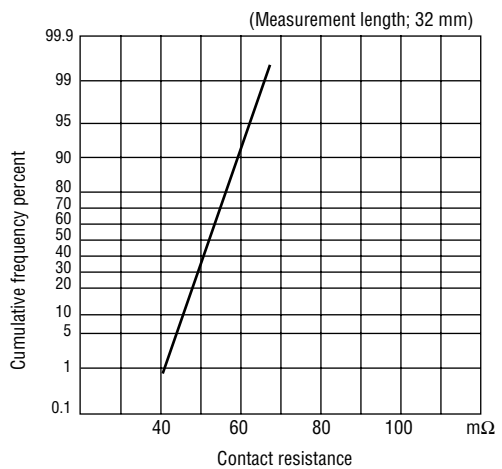
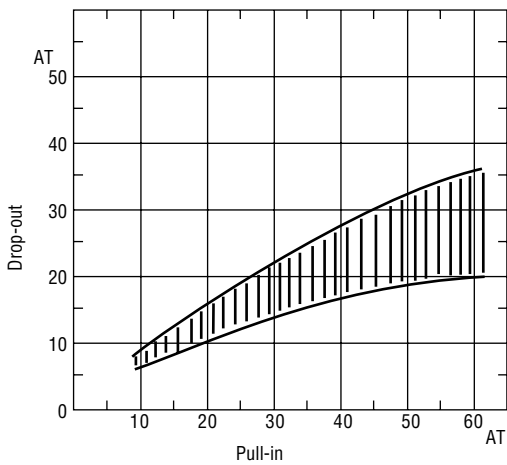

(3) Breakdown voltage

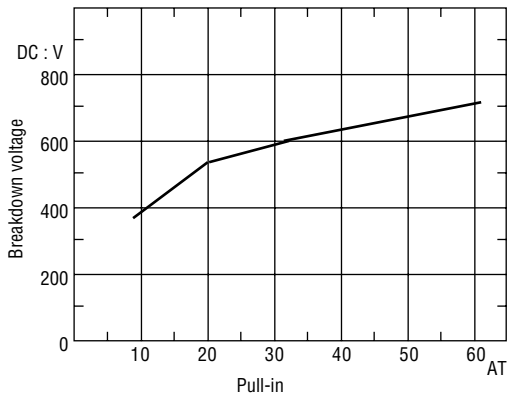

(4) Insulation resistance

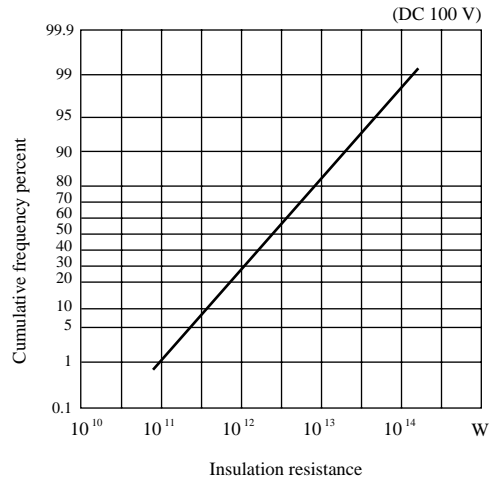

(5) Electrostatic capacitance

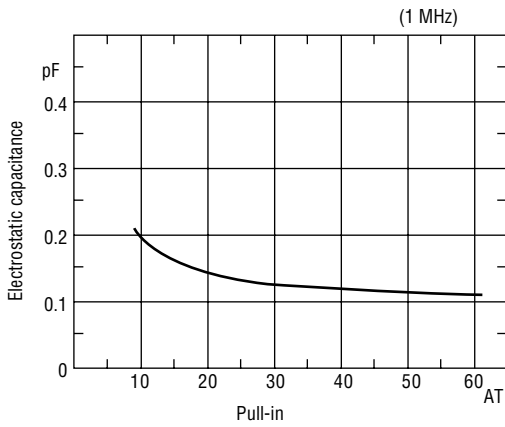

**OPERATING CHARACTERISTICS**

Parameter	Rated Value			Unit
	Min.	Typ.	Max.	
Operate Time	—	—	0.6	ms
Bounce Time	—	—	0.5	ms
Release Time	—	—	0.05	ms
Resonant Frequency	2250	2500	2750	Hz
Maximum Operating Frequency	—	—	500	Hz

(1) Operate time

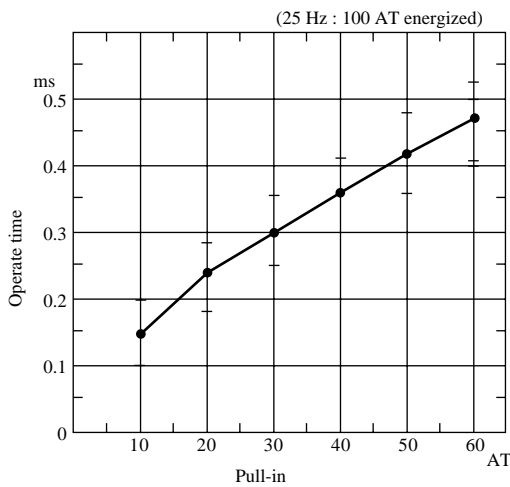

(2) Bounce time

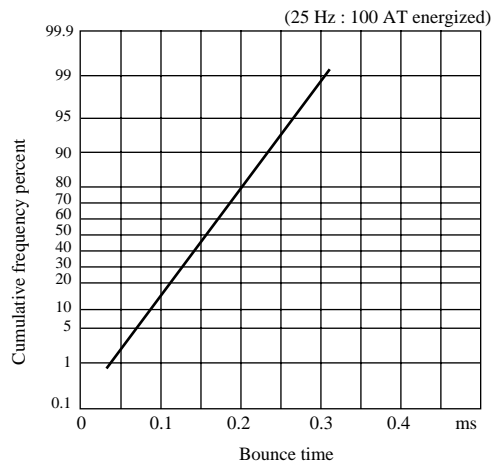

(3) Release time

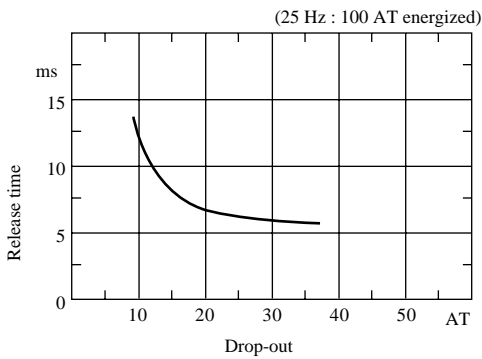

(4) Resonant frequency

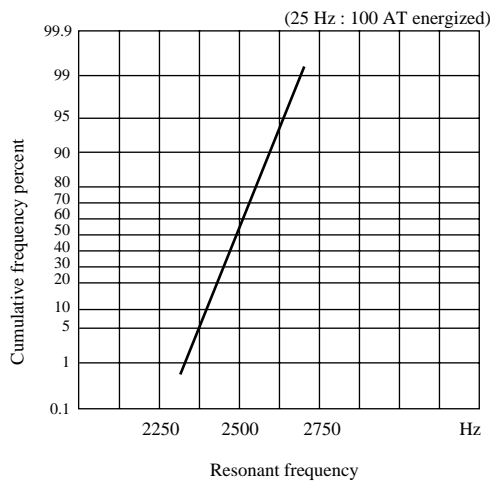

**MECHANICAL CHARACTERISTICS**

(1) Lead tensile test (static load)

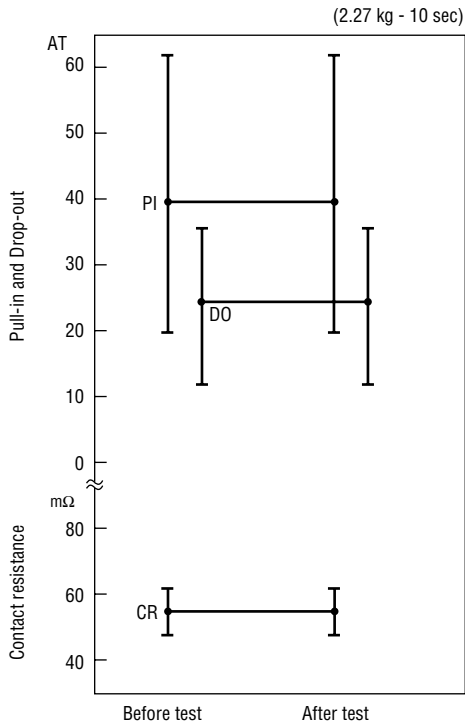

(2) Lead tensile strength

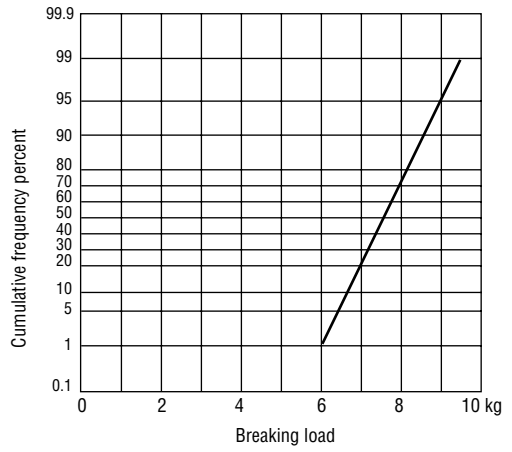

**ENVIRONMENTAL CHARACTERISTICS**

(1) Temperature characteristics

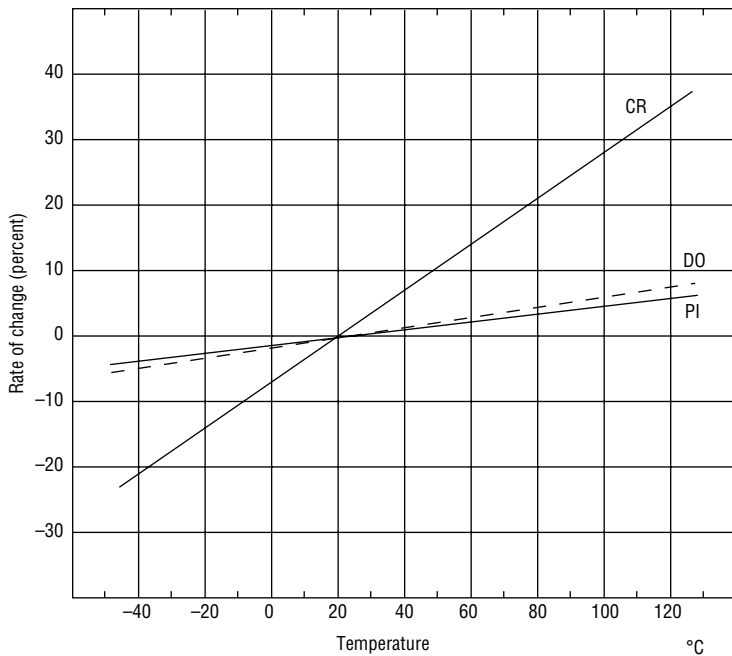

(2) Temperature cycle

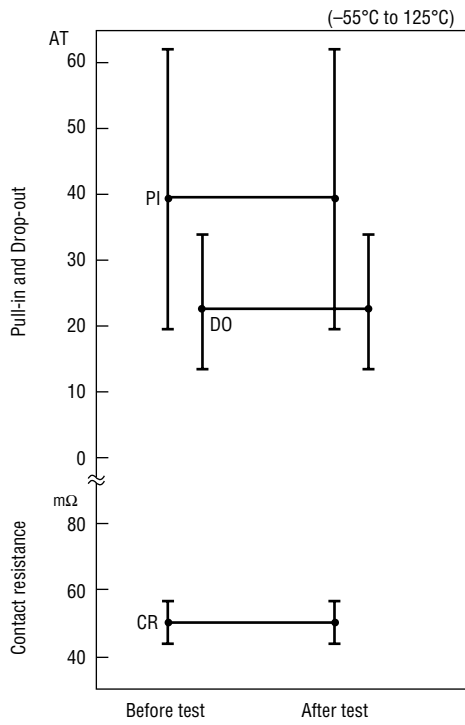

(3) Temperature and humidity cycle

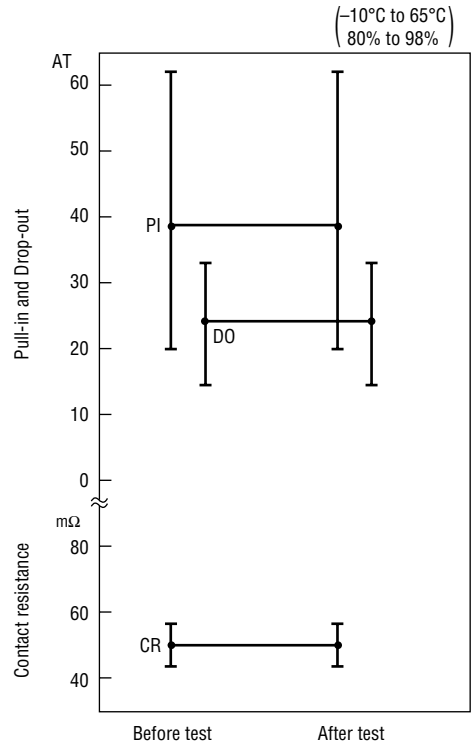

(4) High temperature storage test

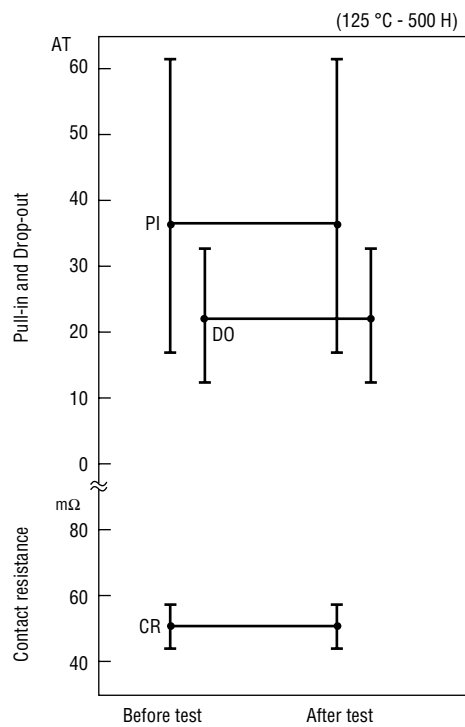

(5) Low temperature storage test

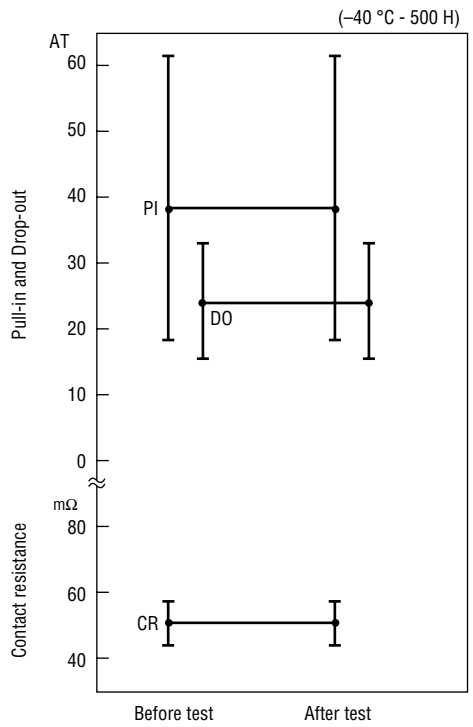

(6) Shock test

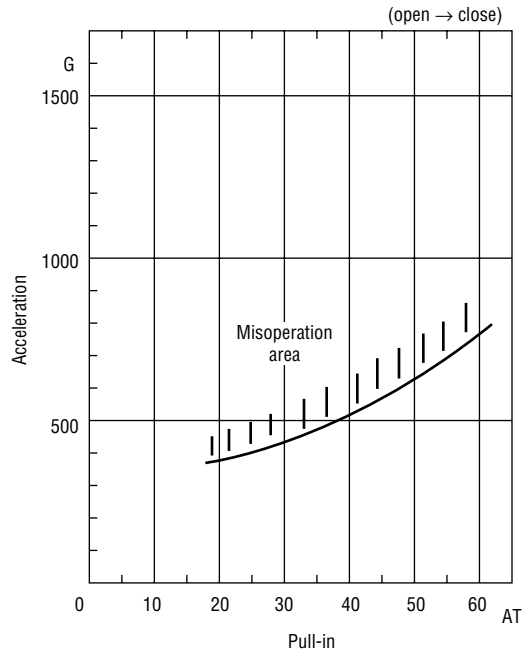
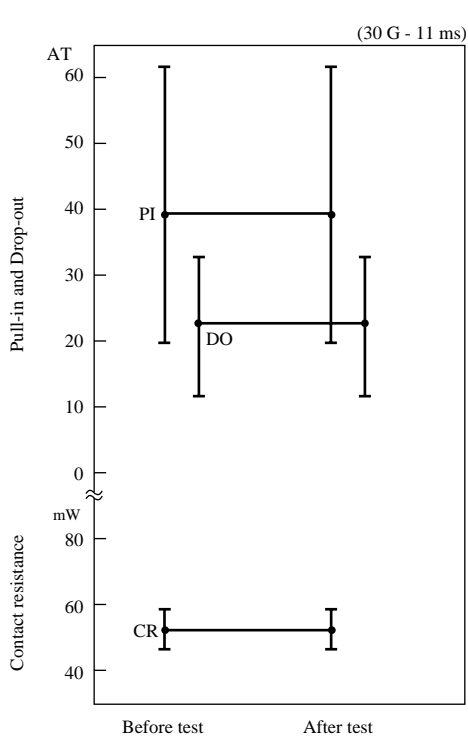

(7) Vibration test

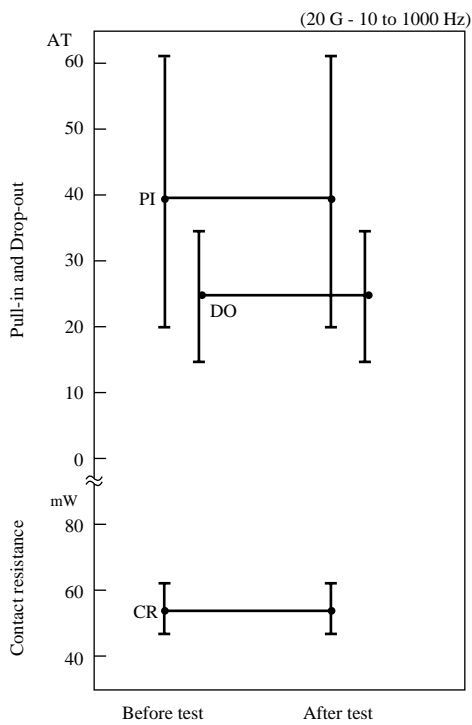



**LIFE EXPECTANCY DATA: ORD229**

Load conditions

Voltage : 200 VAC  
 Current : 200 mA, 250 mA  
 Load : Resistive load

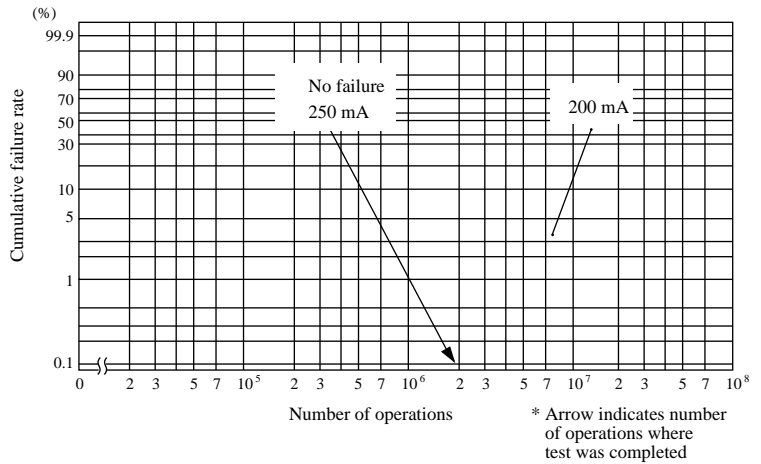

Load conditions

Voltage : 350 VDC, 270 VDC  
 Current : 1 mA, 270  $\mu$ A  
 Load : Resistive load

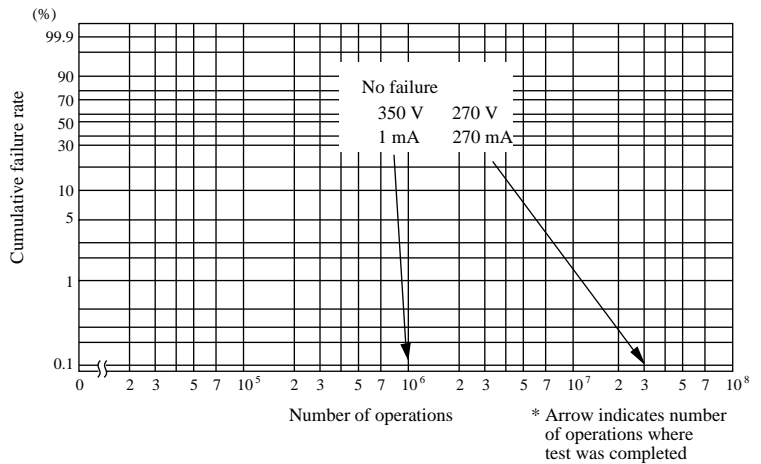

Load conditions

Voltage : 100 VDC, 50 VDC  
 Current : 0.5 A, 1.0 A, 0.5 A  
 Load : Resistive load

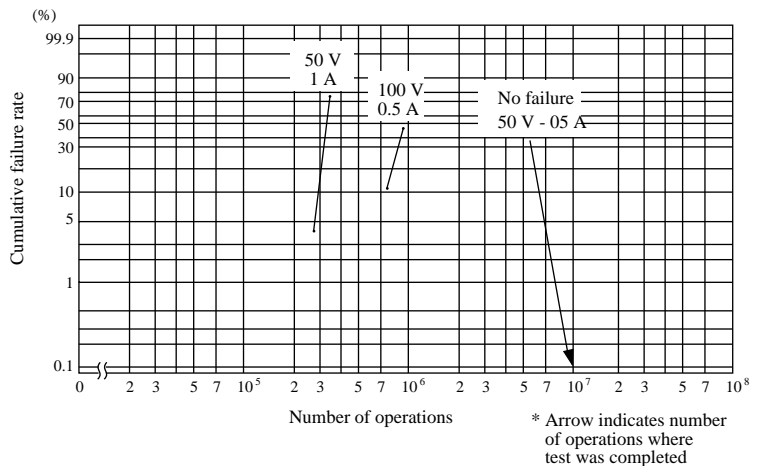

# REED SWITCH

## ORD2210

### High Power

#### GENERAL DESCRIPTION

The ORD2210 is a single-contact reed switch designed for high current of 1.0 A DC and 0.7 A AC and high power of AC 70 VA and DC 50 W. The contacts are sealed within the glass tube with inert gas to maintain contact reliability.

#### Features

- (1) Reed contacts are hermetically sealed within a glass tube with inert gas and do not receive any influence from the external atmospheric environment.
- (2) Quick response
- (3) The structure comprises an operating system and electrical circuits coaxially. Reed switches are suited to applications in radio frequency.
- (4) Reed switches are compact and light weight.
- (5) Superior corrosion resistance and wear resistance of the contacts assures stable switching operation and long life.
- (6) With a permanent magnet installed, reed switches economically and easily become proximity switches.

#### External Dimensions (Unit:mm)

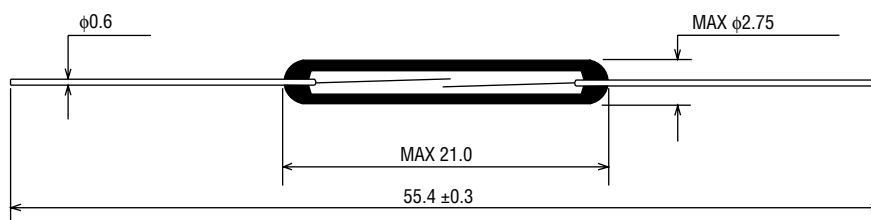

#### APPLICATIONS OF REED SWITCHES

1. Automotive electronic device
2. Control equipment
3. Communication equipment
4. Measurement equipment
5. Household appliances

**ELECTRICAL CHARACTERISTICS**

Parameter	Symbol	Condition	Rated Value			Unit
			Min.	Typ.	Max.	
Pull-in Value	PI	—	15	—	60	AT
Drop-out Value	DO	—	7	—	—	AT
Contact Resistance	CR	—	—	—	100	mΩ
Breakdown Voltage	—	PI>20	250	—	—	VDC
Breakdown Voltage	—	PI<20	200	—	—	VDC
Insulation Resistance	—	—	10 <sup>10</sup>	—	—	Ω
Electrostatic Capacitance	—	—	—	—	0.5	pF
Contact Rating	—	—	—	—	50	W
Contact Rating	—	—	—	—	70	VA
Maximum Switching Voltage	—	—	—	—	200 DC	V
Maximum Switching Voltage	—	—	—	—	150 AC	V
Maximum Switching Current	—	—	—	—	1.0 DC	A
Maximum Switching Current	—	—	—	—	0.7 AC	A
Maximum Carry Current	—	—	—	—	2.5	A

(1) Drop-out vs. Pull-in

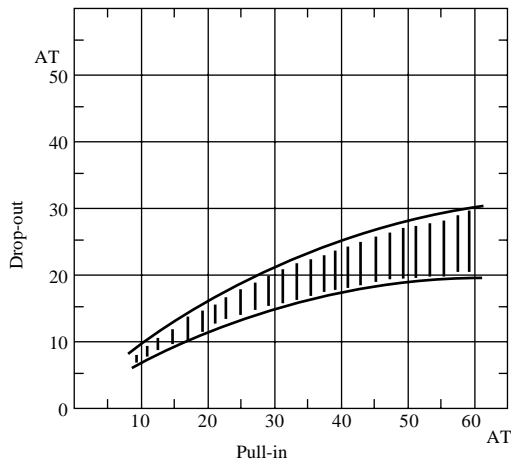

(2) Contact resistance

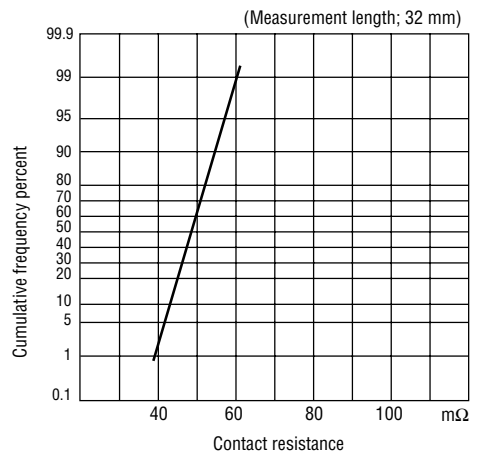

(3) Breakdown voltage

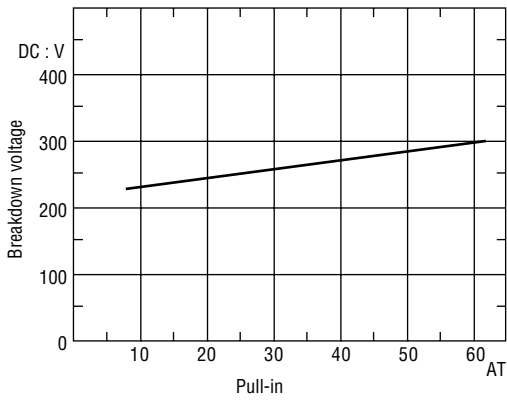

(4) Insulation resistance

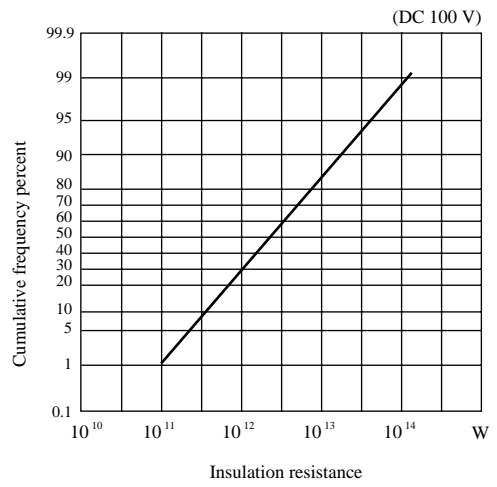

(5) Electrostatic capacitance

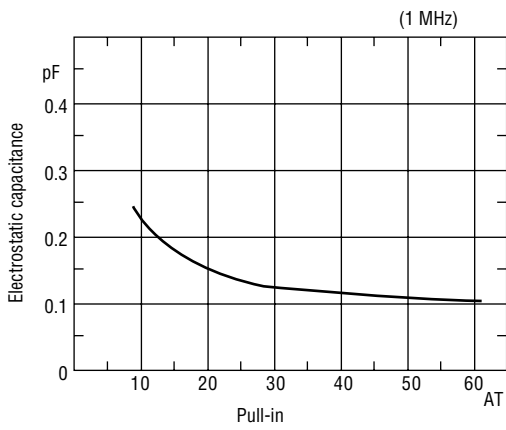

**OPERATING CHARACTERISTICS**

Parameter	Rated Value			Unit
	Min.	Typ.	Max.	
Operate Time	—	—	0.6	ms
Bounce Time	—	—	0.5	ms
Release Time	—	—	0.05	ms
Resonant Frequency	2250	2500	2750	Hz
Maximum Operating Frequency	—	—	500	Hz

(1) Operate time

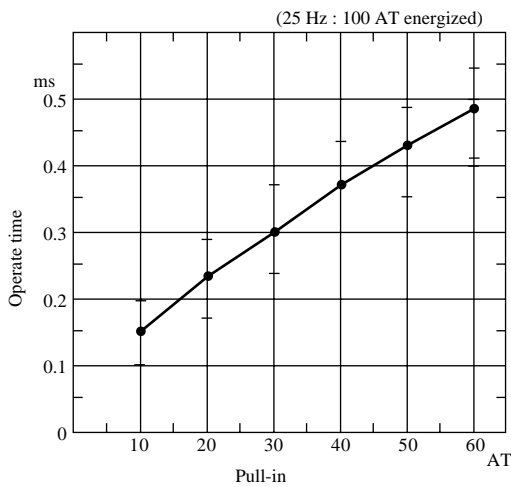

(2) Bounce time

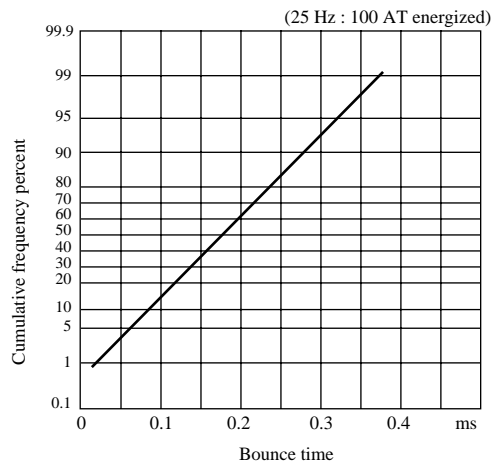

(3) Release time

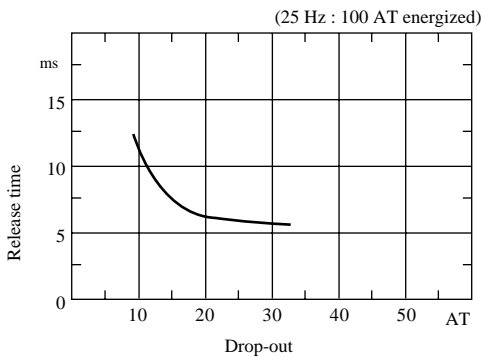

(4) Resonant frequency

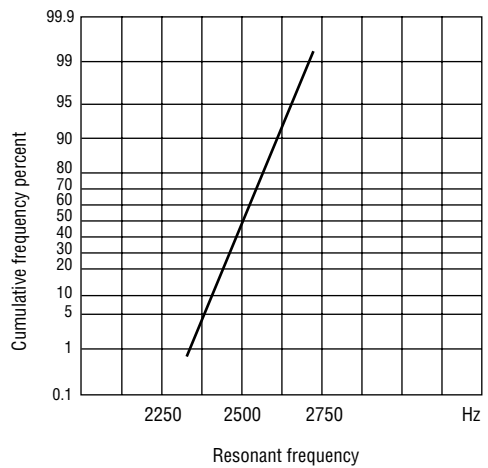

### MECHANICAL CHARACTERISTICS

(1) Lead tensile test (static load)

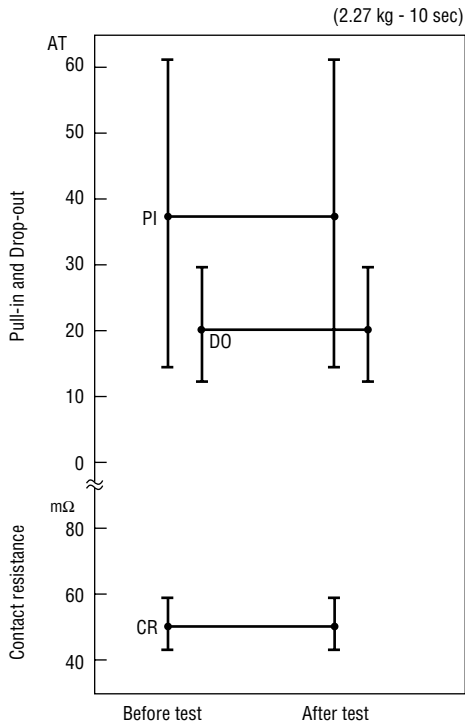

(2) Lead tensile strength

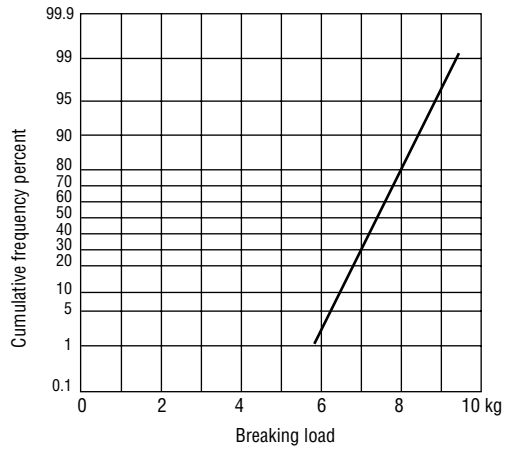

### ENVIRONMENTAL CHARACTERISTICS

(1) Temperature characteristics

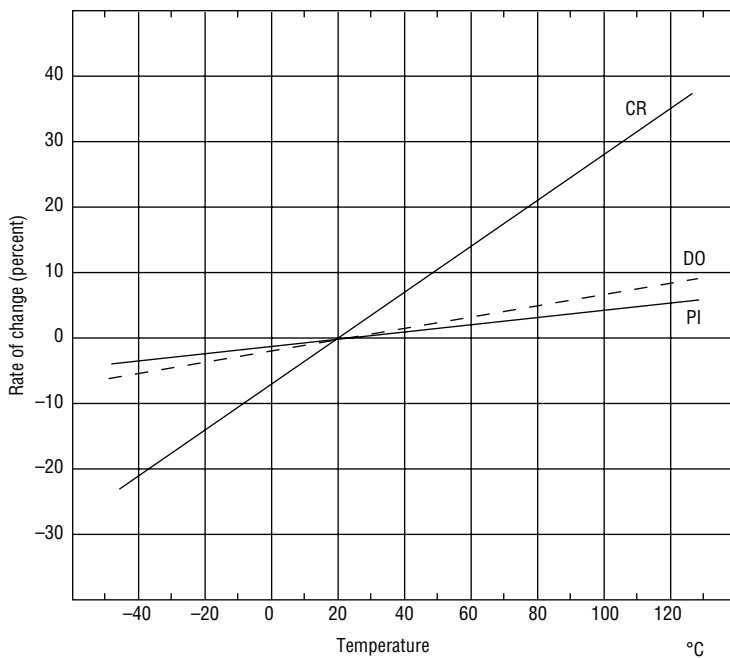

(2) Temperature cycle

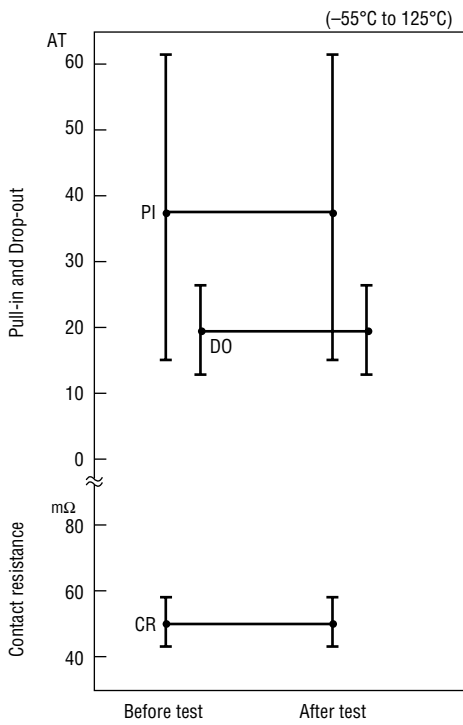

(3) Temperature and humidity cycle

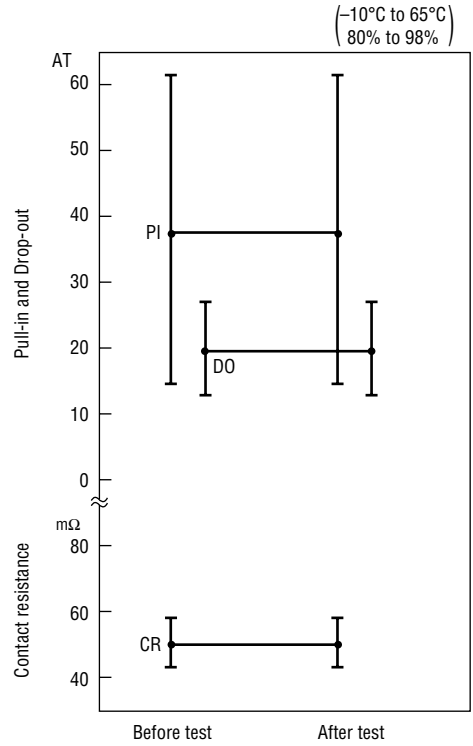

(4) High temperature storage test

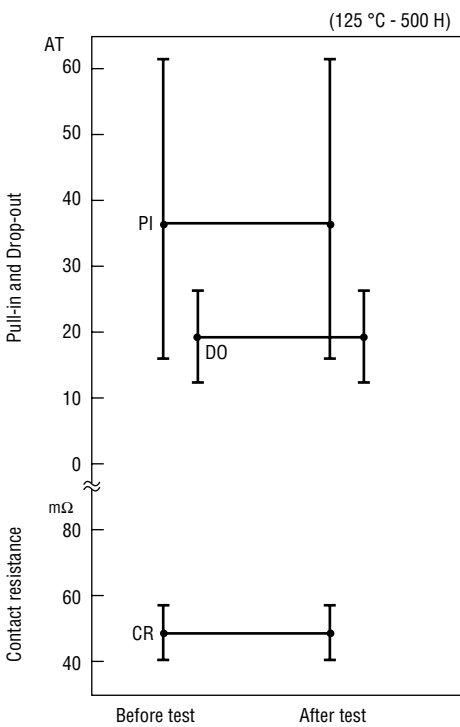

(5) Low temperature storage test

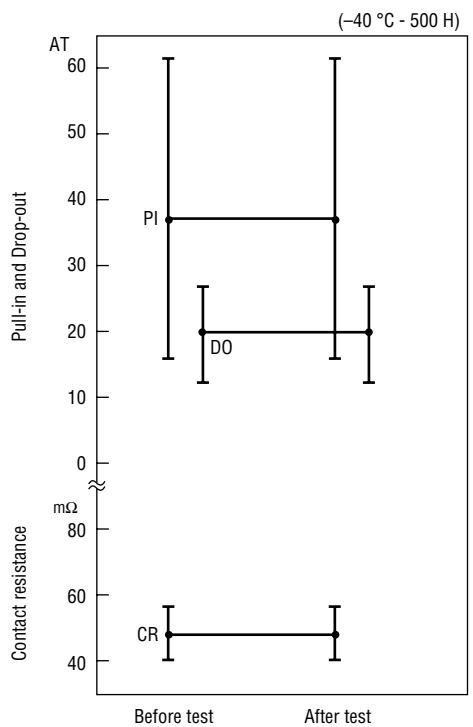

(6) Shock test

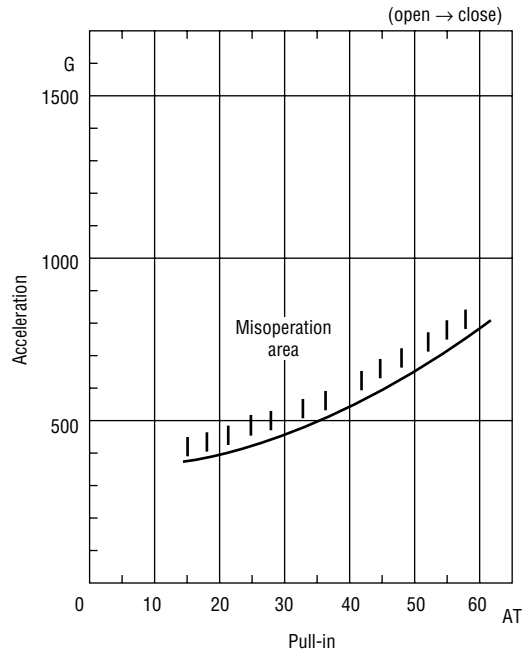
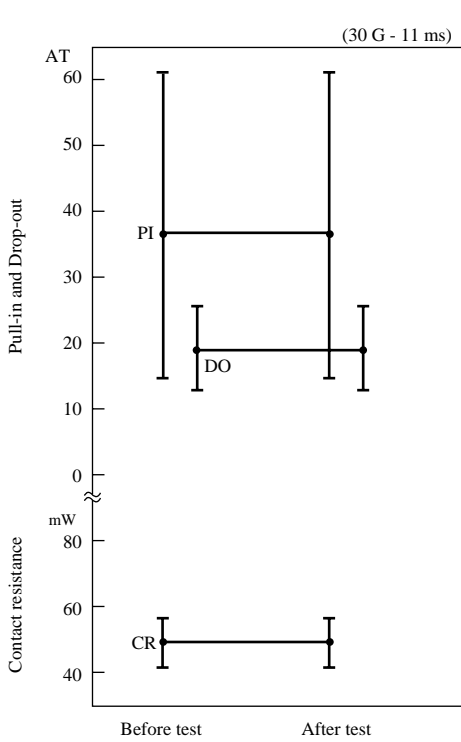

(7) Vibration test

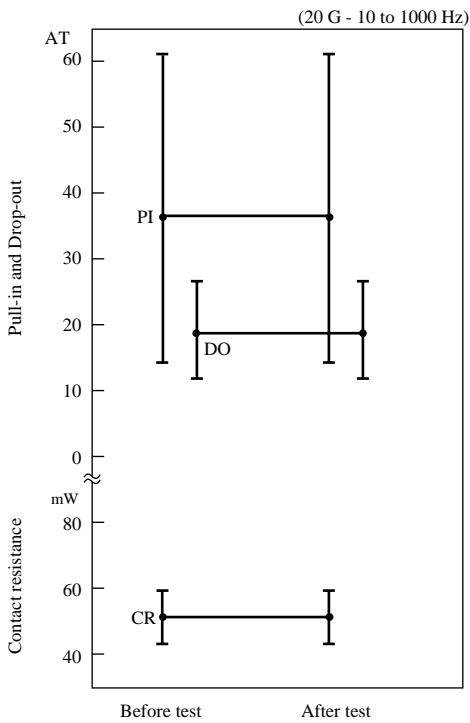



**LIFE EXPECTANCY DATA: ORD2210**

Load conditions

Voltage : 100 VAC  
 Current : 0.7 A, 0.5 A  
 Load : Resistive load

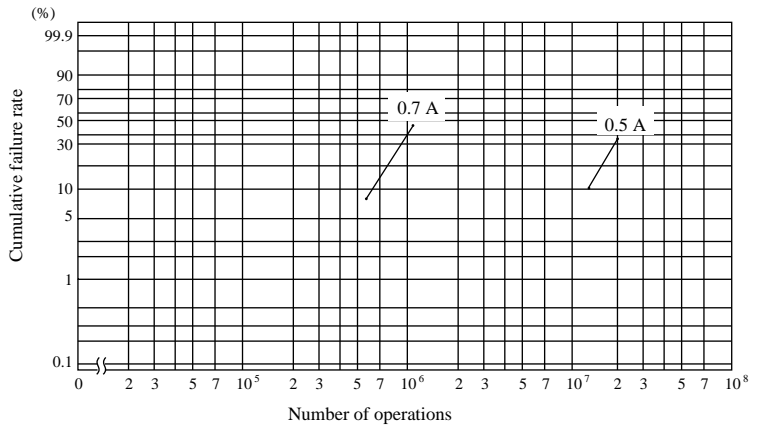

Load conditions

Voltage : 100 VDC, 50 VDC  
 Current : 0.5 A, 1.0 A, 0.5 A  
 Load : Resistive load

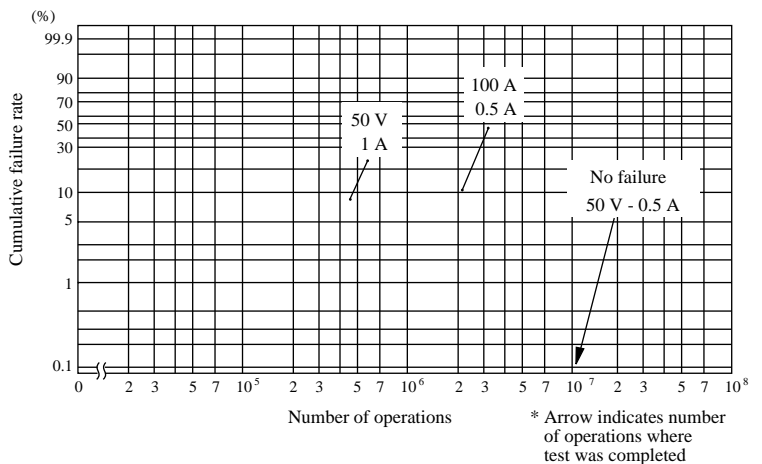

Load conditions

Voltage : 15 VDC  
 Current : 3 mA  
 Load : Resistive load

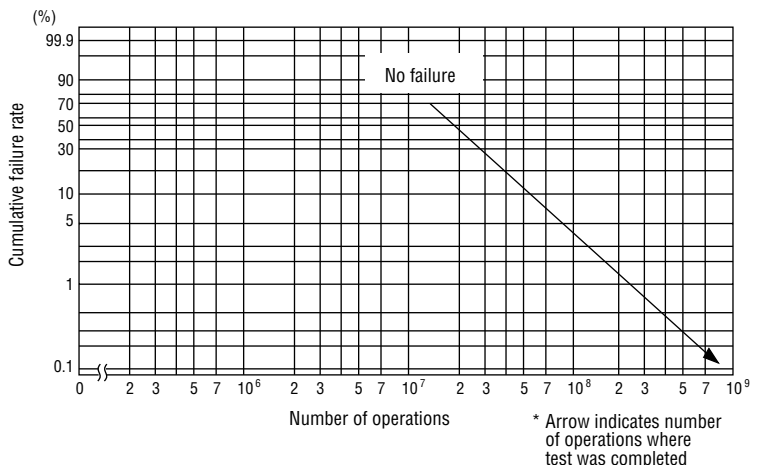

# REED SWITCH

## ORD2210V

### Vacuum Ultra High Breakdown Voltage High Power Reed Switch

#### GENERAL DESCRIPTION

The ORD2210V is a small single-contact reed switch of a vacuum type designed for ultra high breakdown voltages 1000 V DC between the reed contacts.

#### Features

- (1) The reed contacts are hermetically sealed within a glass tube and do not receive any influence from the external atmospheric environment.
- (2) Quick response
- (3) The operating system and electrical circuits are coaxially composed and the ORD2210V is suited to the applications for high frequency transmission.
- (4) Reed switches are compact and light weight.
- (5) Superior corrosion resistance and wear resistance of the contacts assures stable switching operation and long life.
- (6) With a permanent magnet installed, reed switches economically and easily become proximity switches.

#### External Dimensions (Unit:mm)

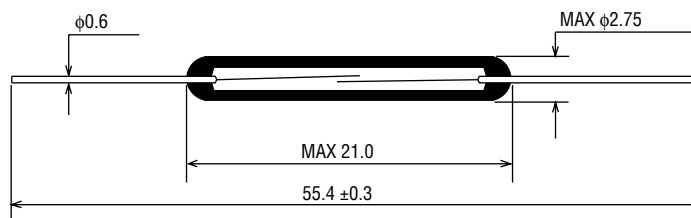

#### APPLICATIONS OF REED SWITCHES

1. Automotive electronic devices
2. Control equipment
3. Communication equipment
4. Measurement equipment
5. Household appliances

**ELECTRICAL CHARACTERISTICS**

Parameter	Symbol	Condition	Rated Value			Unit
			Min.	Typ.	Max.	
Pull-in Value	PI	—	20	—	60	AT
Drop-out Value	DO	—	7	—	—	AT
Contact Resistance	CR	—	—	—	100	mΩ
Breakdown Voltage	—	—	1000	—	—	VDC
Insulation Resistance	—	—	10 <sup>10</sup>	—	—	Ω
Electrostatic Capacitance	—	—	—	—	0.5	pF
Contact Rating	—	—	—	—	100	VA
Maximum Switching Voltage	—	—	—	—	350 DC	V
Maximum Switching Voltage	—	—	—	—	300 AC	V
Maximum Switching Current	—	—	—	—	1.0	A
Maximum Carry Current	—	—	—	—	2.5	A

(1) Drop-out vs. Pull-in

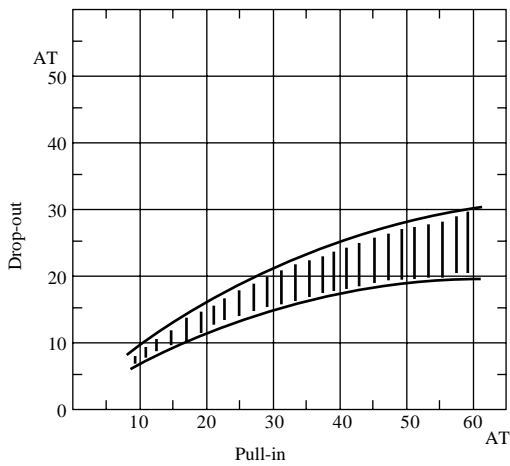

(2) Contact resistance

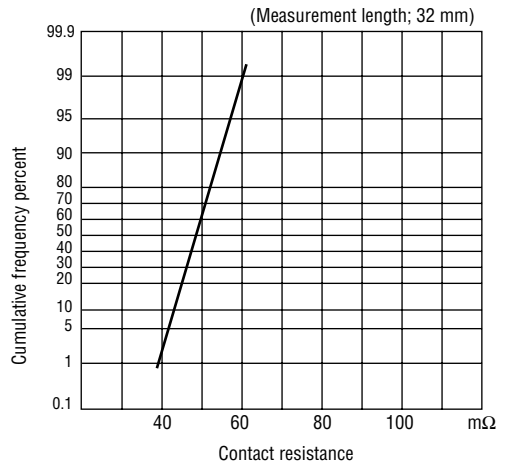

(3) Breakdown voltage

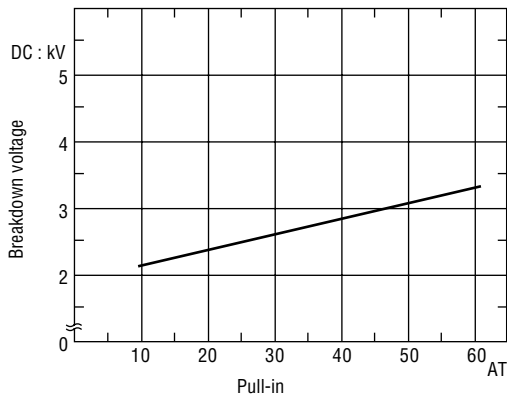

(4) Insulation resistance

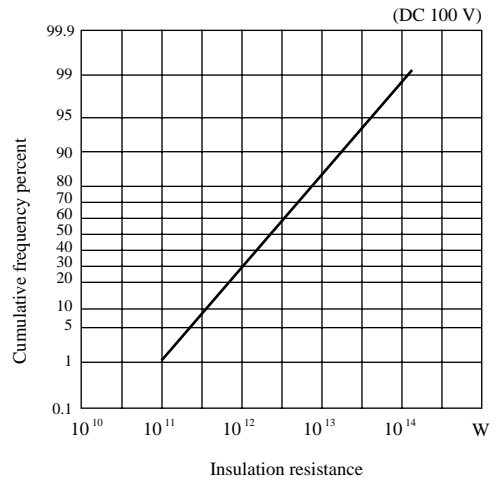

(5) Electrostatic capacitance

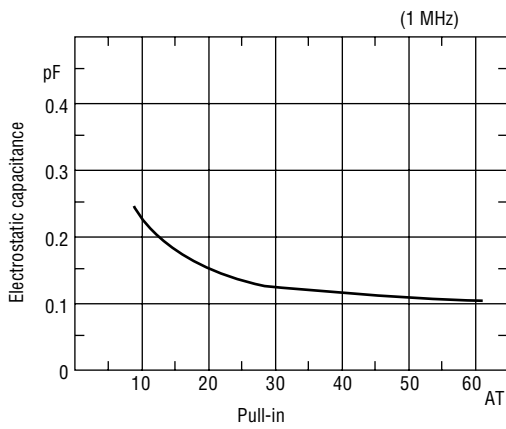

**OPERATING CHARACTERISTICS**

Parameter	Rated Value			Unit
	Min.	Typ.	Max.	
Operate Time	—	—	0.6	ms
Bounce Time	—	—	0.5	ms
Release Time	—	—	0.05	ms
Resonant Frequency	2250	2500	2750	Hz
Maximum Operating Frequency	—	—	500	Hz

(1) Operate time

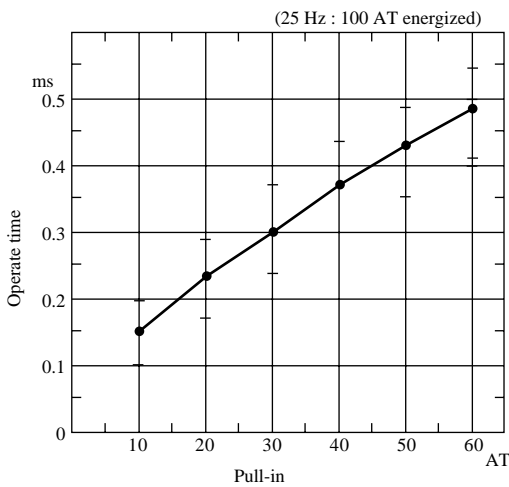

(2) Bounce time

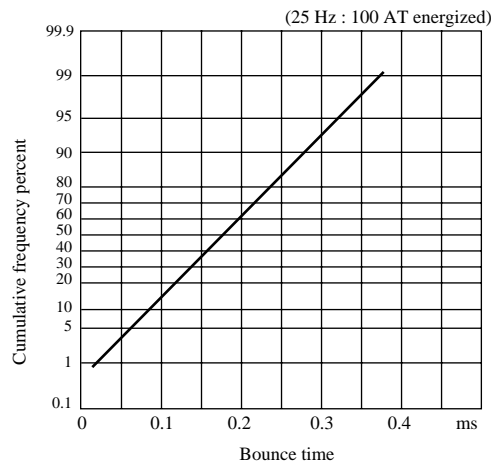

(3) Release time

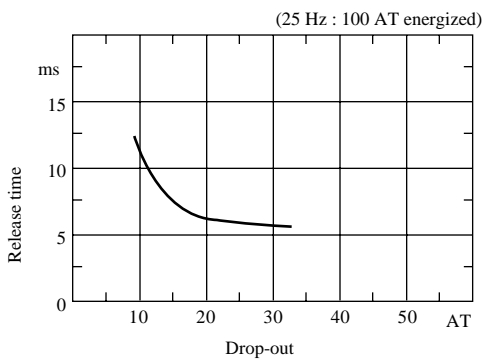

(4) Resonant frequency

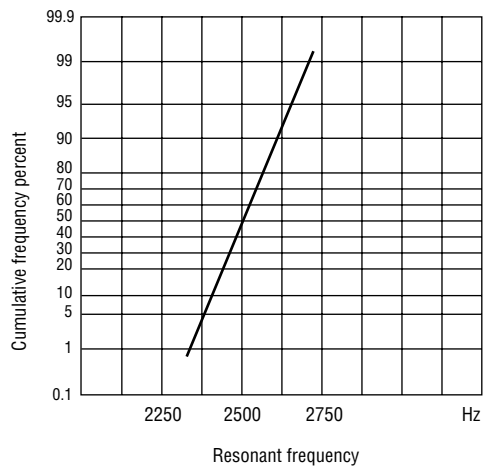

**MECHANICAL CHARACTERISTICS**

(1) Lead tensile test (static load)

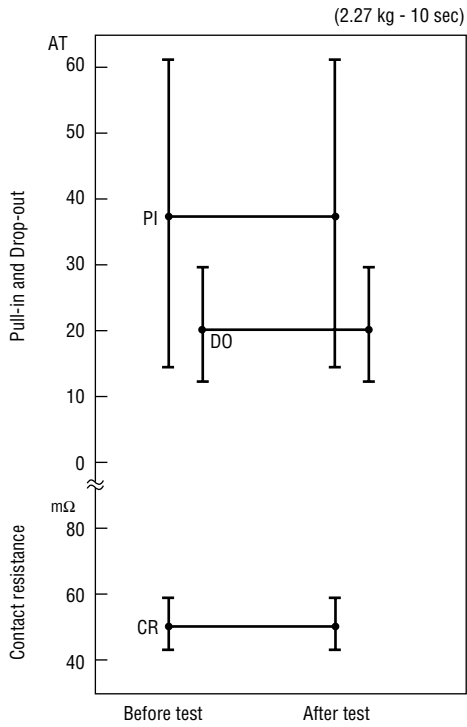

(2) Lead tensile strength

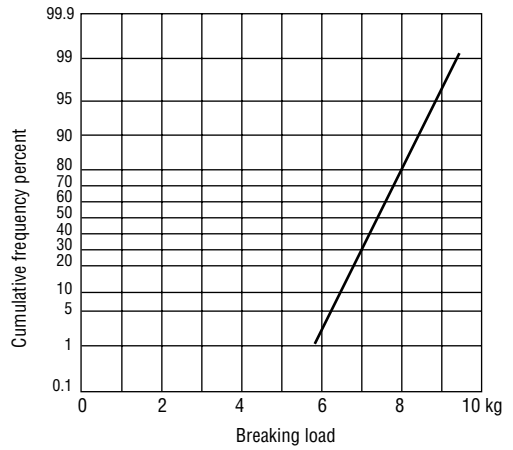

**ENVIRONMENTAL CHARACTERISTICS**

(1) Temperature characteristics

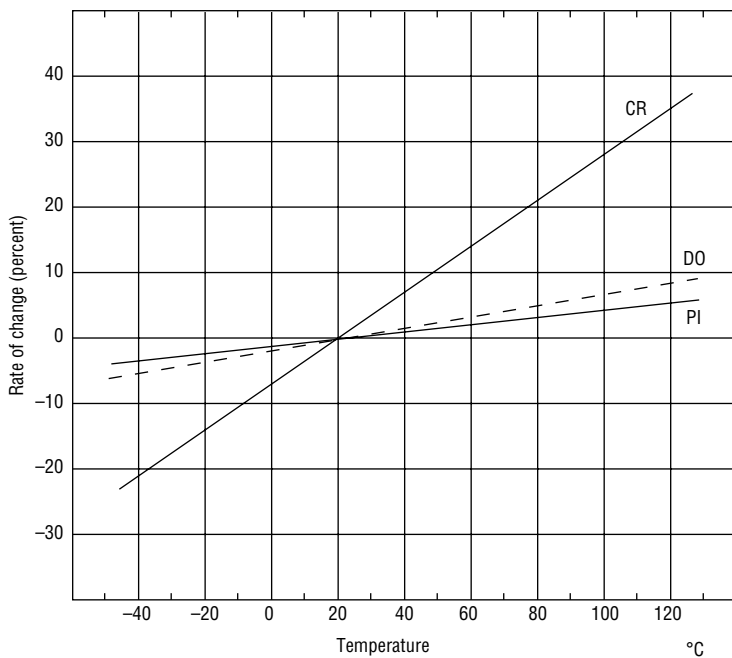

(2) Temperature cycle

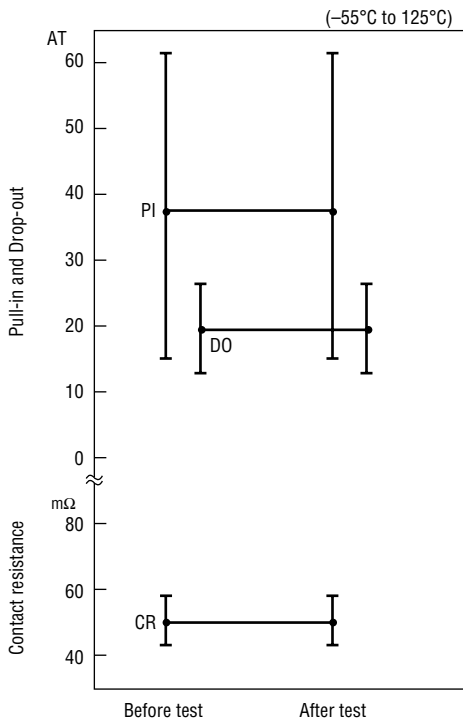

(3) Temperature and humidity cycle

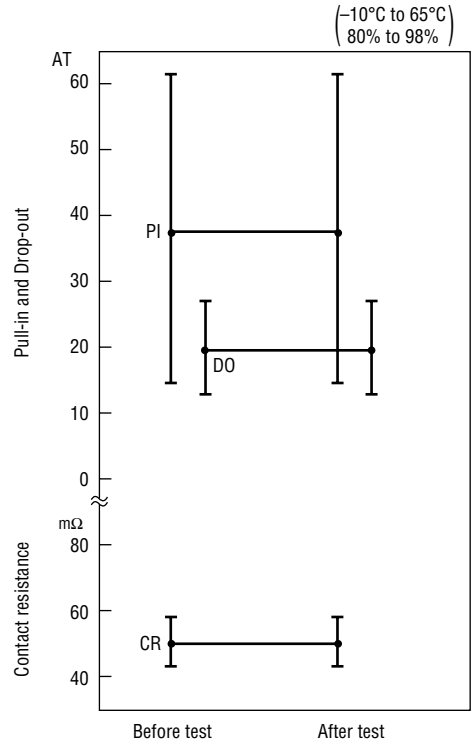

(4) High temperature storage test

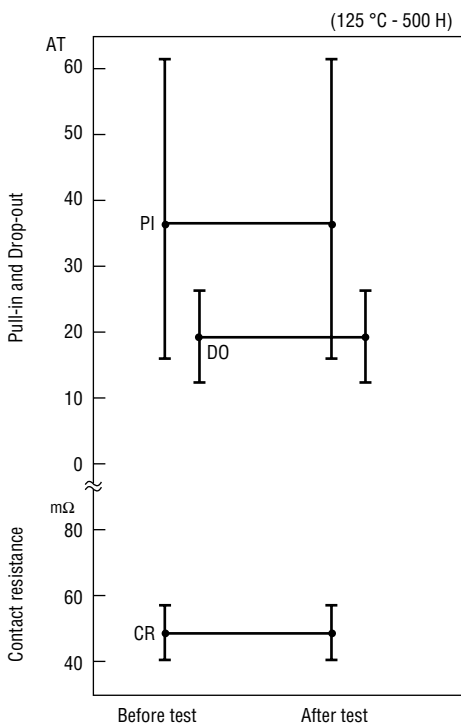

(5) Low temperature storage test

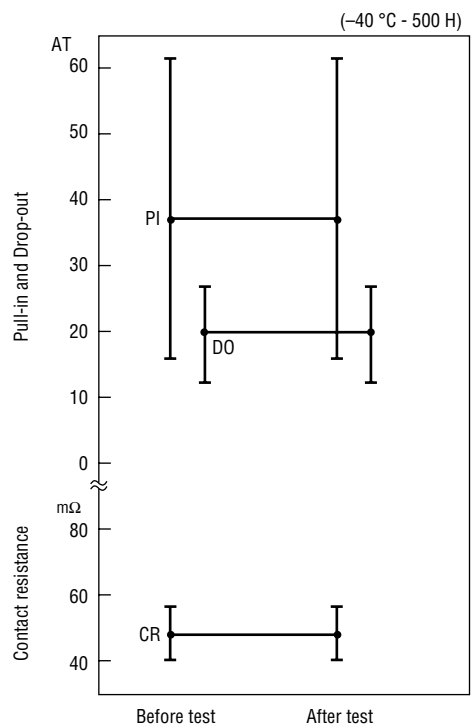

(6) Shock test

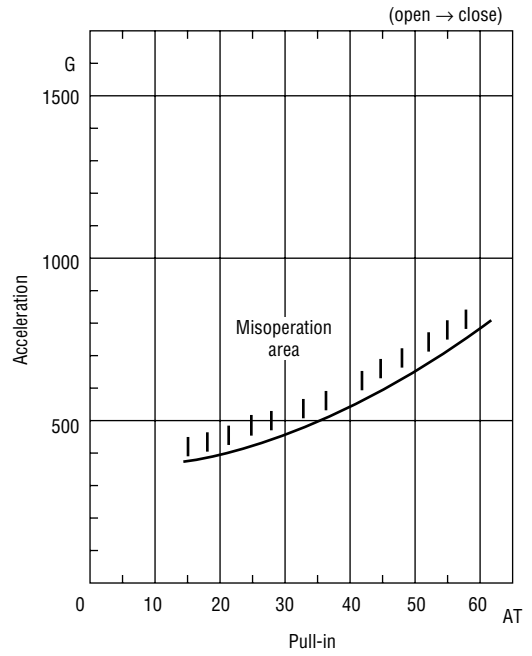
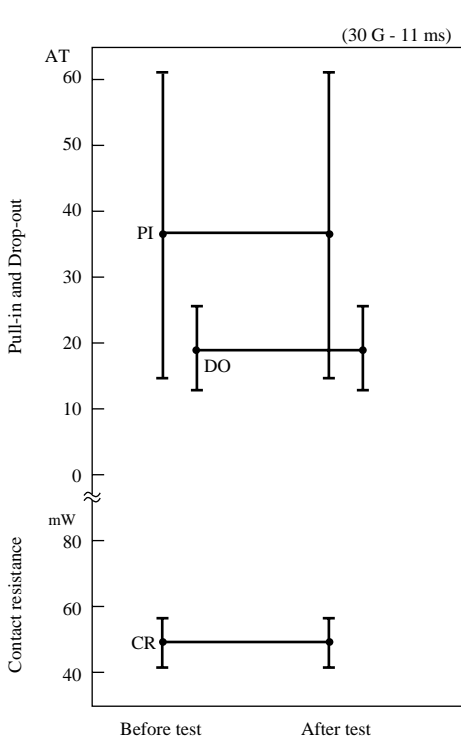

(7) Vibration test

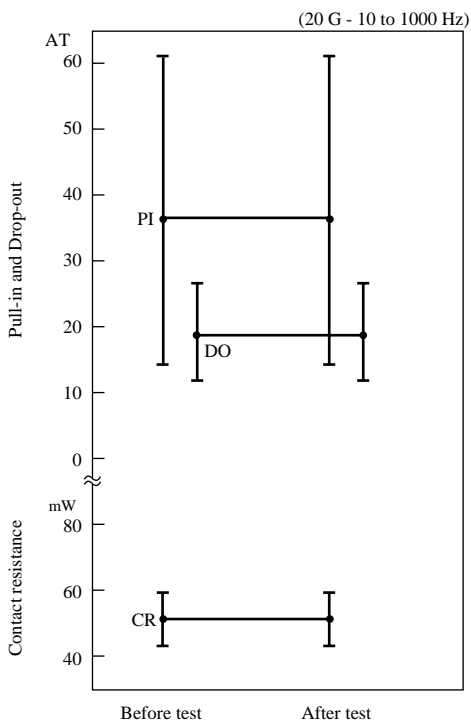



**LIFE EXPECTANCY DATA: ORD2210V**

Load conditions

Voltage : 200 VDC  
 Current : 1 mA  
 Load : Resistive load

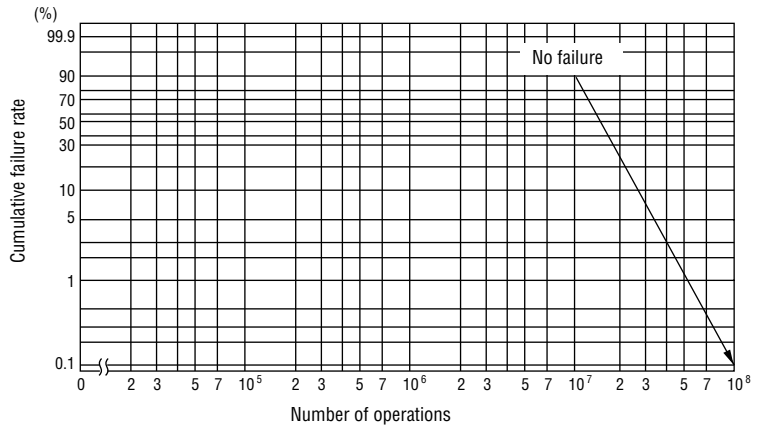

Load conditions

Voltage : 500 VDC  
 Current : 1 mA  
 Load : Resistive load

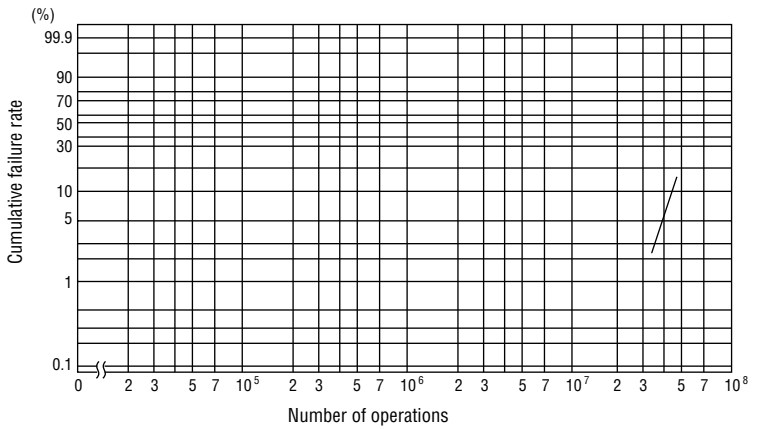

Load conditions

Voltage : 1 kVDC  
 Current : 1 mA  
 Load : Resistive load

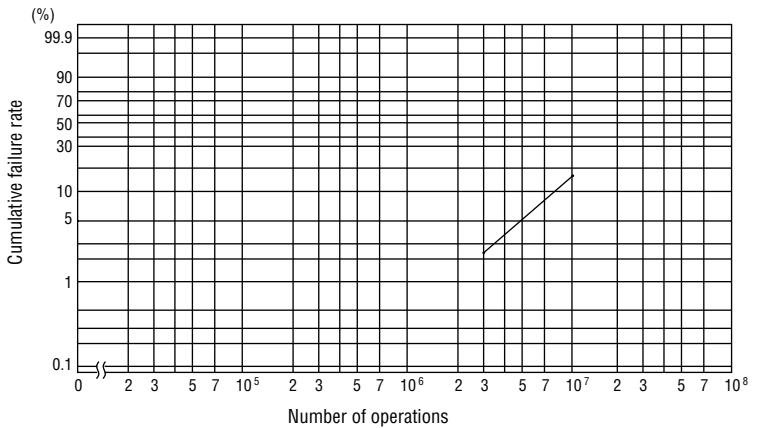

# REED SWITCH

## ORD234

**Long Life (More than 100 million operations)**

### GENERAL DESCRIPTION

The ORD234 is a single-contact reed switch designed for long life for increased number of operations. The contacts are sealed within the glass tube with inert gas to maintain contact reliability.

### Features

- (1) Reed contacts are hermetically sealed within a glass tube with inert gas and do not receive any influence from the external atmospheric environment.
- (2) Quick response
- (3) The structure comprises an operating system and electrical circuits coaxially. Reed switches are suited to applications in radio frequency.
- (4) Reed switches are compact and light weight.
- (5) Superior corrosion resistance and wear resistance of the contacts assures stable switching operation and long life.
- (6) With a permanent magnet installed, reed switches economically and easily become proximity switches.

### External Dimensions (Unit:mm)

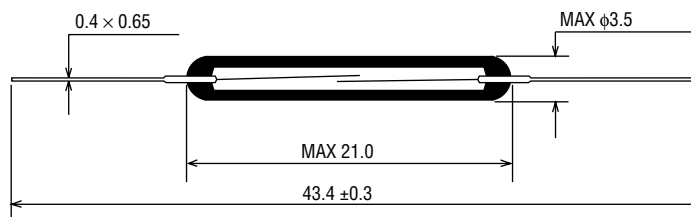

### APPLICATIONS OF REED SWITCHES

1. Automotive electronic devices
2. Control equipment
3. Communication equipment
4. Measurement equipment
5. Household appliances

**ELECTRICAL CHARACTERISTICS**

Parameter	Symbol	Condition	Rated Value			Unit
			Min.	Typ.	Max.	
Pull-in Value	PI	—	15	—	50	AT
Drop-out Value	DO	—	6	—	—	AT
Contact Resistance	CR	—	—	—	100	mΩ
Breakdown Voltage	—	PI>20	250	—	—	VDC
Breakdown Voltage	—	PI<20	200	—	—	VDC
Insulation Resistance	—	—	10 <sup>10</sup>	—	—	Ω
Electrostatic Capacitance	—	—	—	—	0.5	pF
Contact Rating	—	—	—	—	10	VA
Maximum Switching Voltage	—	—	—	—	200 DC	V
Maximum Switching Voltage	—	—	—	—	100 AC	V
Maximum Switching Current	—	—	—	—	0.5	A
Maximum Carry Current	—	—	—	—	2.0	A

(1) Drop-out vs. Pull-in

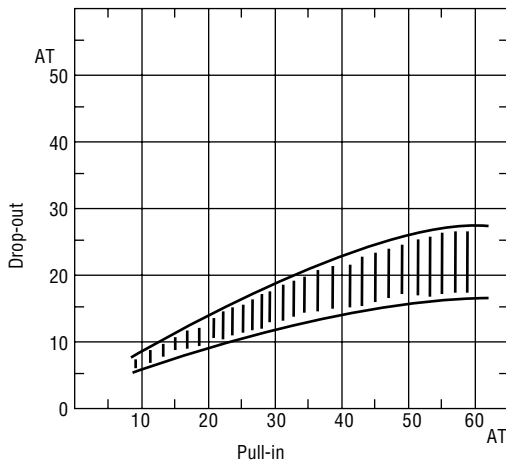

(2) Contact resistance

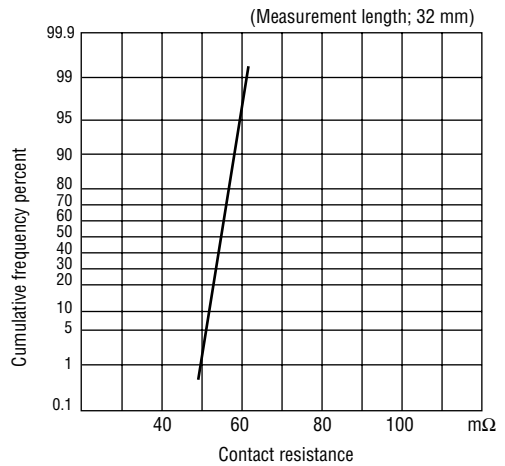

(3) Breakdown voltage

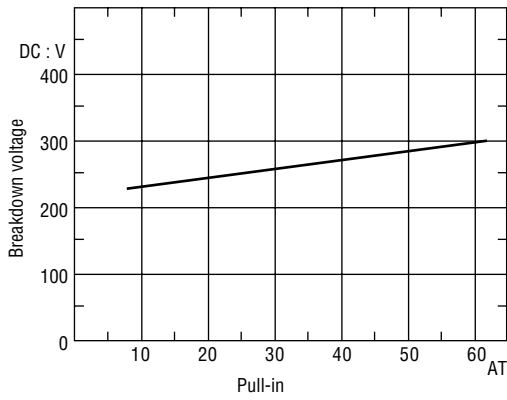

(4) Insulation resistance

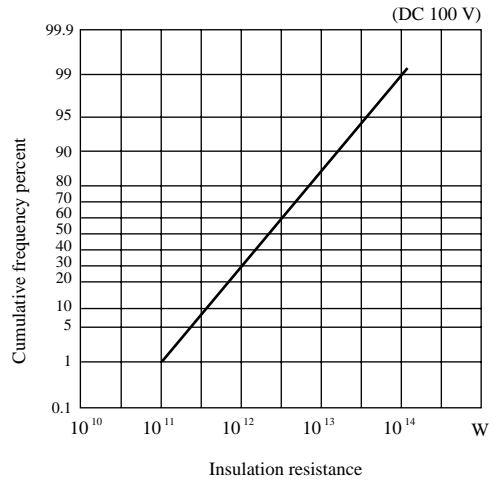

(5) Electrostatic capacitance

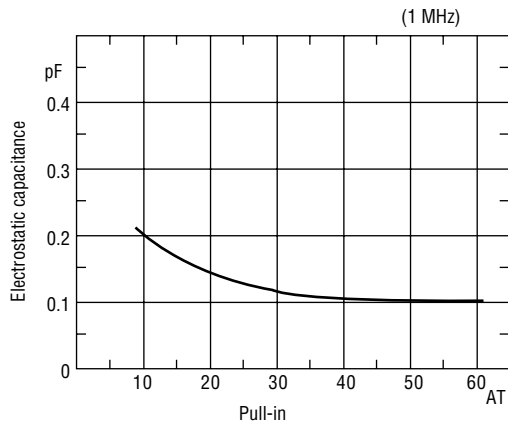

**OPERATING CHARACTERISTICS**

Parameter	Rated Value			Unit
	Min.	Typ.	Max.	
Operate Time	—	—	0.5	ms
Bounce Time	—	—	0.5	ms
Release Time	—	—	0.05	ms
Resonant Frequency	1900	2200	2500	Hz
Maximum Operating Frequency	—	—	500	Hz

(1) Operate time

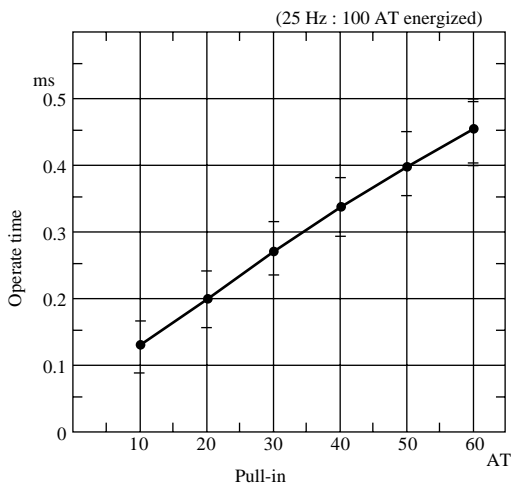

(2) Bounce time

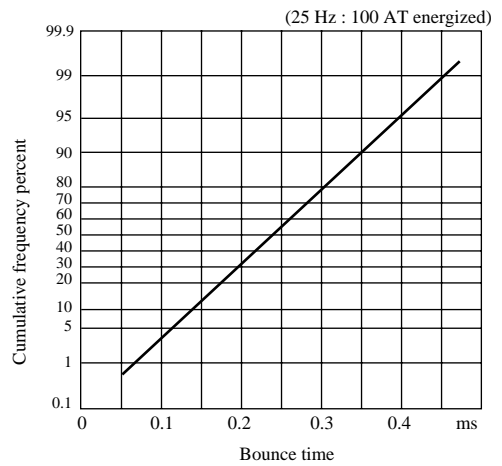

(3) Release time

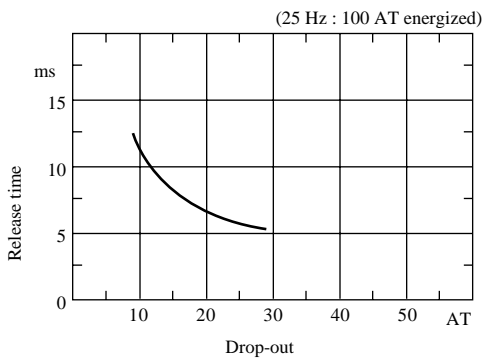

(4) Resonant frequency

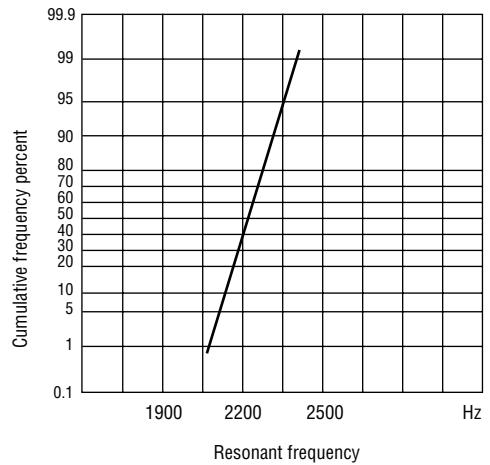

**MECHANICAL CHARACTERISTICS**

(1) Lead tensile test (static load)

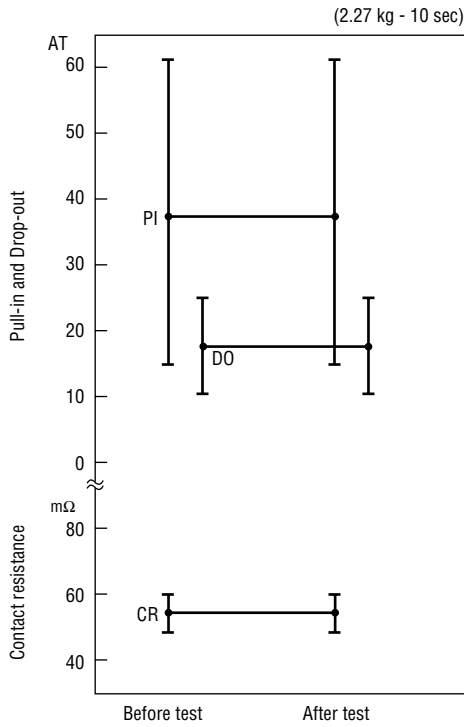

(2) Lead tensile strength

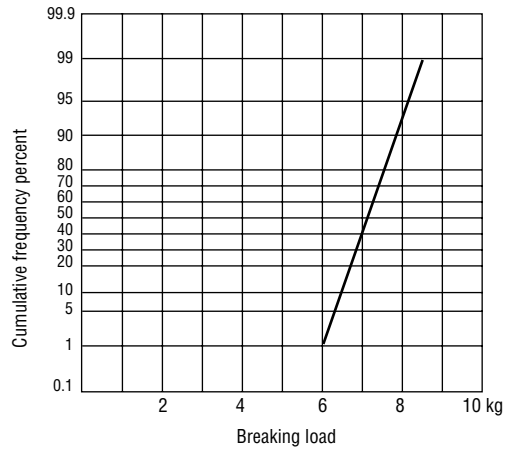

**ENVIRONMENTAL CHARACTERISTICS**

(1) Temperature characteristics

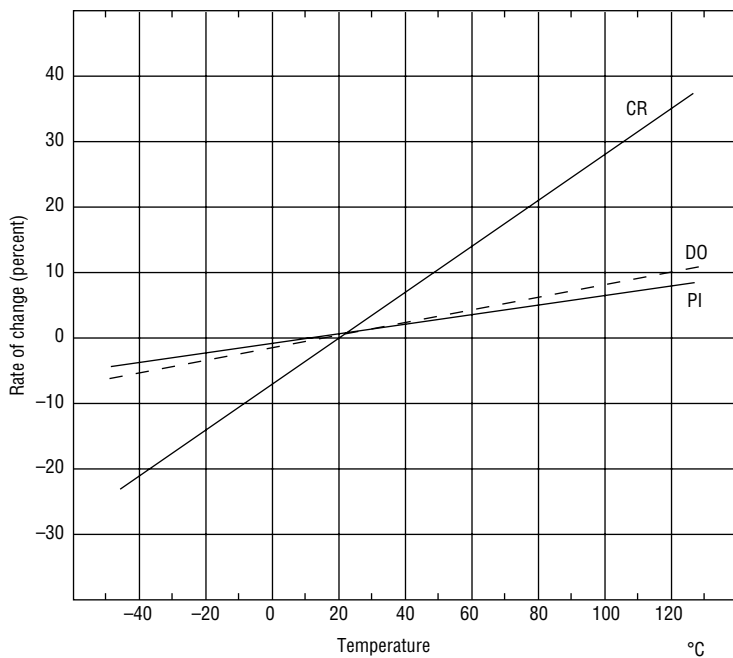

(2) Temperature cycle

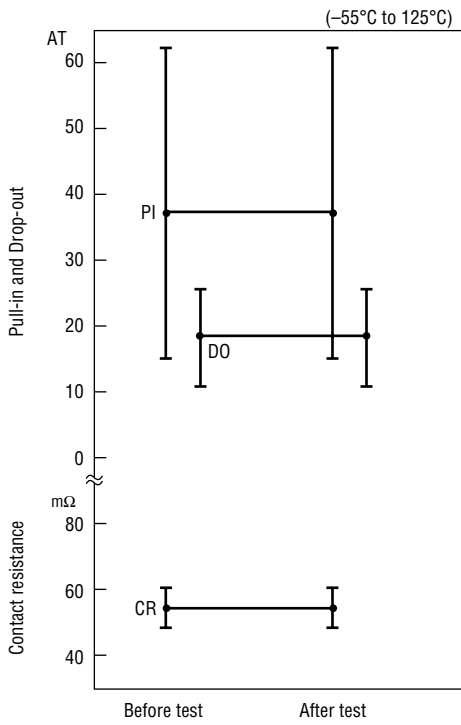

(3) Temperature and humidity cycle

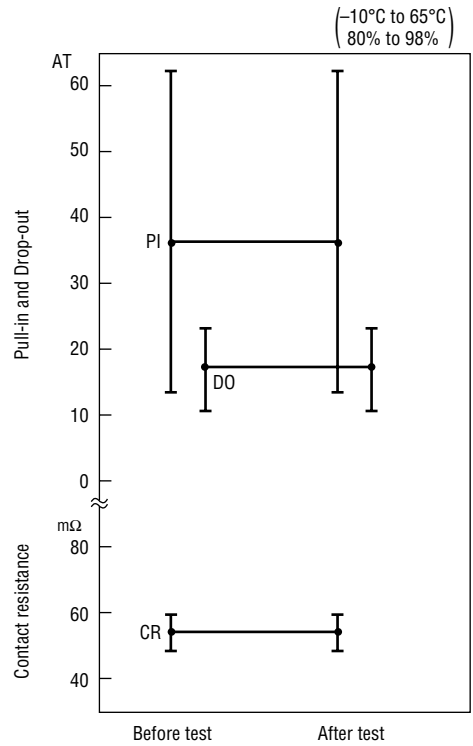

(4) High temperature storage test

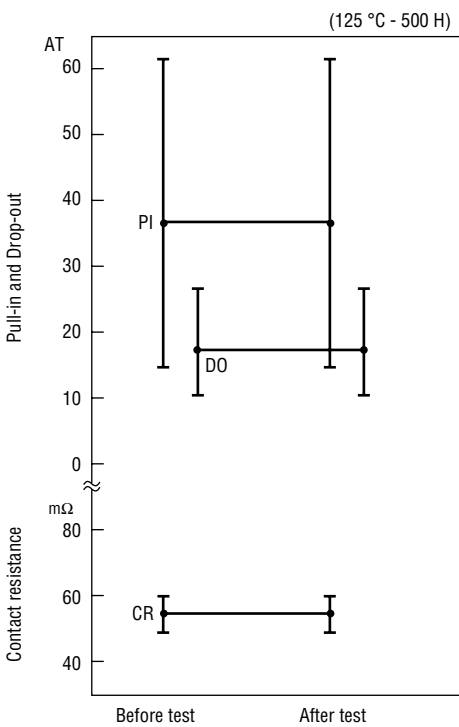

(5) Low temperature storage test

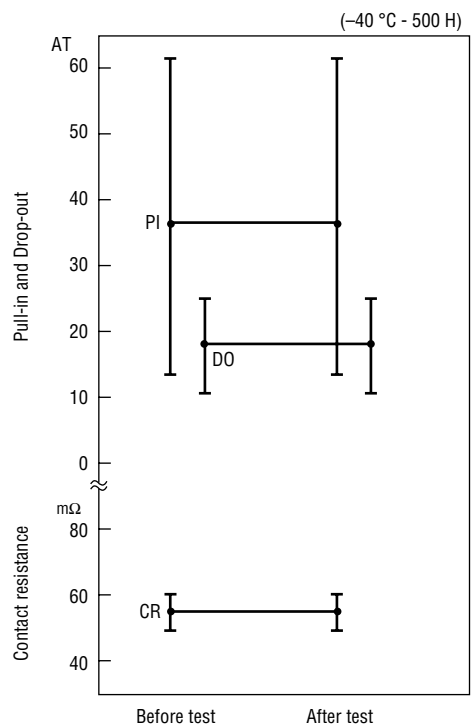

(6) Shock test

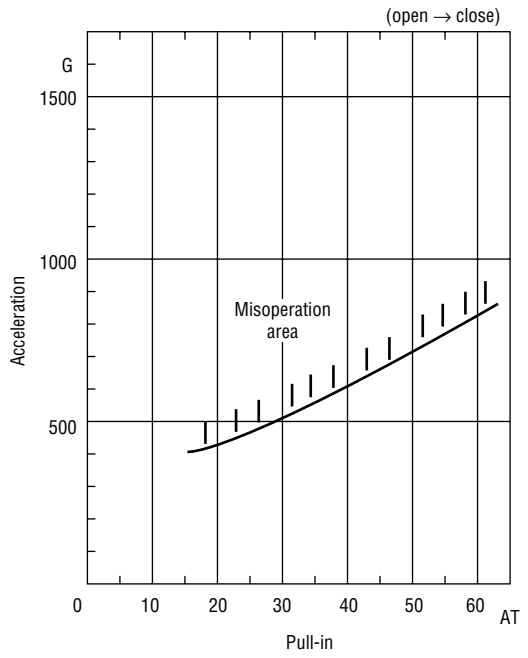
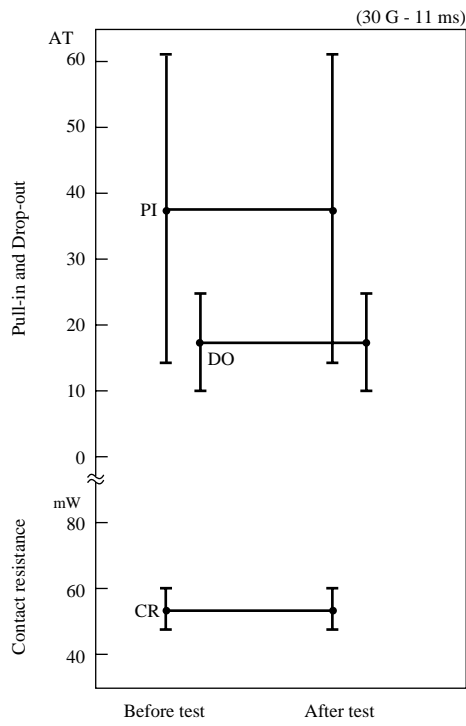

(7) Vibration test

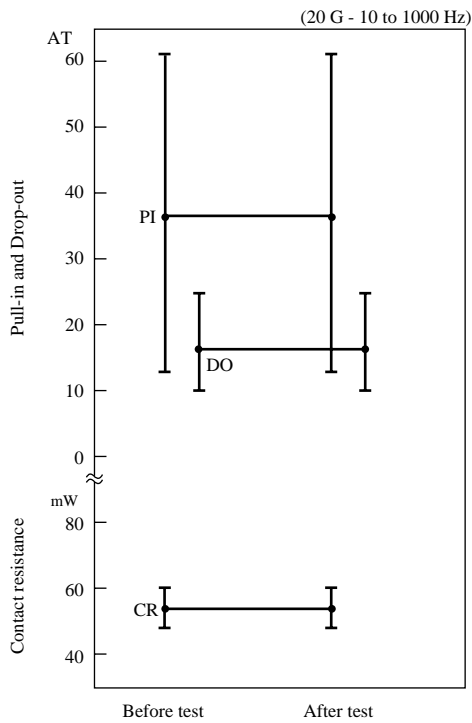



**LIFE EXPECTANCY DATA: ORD234**

Load conditions

Voltage : 5 VDC  
 Current : 100  $\mu$ A, 1 mA, 5 mA  
 Load : Resistive load

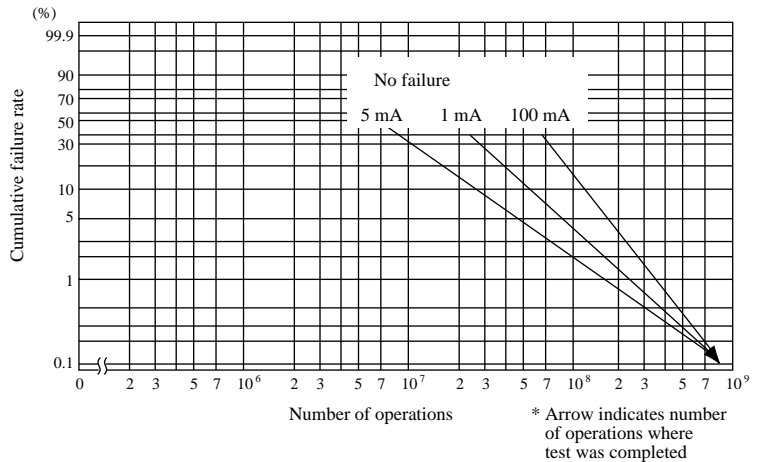

Load conditions

Voltage : 6 VDC, 7 VDC  
 Current : 10 mA, 20 mA, 2.2 mA  
 Load : Resistive load

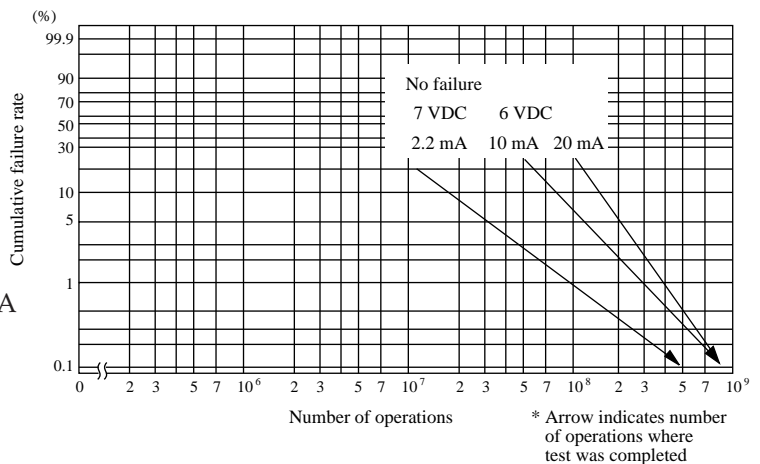

Load conditions

Voltage : 12 VDC, 24 VDC, 48 VDC  
 Current : 10 mA, 250 mA, 400 mA  
 Load : Resistive load

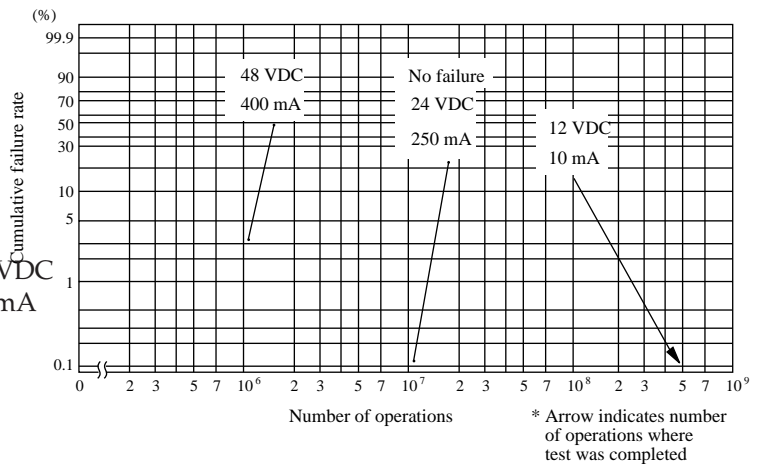

# REED SWITCH

## ORT551

### Ultraminiature Transfer Type

#### GENERAL DESCRIPTION

The ORT551 is a ultraminiature two-contact reed switch designed for transfer type operation. The contacts are sealed within the glass tube with inert gas to maintain contact reliability.

#### Features

- (1) Reed contacts are hermetically sealed within a glass tube with inert gas and do not receive any influence from the external atmospheric environment.
- (2) Quick response
- (3) The structure comprises an operating system and electrical circuits coaxially. Reed switches are suited to applications in radio frequency.
- (4) Reed switches are compact and light weight.
- (5) Superior corrosion resistance and wear resistance of the contacts assures stable switching operation and long life.
- (6) With a permanent magnet installed, reed switches economically and easily become proximity switches.

#### External Dimensions (Unit:mm)

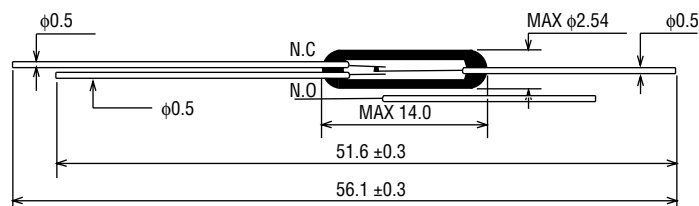

#### APPLICATIONS OF REED SWITCHES

1. Automotive electronic devices
2. Control equipment
3. Communication equipment
4. Measurement equipment
5. Household appliances

**ELECTRICAL CHARACTERISTICS**

Parameter	Symbol	Condition	Rated Value			Unit
			Min.	Typ.	Max.	
Pull-in Value	PI	—	10	—	25	AT
Drop-out Value	DO	—	4	—	—	AT
Contact Resistance	CR	—	—	—	100	mΩ
Breakdown Voltage	—	PI>20	200	—	—	VDC
Breakdown Voltage	—	PI<20	150	—	—	VDC
Insulation Resistance	—	—	10 <sup>9</sup>	—	—	Ω
Electrostatic Capacitance	—	—	—	—	1.5	pF
Contact Rating	—	—	—	—	3	VA
Maximum Switching Voltage	—	—	—	—	30 <sup>DC</sup> <sub>AC</sub>	V
Maximum Switching Current	—	—	—	—	0.2	A
Maximum Carry Current	—	—	—	—	0.5	A

(1) Drop-out vs. Pull-in

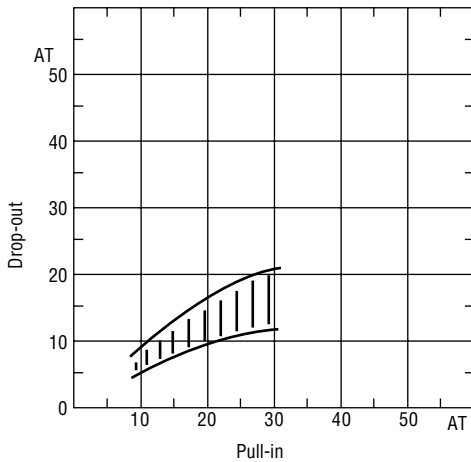

(2) Contact resistance

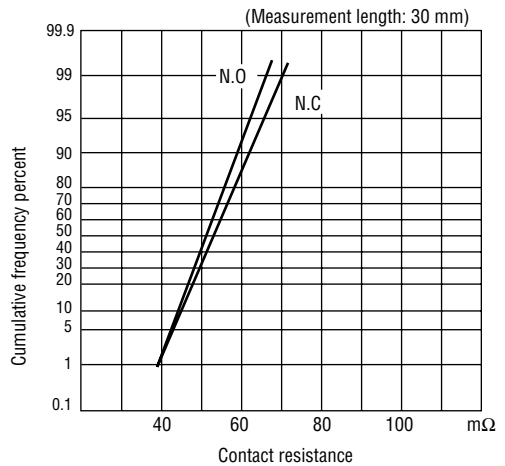

(3) Breakdown voltage

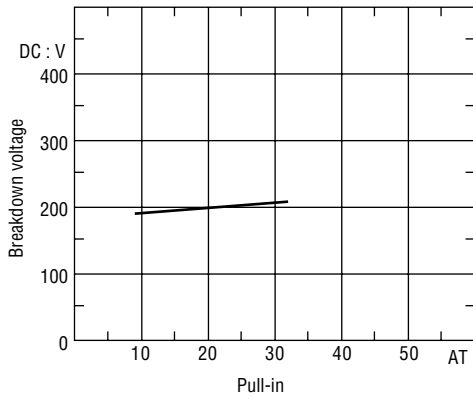

(4) Insulation resistance

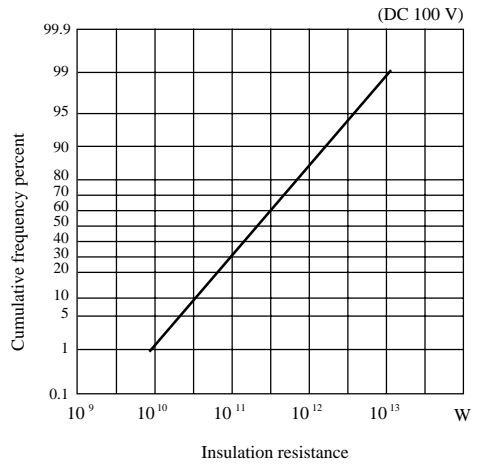

(5) Electrostatic capacitance

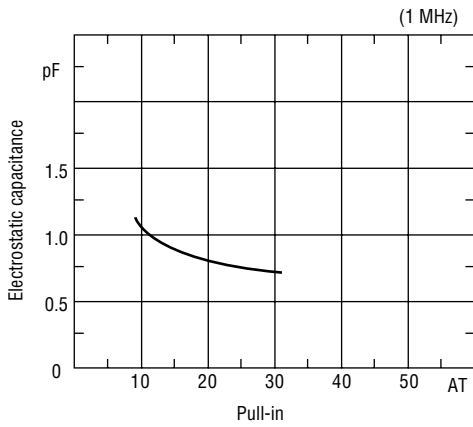

**OPERATING CHARACTERISTICS**

Parameter	Rated Value			Unit
	Min.	Typ.	Max.	
Operate Time	—	—	1.0	ms
Bounce Time	—	—	N.O 1.0	ms
Bounce Time	—	—	N.C 1.5	ms
Release Time	—	—	0.5	ms
Resonant Frequency	2000	6000	10000	Hz
Maximum Operating Frequency	—	—	200	Hz

(1) Operate time

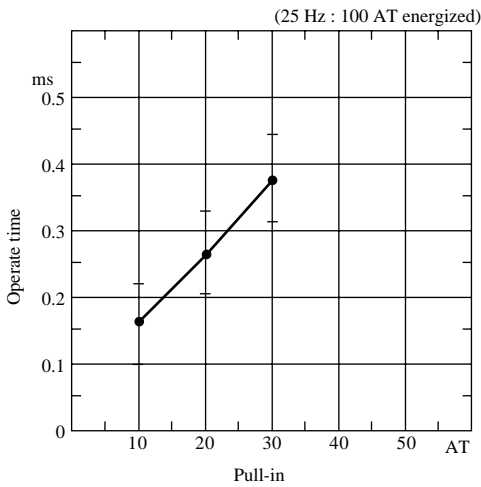

(2) Bounce time

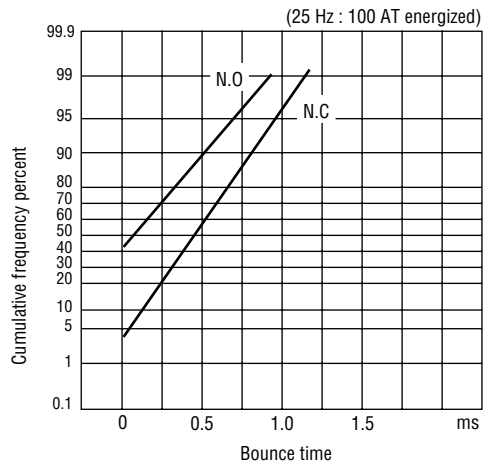

(3) Release time

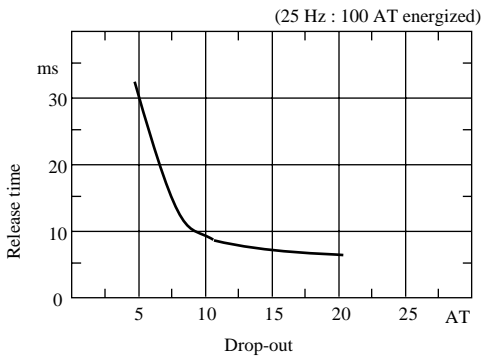

(4) Resonant frequency

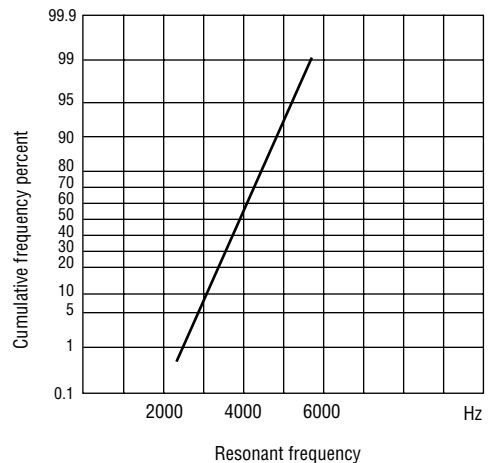

**MECHANICAL CHARACTERISTICS**

(1) Lead tensile test (static load)

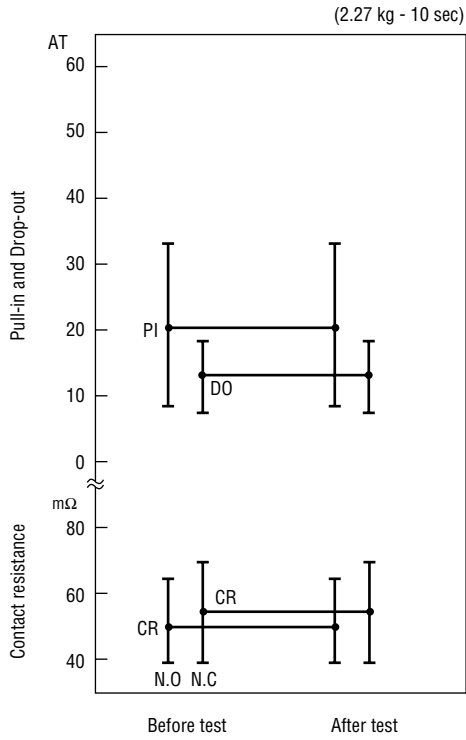

(2) Lead tensile strength

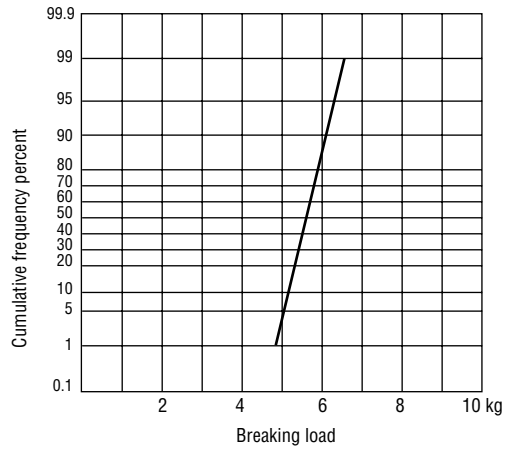

**ENVIRONMENTAL CHARACTERISTICS**

(1) Temperature characteristics

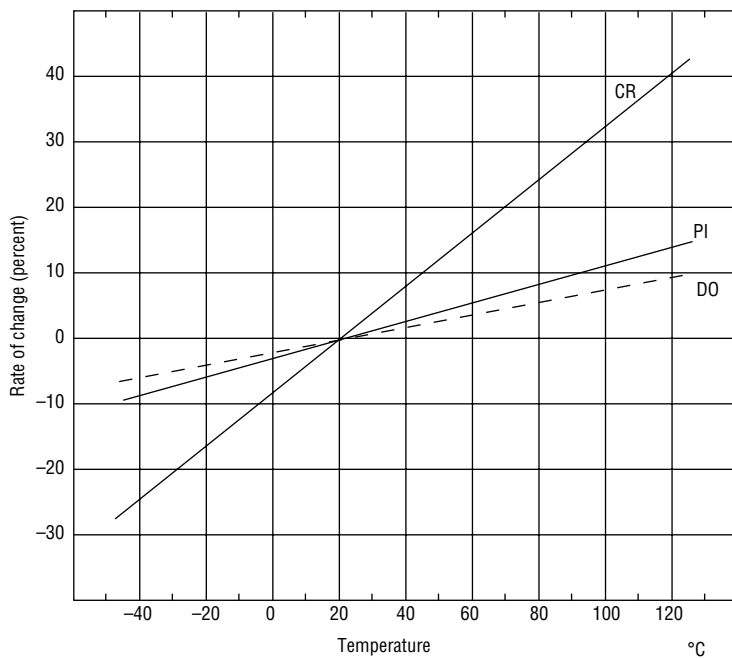

(2) Temperature cycle

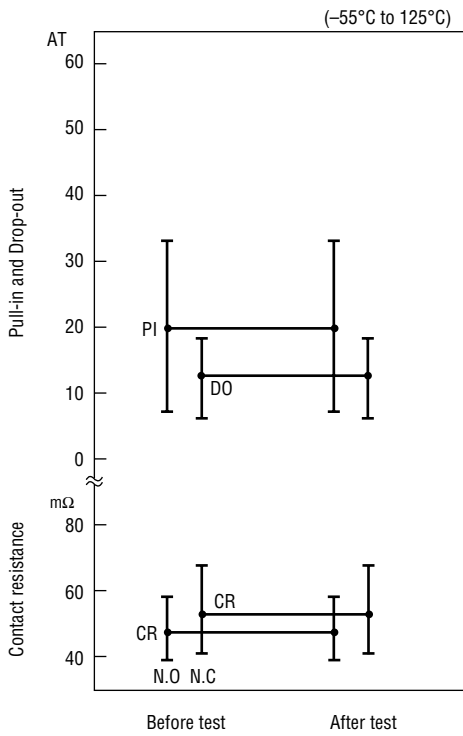

(3) Temperature and humidity cycle

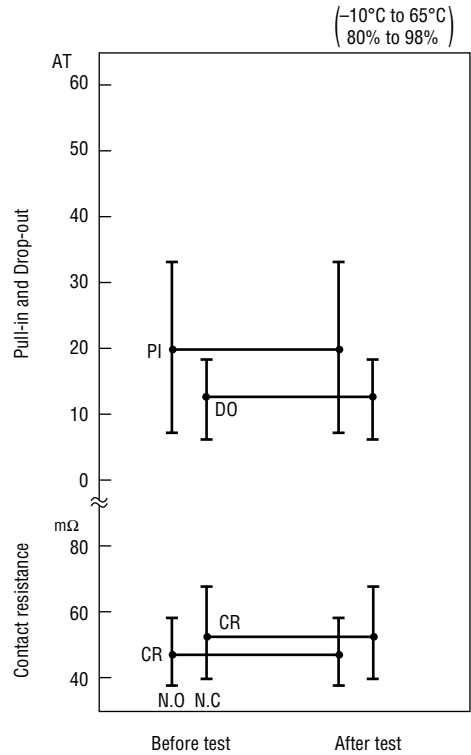

(4) High temperature storage test

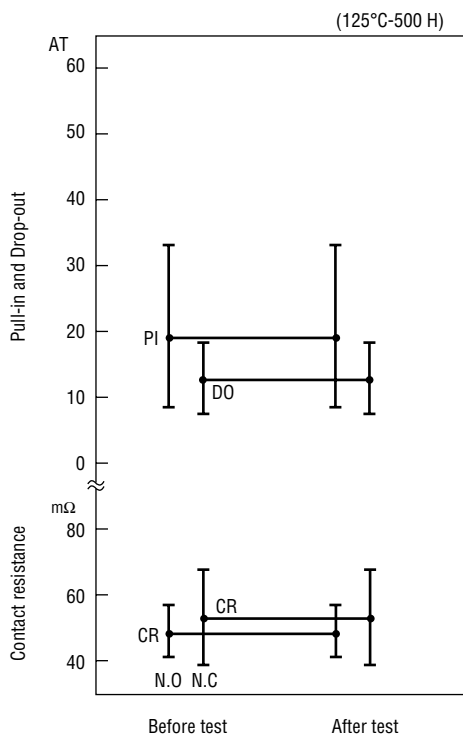

(5) Low temperature storage test

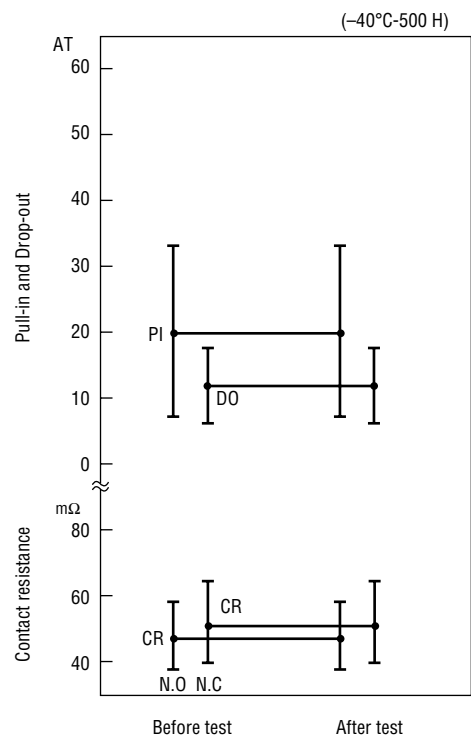

(6) Shock test

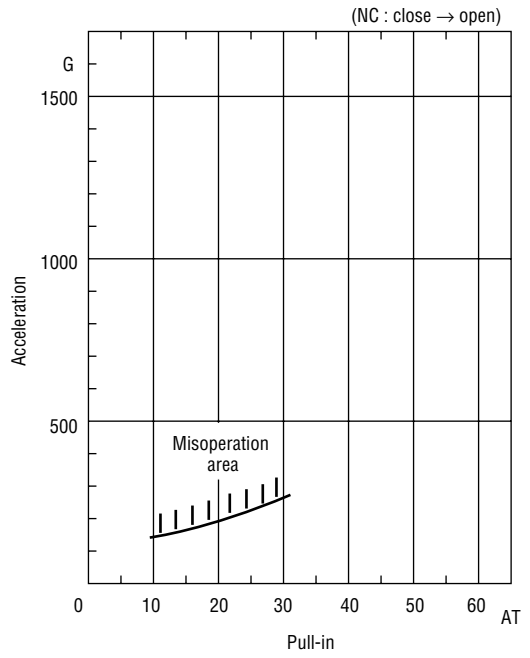
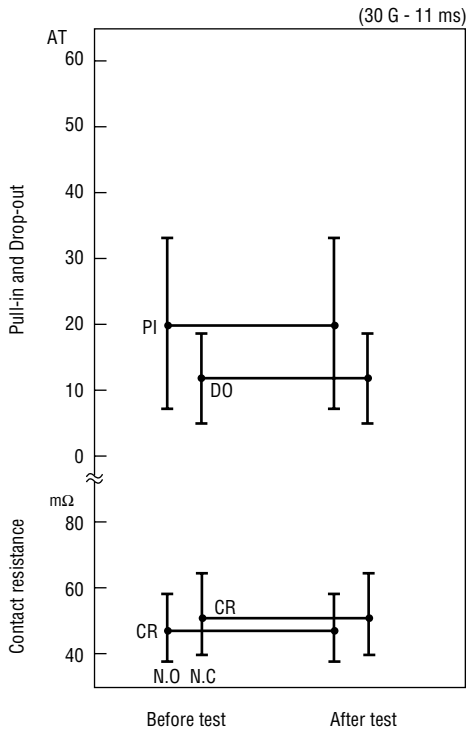

(7) Vibration test

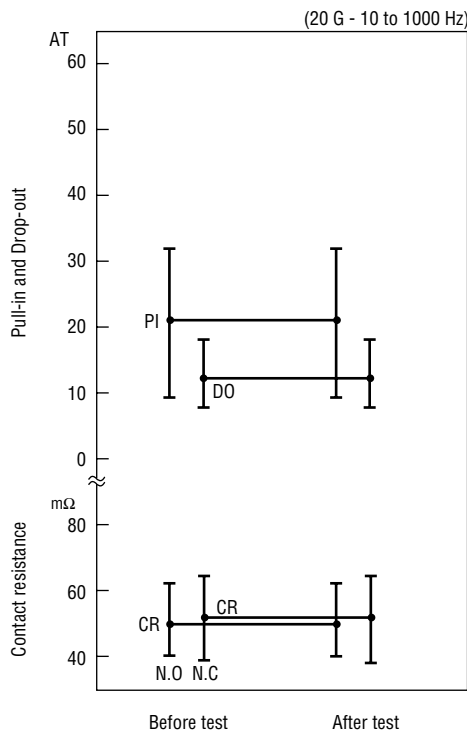



**LIFE EXPECTANCY DATA: ORT551**

Load conditions

Voltage : 5 VDC  
 Current : 100  $\mu$ A, 1 mA, 5 mA  
 Load : Resistive load

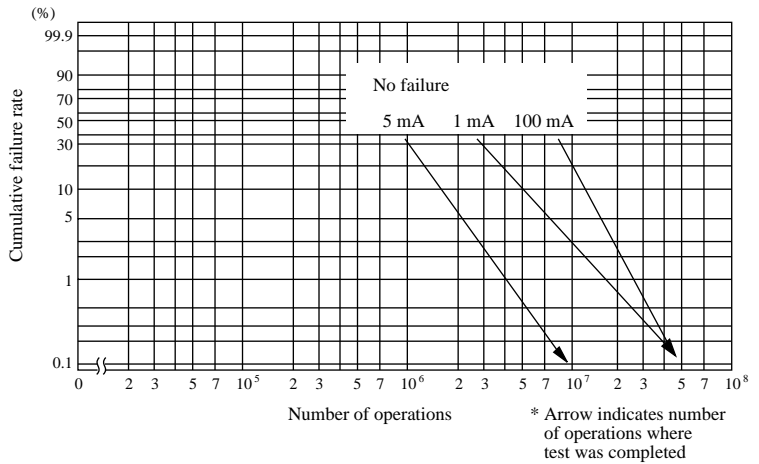

Load conditions

Voltage : 12 VDC  
 Current : 5 mA, 10 mA, 100 mA  
 Load : Resistive load

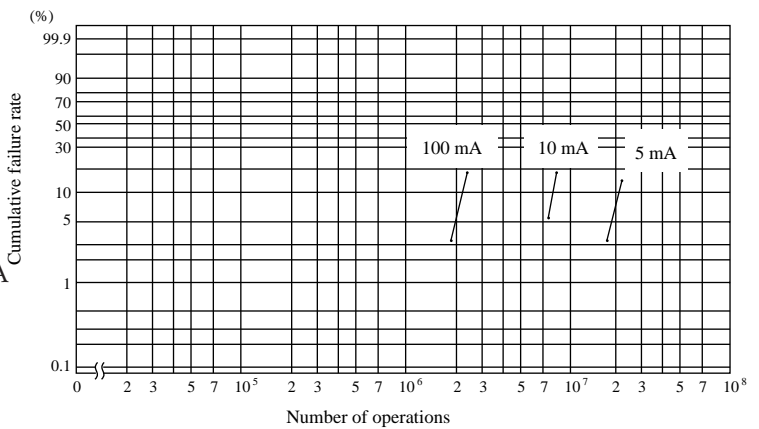

Load conditions

Voltage : 24 VDC  
 Current : 50 mA, 100 mA  
 Load : Resistive load

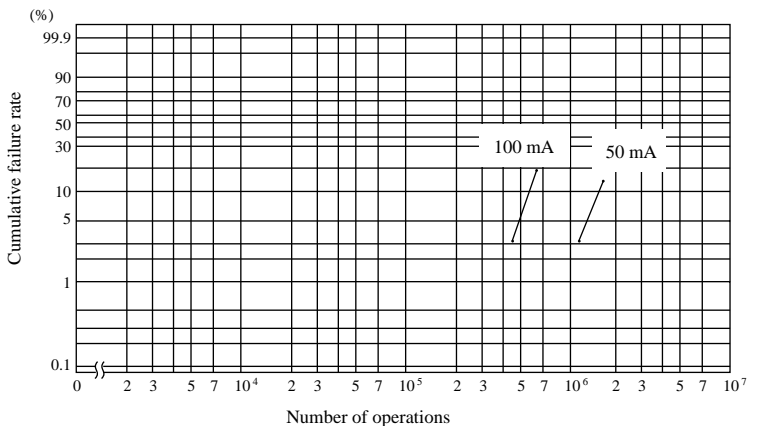

# REED SWITCH

## ORT233

### Miniature Transfer Type

#### GENERAL DESCRIPTION

The ORT233 is a miniature two-contact reed switch designed for transfer type operation. The contacts are sealed within the glass tube with inert gas to maintain contact reliability.

#### Features

- (1) Reed contacts are hermetically sealed within a glass tube with inert gas and do not receive any influence from the external atmospheric environment.
- (2) Quick response
- (3) The structure comprises an operating system and electrical circuits coaxially. Reed switches are suited to applications in radio frequency.
- (4) Reed switches are compact and light weight.
- (5) Superior corrosion resistance and wear resistance of the contacts assures stable switching operation and long life.
- (6) With a permanent magnet installed, reed switches economically and easily become proximity switches.

#### External Dimensions (Unit:mm)

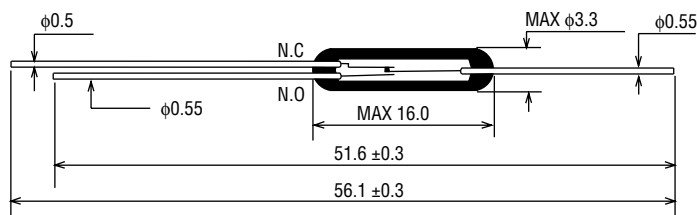

#### APPLICATIONS OF REED SWITCHES

1. Automotive electronic devices
2. Control equipment
3. Communication equipment
4. Measurement equipment
5. Household appliances

**ELECTRICAL CHARACTERISTICS**

Parameter	Symbol	Condition	Rated Value			Unit
			Min.	Typ.	Max.	
Pull-in Value	PI	—	15	—	30	AT
Drop-out Value	DO	—	5	—	—	AT
Contact Resistance	CR	—	—	—	100	mΩ
Breakdown Voltage	—	—	150	—	—	VDC
Insulation Resistance	—	—	10 <sup>9</sup>	—	—	Ω
Electrostatic Capacitance	—	—	—	—	1.5	pF
Contact Rating	—	—	—	—	3	VA
Maximum Switching Voltage	—	—	—	—	30 <sup>DC</sup> <sub>AC</sub>	V
Maximum Switching Current	—	—	—	—	0.2	A
Maximum Carry Current	—	—	—	—	0.5	A

(1) Drop-out vs. Pull-in

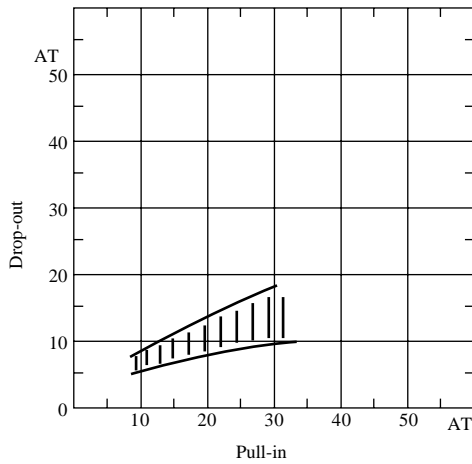

(2) Contact resistance

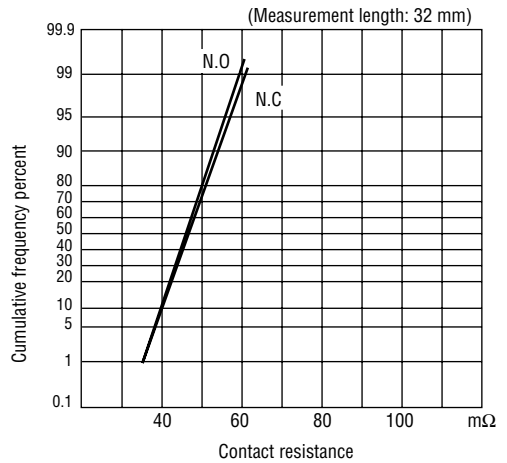

(3) Breakdown voltage

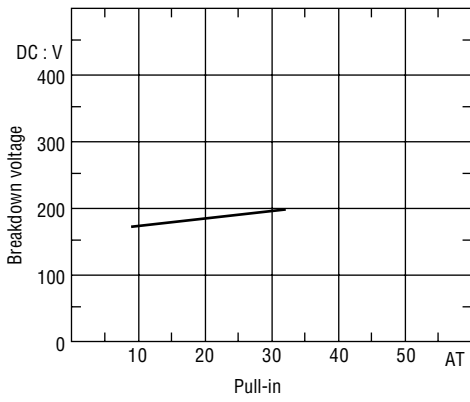

(4) Insulation resistance

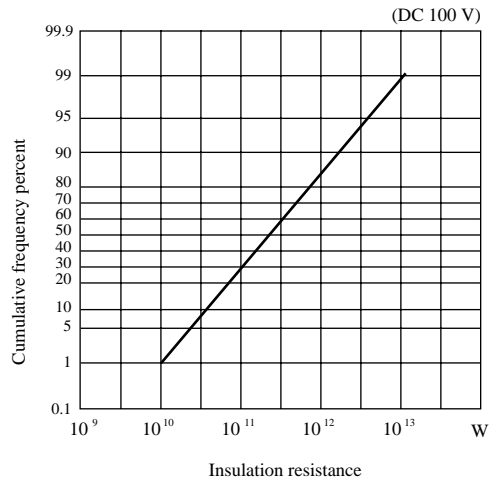

(5) Electrostatic capacitance

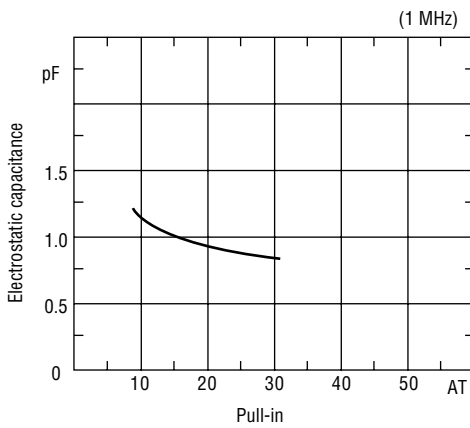

**OPERATING CHARACTERISTICS**

Parameter	Rated Value			Unit
	Min.	Typ.	Max.	
Operate Time	—	—	1.0	ms
Bounce Time	—	—	N.O 1.0	ms
Bounce Time	—	—	N.C 1.5	ms
Release Time	—	—	0.5	ms
Resonant Frequency	2000	6000	10000	Hz
Maximum Operating Frequency	—	—	200	Hz

(1) Operate time

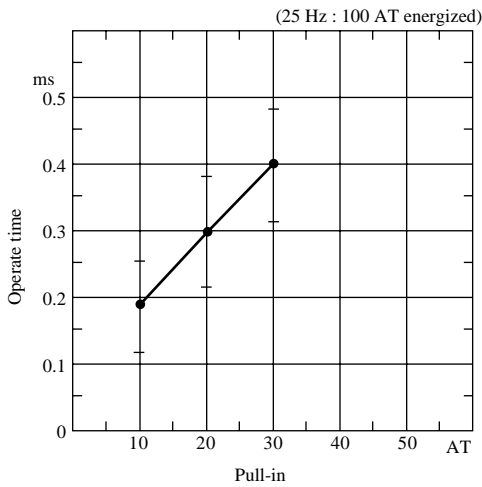

(2) Bounce time

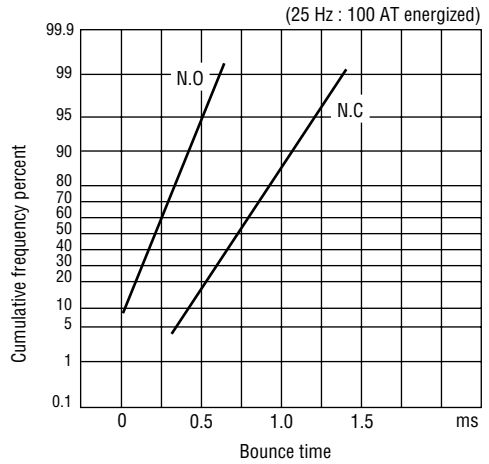

(3) Release time

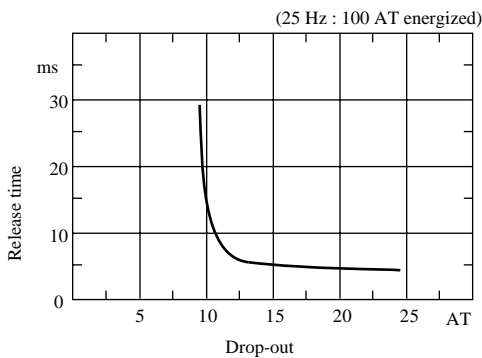

(4) Resonant frequency

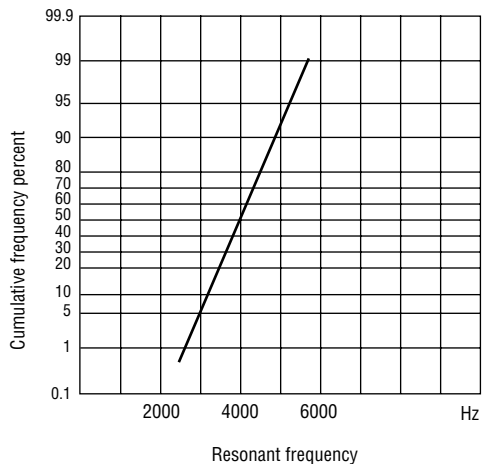

**MECHANICAL CHARACTERISTICS**

(1) Lead tensile test (static load)

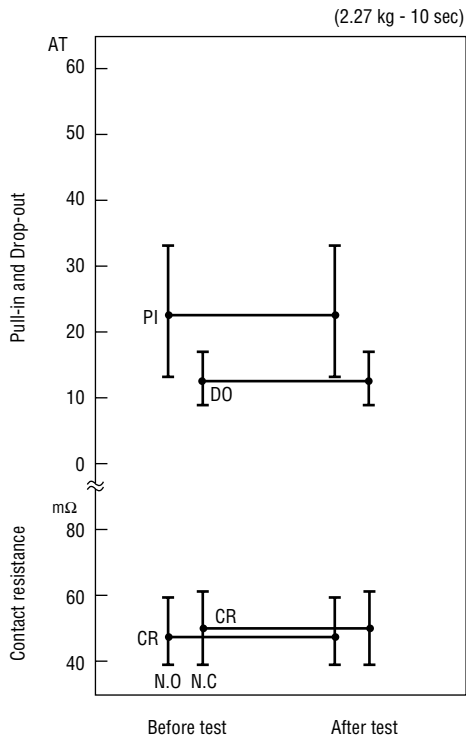

(2) Lead tensile strength

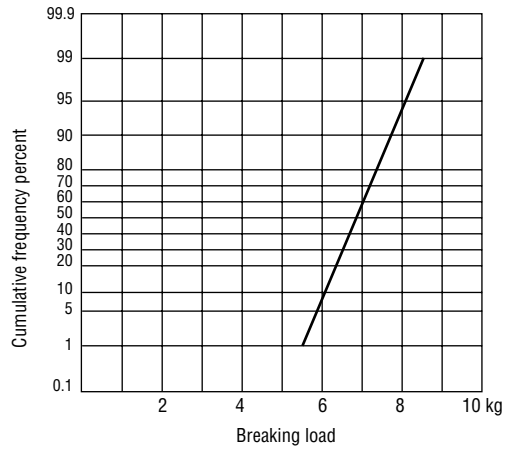

**ENVIRONMENTAL CHARACTERISTICS**

(1) Temperature characteristics

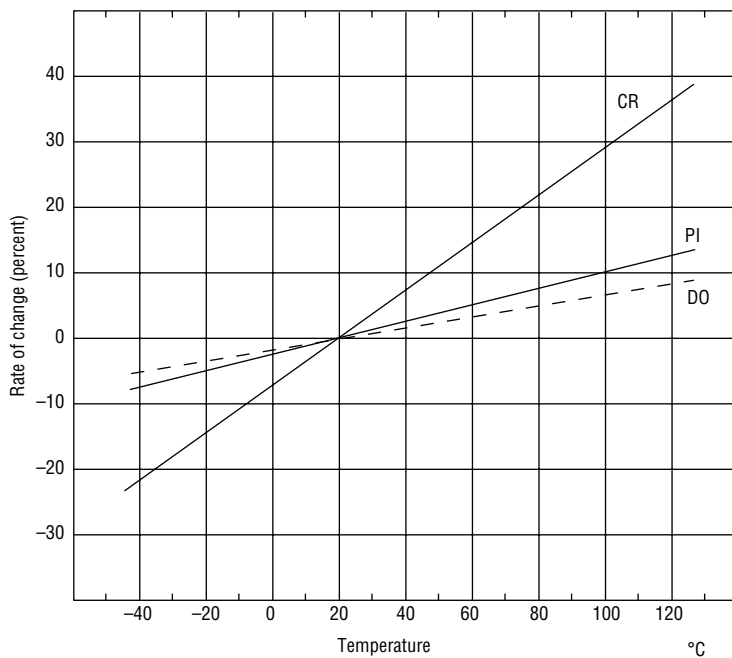

(2) Temperature cycle

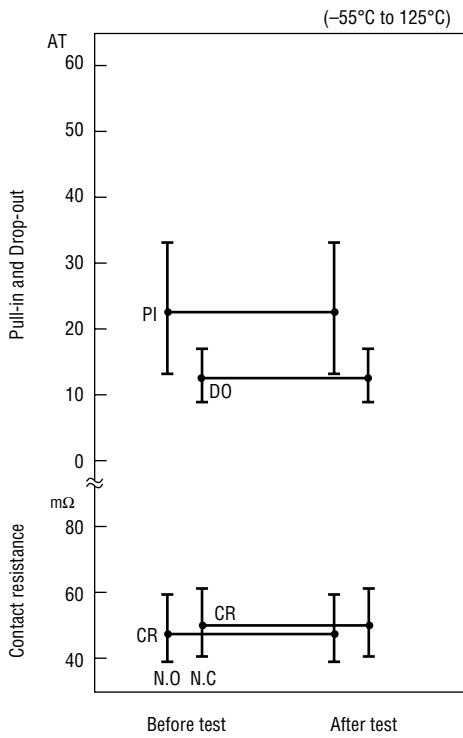

(3) Temperature and humidity cycle

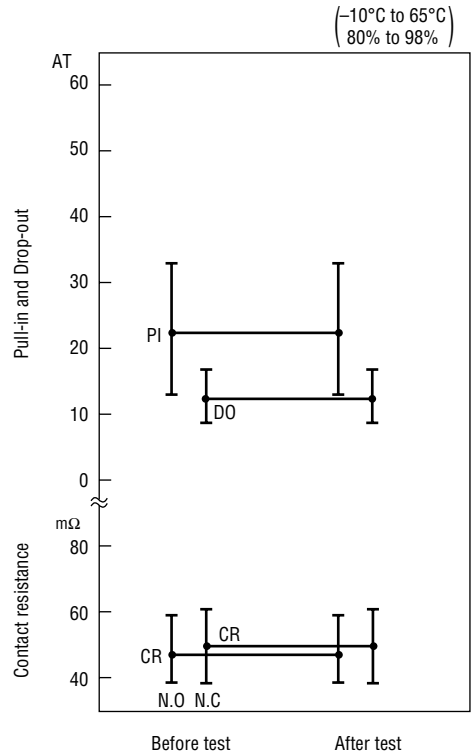

(4) High temperature storage test

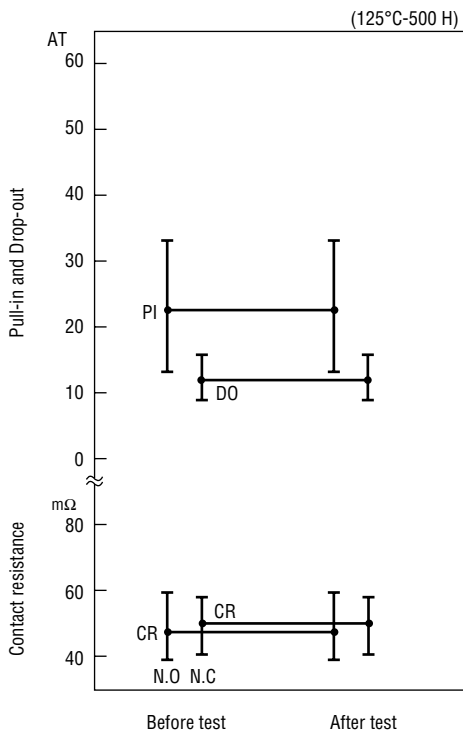

(5) Low temperature storage test

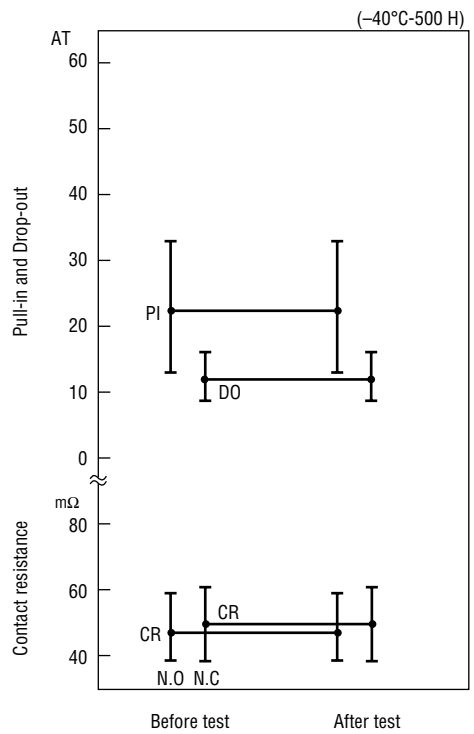

(6) Shock test

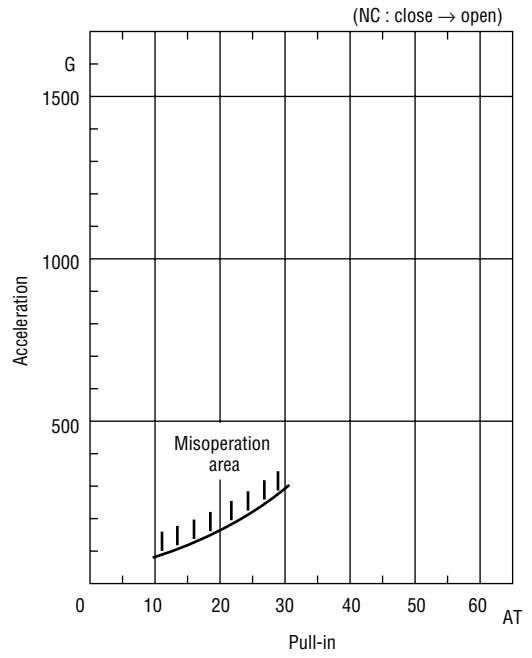
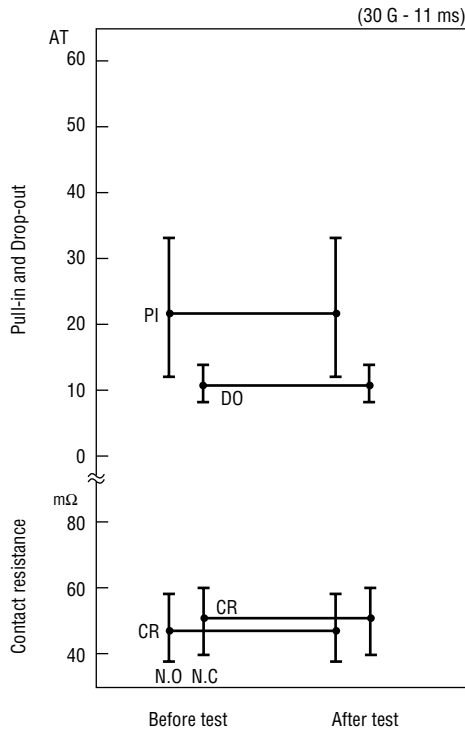

(7) Vibration test

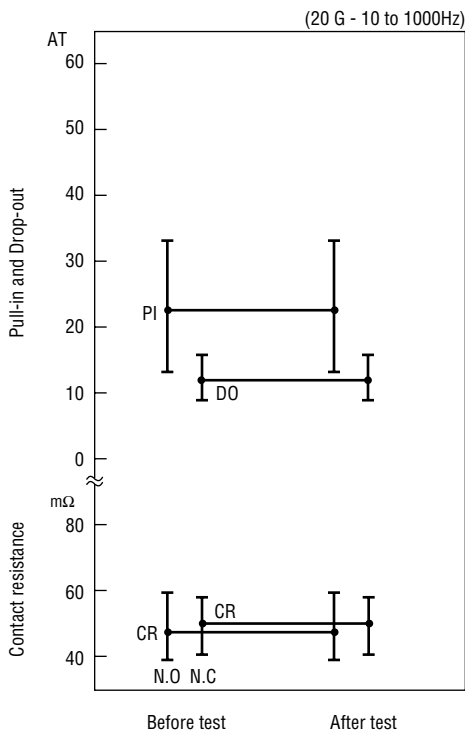



**LIFE EXPECTANCY DATA: ORT233**

Load conditions

Voltage : 5 VDC  
 Current : 100  $\mu$ A, 1 mA, 5 mA  
 Load : Resistive load

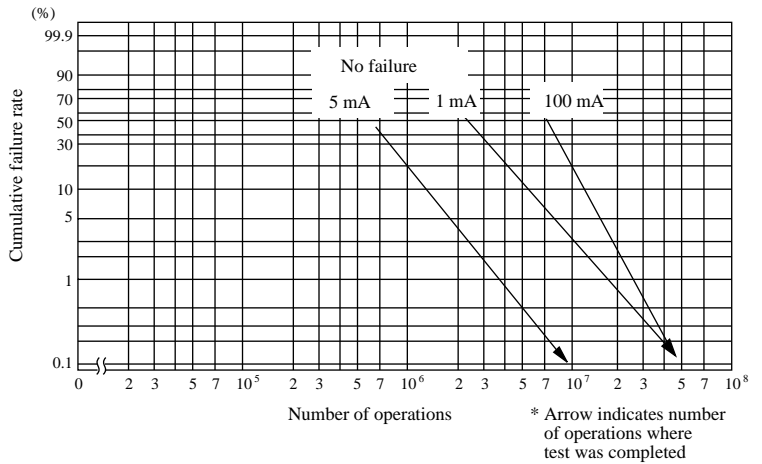

Load conditions

Voltage : 12 VDC  
 Current : 5 mA, 10 mA, 100 mA  
 Load : Resistive load

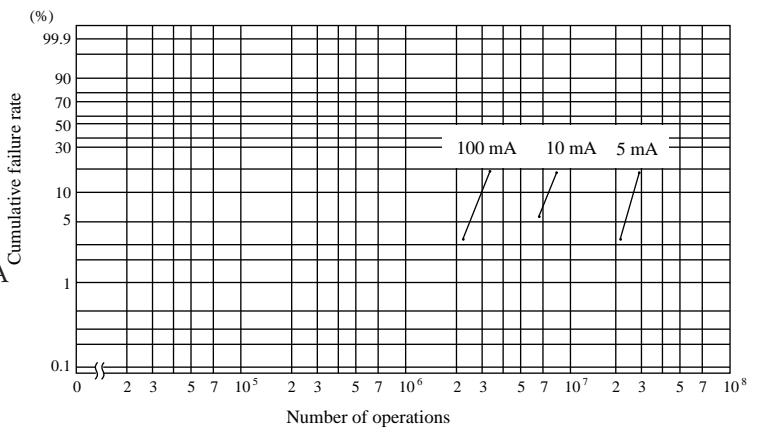

Load conditions

Voltage : 24 VDC  
 Current : 50 mA, 100 mA  
 Load : Resistive load

