



ON Semiconductor®

<http://onsemi.com>

LV52205MU

Bi-CMOS IC

LED Boost Driver with PWM Dimming

Overview

The LV52205MU is a high voltage boost driver for LED drive. LED current is set by the external resistor R1 and LED dimming can be done by changing FB voltage with PWM control.

Features

- Operating Voltage from 2.7V to 5.5V
- PWM dimming for Brightness Control
- Integrated 42V MOSFET
- 600kHz Switching Frequency

Typical Applications

- LED Display Backlight Control

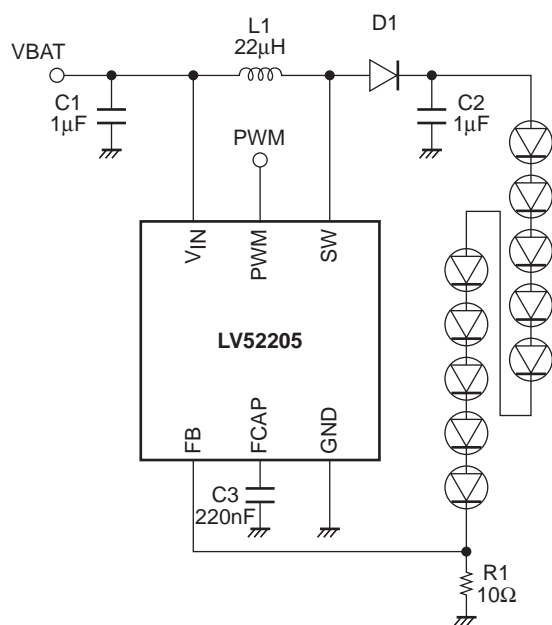

ORDERING INFORMATION

See detailed ordering and shipping information on page 8 of this data sheet.

LV52205MU

Specifications

Absolute Maximum Ratings at $T_a = 25^\circ\text{C}$

Parameter	Symbol	Conditions	Ratings	Unit
Maximum supply voltage	$V_{CC\text{ max}}$	V_{CC}	5.5	V
Maximum pin voltage1	$V1\text{ max}$	SW	42	V
Maximum pin voltage2	$V2\text{ max}$	Other pin	5.5	V
Allowable power dissipation	$Pd\text{ max}$	$T_a = 25^\circ\text{C}^*1$	2.05	W
Operating temperature	T_{opr}		-30 to +85	$^\circ\text{C}$
Storage temperature	T_{stg}		-55 to +125	$^\circ\text{C}$

*1 Mounted on a specified board: 70mm×50mm×1.2mm (4 layer glass epoxy)

Caution 1) Absolute maximum ratings represent the values which cannot be exceeded for any length of time.

Caution 2) Even when the device is used within the range of absolute maximum ratings, as a result of continuous usage under high temperature, high current, high voltage, or drastic temperature change, the reliability of the IC may be degraded. Please contact us for the further details.

Stresses exceeding Maximum Ratings may damage the device. Maximum Ratings are stress ratings only. Functional operation above the Recommended Operating Conditions is not implied. Extended exposure to stresses above the Recommended Operating Conditions may affect device reliability.

Recommendation Operating Condition at $T_a = 25^\circ\text{C}$

Parameter	Symbol	Conditions	Ratings	Unit
Supply voltage range1	$V_{CC\text{ op}}$	V_{CC}	2.7 to 5.5	V
PWM frequency	F_{pwm}		300 to 100k	Hz

Electrical Characteristics Analog block at $T_a = 25^\circ\text{C}$, $V_{CC} = 3.6\text{V}$, unless otherwise specified

Parameter	Symbol	Conditions	Ratings			Unit
			min	typ	max	
Standby current dissipation	I_{CC1}	SHUTDOWN		0	5	μA
DC/DC current dissipation	I_{CC2}	$V_{OUT} = 30\text{V}$, $I_{LED} = 20\text{mA}$			1	mA
FB voltage	V_{fb}	PWM duty 100%	0.19	0.2	0.21	V
FB pin leak current	I_{fb}				1	μA
OVP voltage	V_{ovp}	SW	40	41	42	V
SWOUT ON resistance	R_{on}	$I_L = 100\text{mA}$		700		$\text{m}\Omega$
NMOS switch current limit	I_{LIM}	$V_{fb} = 200\text{mV}$		0.7		A
OSC frequency	F_{osc}			600		kHz
High level input voltage	V_{INH}	PWM	1.5		V_{CC}	V
Low level input voltage	V_{INL}	PWM	0		0.4	V
Under voltage lockout	V_{uvlo}	V_{IN} falling		2.2		V
PWM setup time from shutdown	T_{on}		20			μs
PWM low time to shutdown	T_{off}		8.9			ms

LV52205MU

Block Diagram

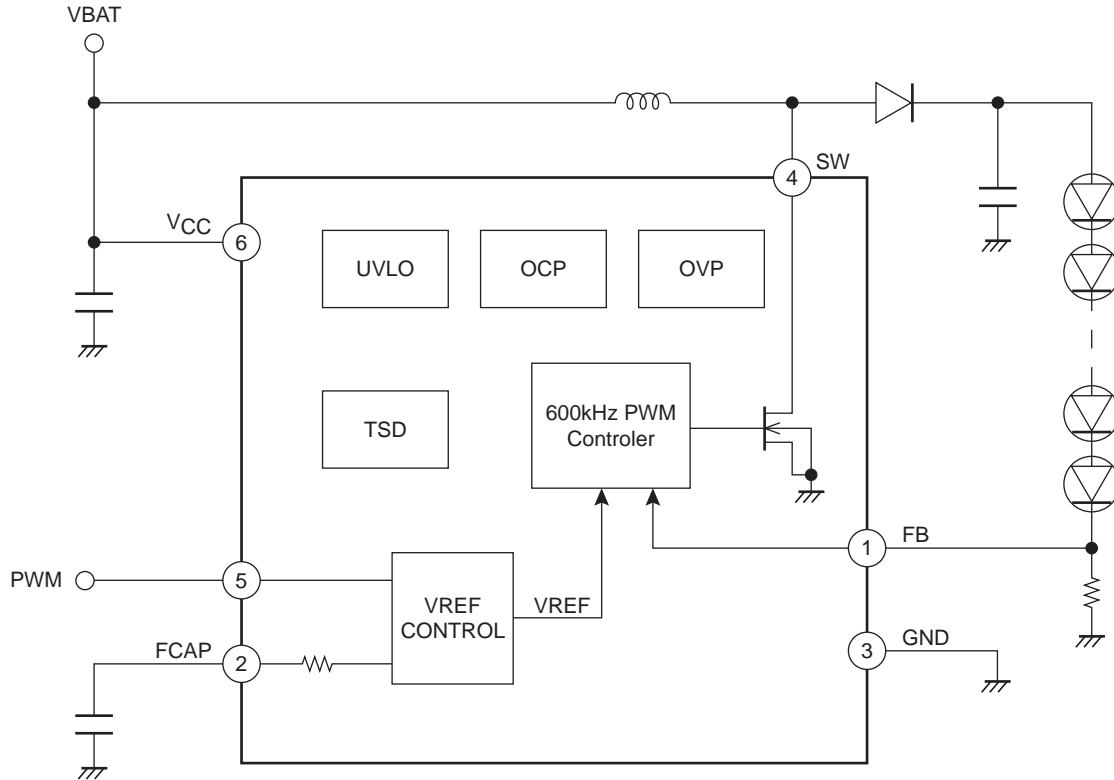

Pin Function

PIN #	Pin Name	Description
1	FB	Feedback pin.
2	FCAP	Filtering capacitor terminal for PWM signal.
3	GND	Ground
4	SW	Switch pin. Drain of the internal power FET.
5	PWM	PWM dimming input (active High).
6	VCC	Supply voltage.
	Expose-pad	Connect to GND on PCB.

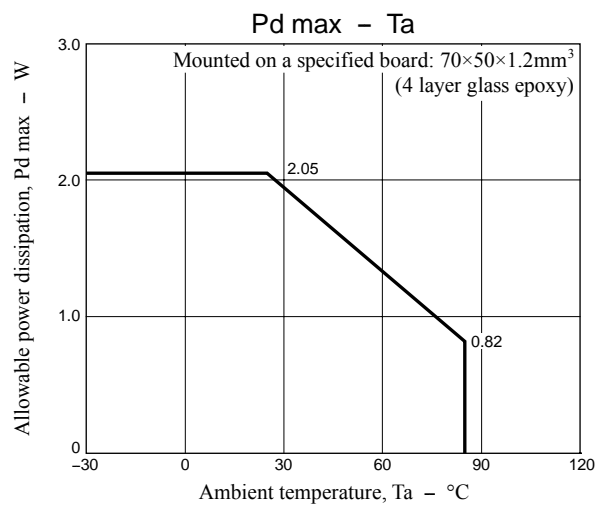

LED Current Setting

LED current is set by an external resistor connected between the FB pin and ground.

$$I_{LED} = V_{FB}/R_{FB}.$$

The V_{FB} can be controlled by PWM signal. PWM input is converted into a near DC current by the internal resistor R that was equivalent to $60k\Omega (\pm 10\%)$ and the external capacitor C_{FCAP} as a low pass filter with a cut-off frequency $f_c = 1/2\pi RC_{FCAP}$. The V_{FB} can be adjusted by altering the duty cycle of the PWM signal (See Fig.1).

$$V_{FB} = 200 \text{ (mV)} \times \text{PWM Duty (\%)}$$

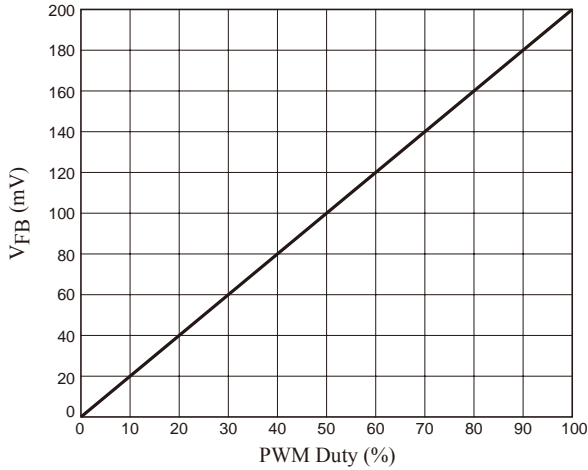

Fig1. V_{FB} vs. PWM Duty

PWM Control

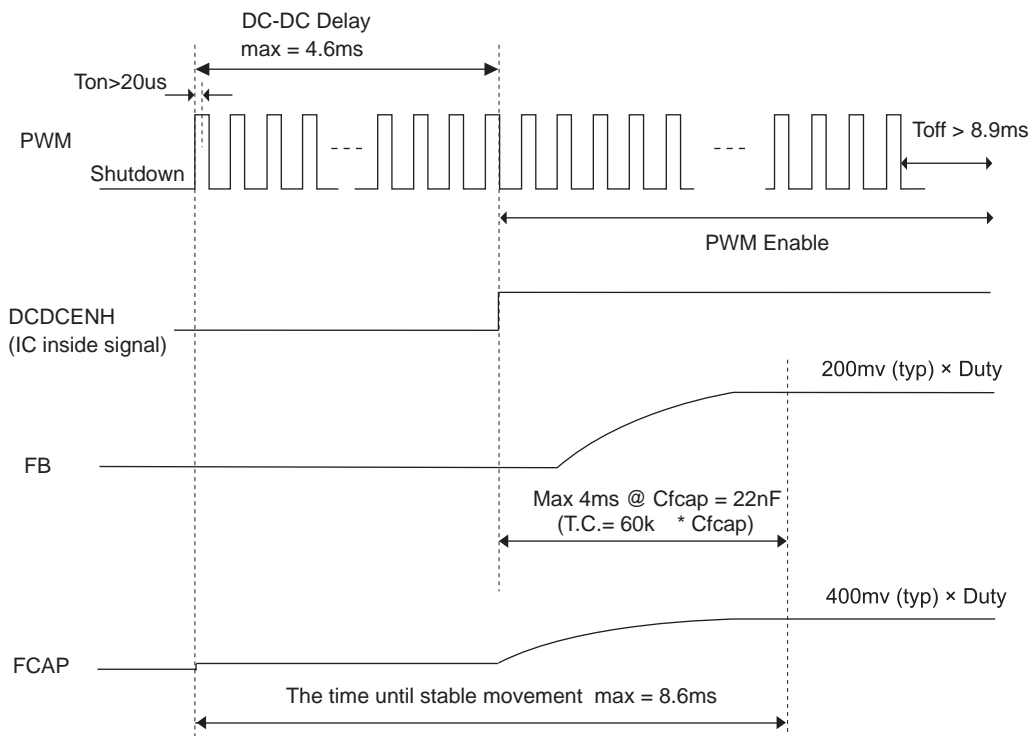

Fig2. Timing Diagram in PWM signal

Open LED Protection

If SW terminal voltage exceeds a threshold V_{ovp} (41V typ) for 8 cycles, boost converter enters shutdown mode. In order to restart the IC, PWM setup signal is required again.

Over Current Protection

Current limit value for built-in power MOS is around 0.7A. The power MOS is turned off for each switching cycle when peak current through it exceeds the limit value.

Under Voltage Lock Out (UVLO)

UVLO operation works when V_{IN} terminal voltage is below 2.2V.

Thermal Shutdown

When chip temperature is too high, boost converter is stopped.

Application Circuit Diagram

10LEDs

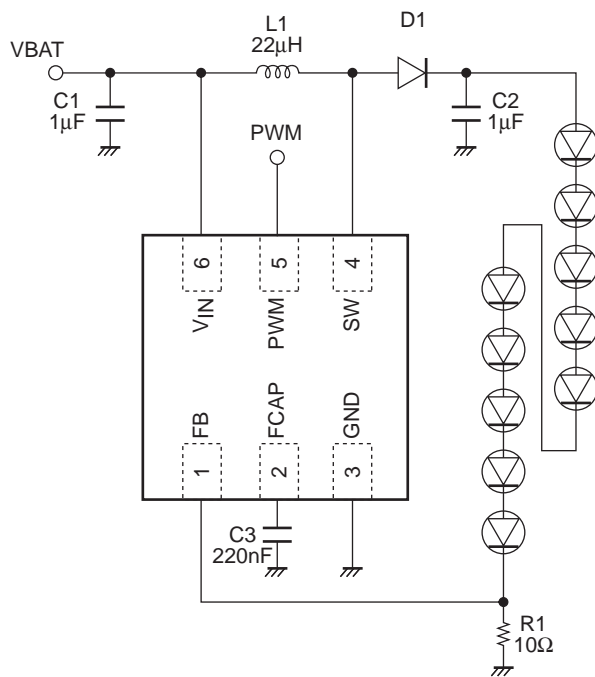

L1: VLS3012T-220M49 (TDK), VLF504015MT-220M (TDK)

D1: MBR0540T1 (ON semi), NSR05F40 (ONsemi)

C2: GRM21BR71H105K (Murata), C1608X5R1H105K (TDK)

LV52205MU

6LEDs

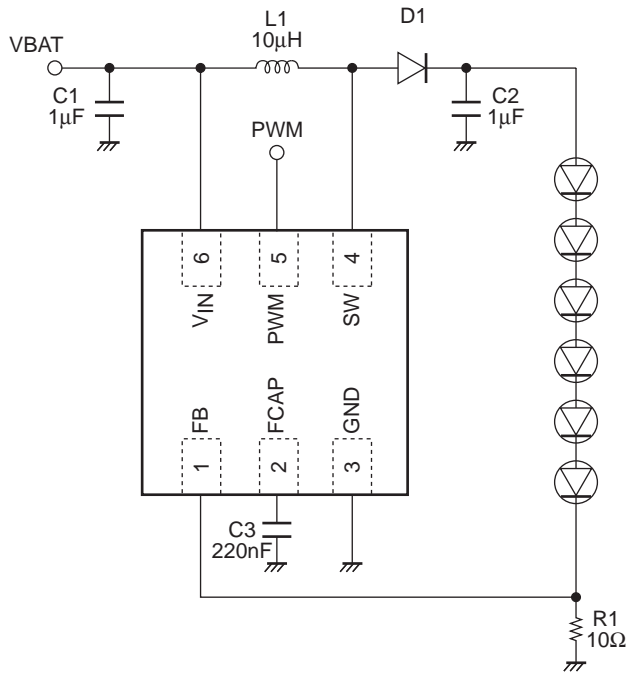

- L1: VLS3012T-100M72 (TDK), VLF302512M-100M (TDK)
D1: MBR0540T1 (ON semi), NSR05F40 (ONsemi)
C2: GRM21BR71H105K (Murata), C1608X5R1H105K (TDK)

LV52205MU

Typical Characteristics ($V_{IN} = 3.6V$, $L = 22\mu H$, $T = 25^\circ C$, unless otherwise specified)

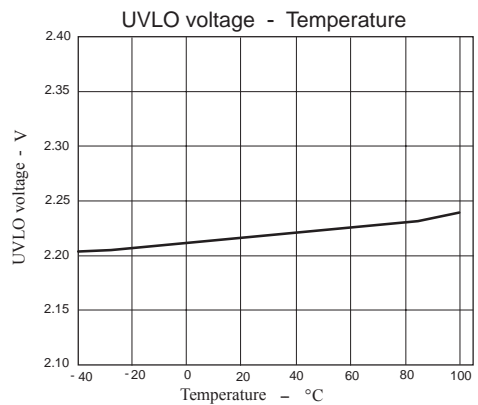
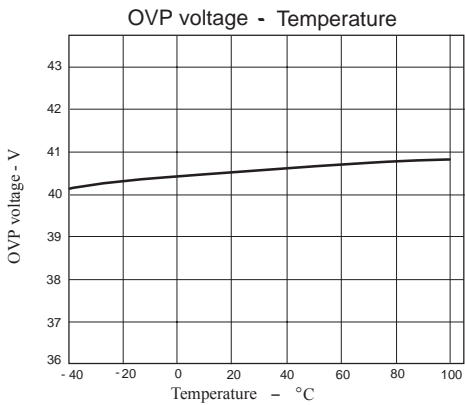
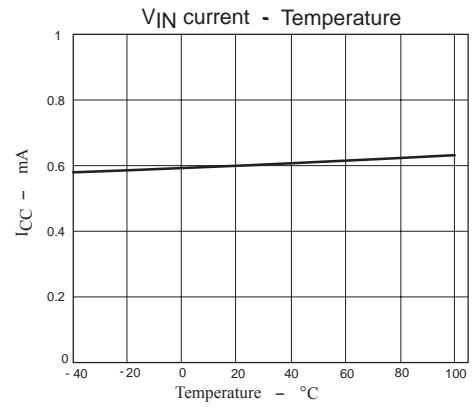
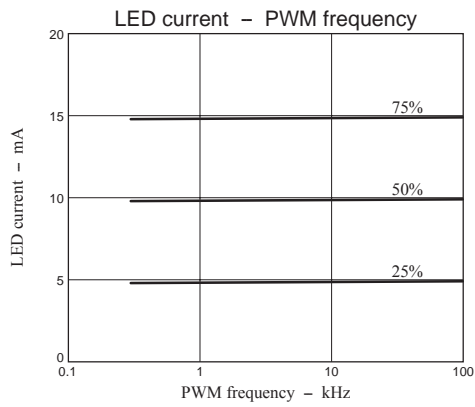
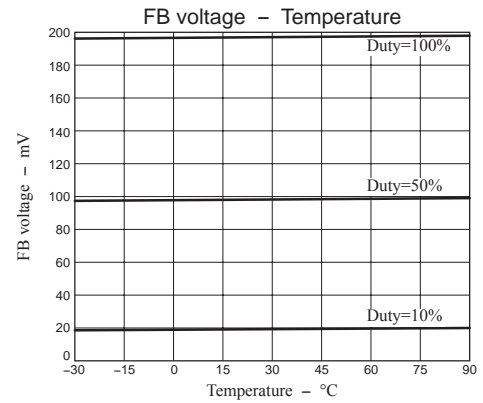
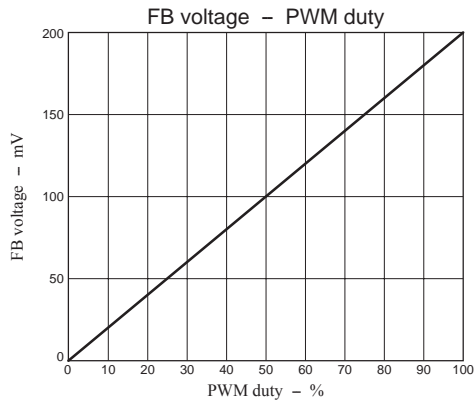
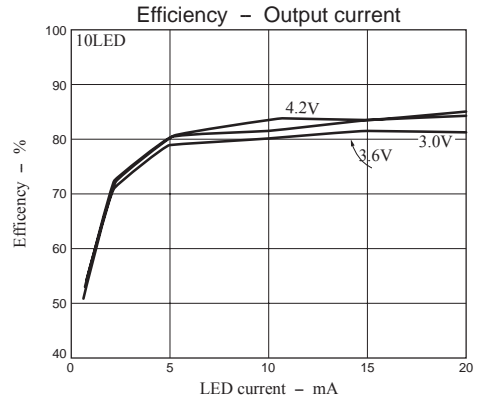
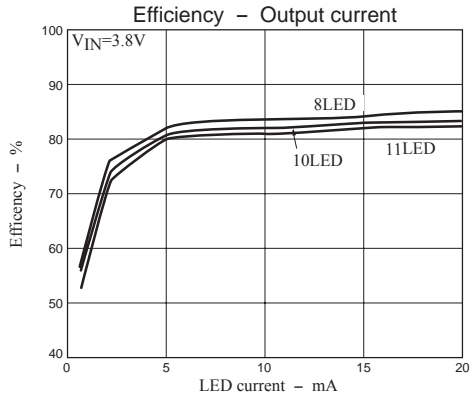

LV52205MU

PACKAGE DIMENSIONS

UDFN6 2x2, 0.65P
CASE 517AB

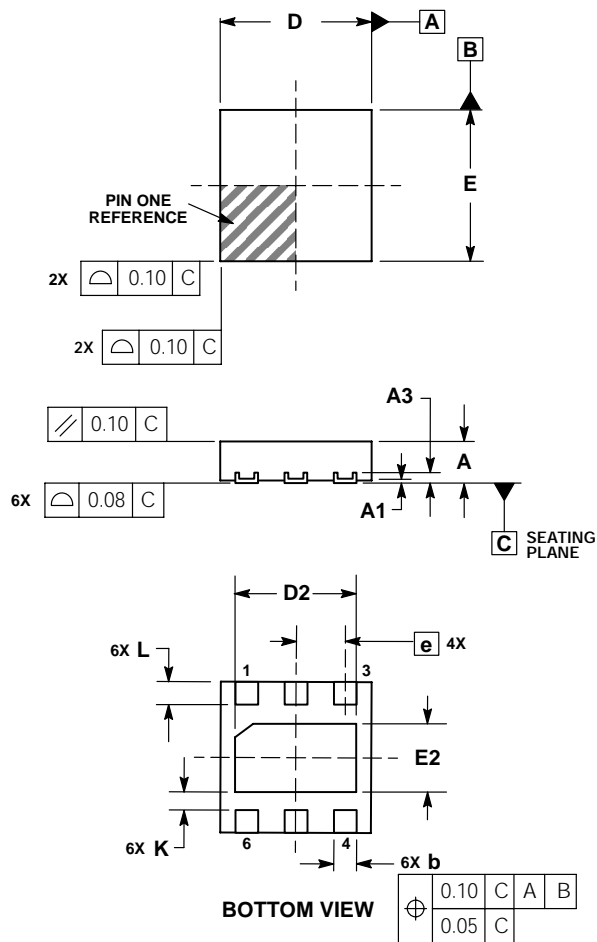

NOTES:

1. DIMENSIONING AND TOLERANCING PER ASME Y14.5M, 1994.
2. CONTROLLING DIMENSION: MILLIMETERS.
3. COPLANARITY APPLIES TO THE EXPOSED PAD AS WELL AS THE TERMINALS.

DIM	MILLIMETERS	
	MIN	MAX
A	0.45	0.55
A1	0.00	0.05
A3	0.127 REF	
b	0.25	0.35
D	2.00 BSC	
D2	1.50	1.70
E	2.00 BSC	
E2	0.80	1.00
e	0.65 BSC	
K	0.20	---
L	0.25	0.35

SOLDERING FOOTPRINT*

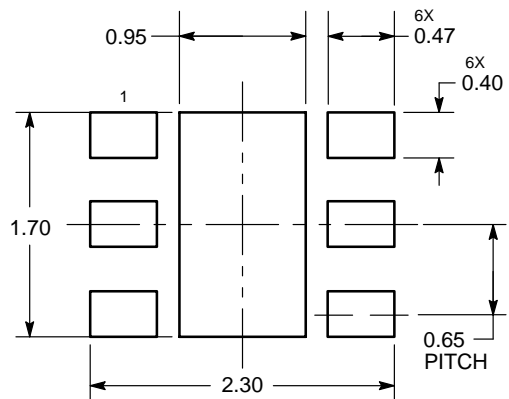

DIMENSIONS: MILLIMETERS

*For additional information on our Pb-Free strategy and soldering details, please download the ON Semiconductor Soldering and Mounting Techniques Reference Manual, SOLDERRM/D.

ORDERING INFORMATION

Device	Package	Shipping (Qty / Packing)
LV52205MUTBG	UDFN6 (2x2) (Pb-Free)	3000 / Tape & Reel

ON Semiconductor and the ON logo are registered trademarks of Semiconductor Components Industries, LLC (SCILLC). SCILLC owns the rights to a number of patents, trademarks, copyrights, trade secrets, and other intellectual property. A listing of SCILLC's product/patent coverage may be accessed at www.onsemi.com/site/pdf/Patent-Marking.pdf. SCILLC reserves the right to make changes without further notice to any products herein. SCILLC makes no warranty, representation or guarantee regarding the suitability of its products for any particular purpose, nor does SCILLC assume any liability arising out of the application or use of any product or circuit, and specifically disclaims any and all liability, including without limitation special, consequential or incidental damages. "Typical" parameters which may be provided in SCILLC data sheets and/or specifications can and do vary in different applications and actual performance may vary over time. All operating parameters, including "Typicals" must be validated for each customer application by customer's technical experts. SCILLC does not convey any license under its patent rights nor the rights of others. SCILLC products are not designed, intended, or authorized for use as components in systems intended for surgical implant into the body, or other applications intended to support or sustain life, or for any other application in which the failure of the SCILLC product could create a situation where personal injury or death may occur. Should Buyer purchase or use SCILLC products for any such unintended or unauthorized application, Buyer shall indemnify and hold SCILLC and its officers, employees, subsidiaries, affiliates, and distributors harmless against all claims, costs, damages, and expenses, and reasonable attorney fees arising out of, directly or indirectly, any claim of personal injury or death associated with such unintended or unauthorized use, even if such claim alleges that SCILLC was negligent regarding the design or manufacture of the part. SCILLC is an Equal Opportunity/Affirmative Action Employer. This literature is subject to all applicable copyright laws and is not for resale in any manner.