



SGM9116

Triple, 35MHz, 6th Order HDTV Video Filter Driver

PRODUCT DESCRIPTION

The SGM9116 is a video buffer which integrates triple 6dB Gain rail-to-rail output driver and triple 6th output reconstruction filter, it has 35MHz -3dB bandwidth and 159V/ μ s slew rate. SGM9116 provides improved image quality compared with passive LC filters and discrete drivers solution. Operating from single supplies ranging from +3.3V to +5.5V and sinking an ultra-low 39.4mA quiescent current, the SGM9116 is ideally suited for battery powered applications.

SGM9116 can be DC-coupled or AC-coupled with input video signal, such as the output of DAC. Internal diode clamps and bias circuitry may be used if AC-coupled inputs are required. SGM9116 also integrates an internal level shift circuit which avoids sync-pulse being clipped and allows DC-coupled output. The driver in SGM9116 can drive DC or AC-coupled single (150 Ω) or dual (75 Ω) loads.

The SGM9116 has Green SO-8 package.

BLOCK DIAGRAM

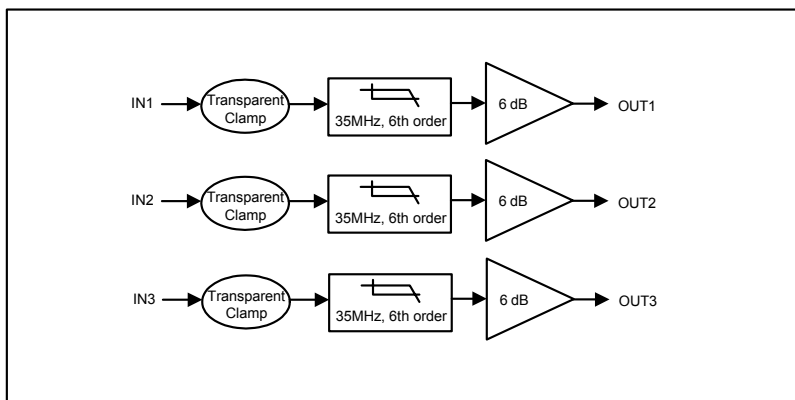

FEATURES

- Triple 6th Order 35MHz (HD) Filters
- Transparent Input Clamping
- 6dB Output Driver Gain and Drive Dual Video Load
- Rail-to-Rail Output
- Input Voltage Range Includes Ground
- AC or DC Coupled Inputs
- AC or DC Coupled Outputs
- Operates from 3.3V to 5.5V Single Power Supply
- Low Power
 - 39.4mA Total Supply Current
- Green SO-8 Package

APPLICATIONS

- Video Amplifier
- Cable and Satellite Set- Top Box
- Communications Device
- Video on Demand
- Portable and Handheld Product
- Personal Video Recorder
- DVD Players
- HDTV
- Projector

PACKAGE/ORDERING INFORMATION

ORDER NUMBER	PACKAGE DESCRIPTION	TEMPERATURE RANGE	PACKAGE OPTION	MARKING INFORMATION
SGM9116XS/TR	SO-8	-40°C to +125°C	Tape and Reel, 2500	SGM9116XS

PIN CONFIGURATION (Top View)

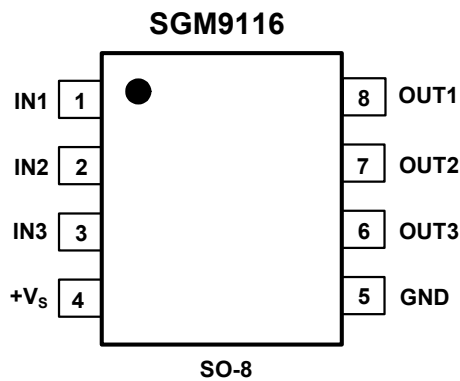

PIN DESCRIPTION

PIN	NAME	FUNCTION
1	IN1	Video input, channel 1
2	IN2	Video input, channel 2
3	IN3	Video input, channel 3
4	+Vs	Power supply
5	GND	Ground
6	OUT3	Filtered output, channel 3
7	OUT2	Filtered output, channel 2
8	OUT1	Filtered output, channel 1

ABSOLUTE MAXIMUM RATINGS

Supply Voltage, V+ to V- 6V
 Input Voltage..... GND - 0.3 V to (+Vs) +0.3V
 Storage Temperature Range-65°C to +150°C
 Junction Temperature150°C
 Operating Temperature Range-40°C to +125°C
 Power Dissipation, P_D @ T_A = 25°C
 SO-80.8W
 Package Thermal Resistance
 SO-8, θ_{JA}..... 128°C/W
 Lead Temperature Range (Soldering 10 sec)
 260°C
 ESD Susceptibility
 HBM.....8000V
 MM.....400V

NOTE

Stresses above those listed under Absolute Maximum Ratings may cause permanent damage to the device. This is a stress rating only; functional operation of the device at these or any other conditions above those indicated in the operational section of this specification is not implied. Exposure to absolute maximum rating conditions for extended periods may affect device reliability.

CAUTION

This integrated circuit can be damaged by ESD if you don't pay attention to ESD protection. SGMICRO recommends that all integrated circuits be handled with appropriate precautions. Failure to observe proper handling and installation procedures can cause damage. ESD damage can range from subtle performance degradation to complete device failure. Precision integrated circuits may be more susceptible to damage because very small parametric changes could cause the device not to meet its published specifications.

ELECTRICAL CHARACTERISTICS: $V_S = +5.0V$ (At $R_L = 150\Omega$ connected to GND, $V_{IN} = 1V_{pp}$, and $C_{IN} = 0.1\mu F$, all outputs AC coupled with $220\mu F$, unless otherwise noted)

PARAMETER	CONDITIONS	SGM9116					
		TYP	MIN/MAX OVER TEMPERATURE			UNITS	MIN/ MAX
		+25°C	+25°C	-40°C to 125°C			
INPUT CHARACTERISTICS							
Output Level Shift Voltage (V_{OLS})	$V_{IN} = 0V$, no load	494	638	785	mV	MAX	
Clamp Charge Current	$V_{IN} = V_{CLAMP} - 100mV$	-4.2	-5.4	-5.6	mA	MIN	
Voltage Gain (A_V)	$R_L = 150\Omega$	6	5.89	5.60	dB	MIN	
			6.36	6.52	dB	MAX	
OUTPUT CHARACTERISTICS							
Output Voltage High Swing	$V_{IN} = 3V$, $R_L = 150\Omega$ to GND	4.79	4.73	4.71	V	MIN	
POWER SUPPLY							
Operating Voltage Range			3.3		V	MIN	
			5.5		V	MAX	
Power Supply Rejection Ratio (PSRR)	$V_S = +3.5V$ to $+5.0V$	60	48	43	dB	MIN	
Quiescent Current (I_Q)	$V_{IN} = 0V$	39.4	48	62	mA	MAX	
DYNAMIC PERFORMANCE							
-0.1dB Bandwidth	$R_L = 150\Omega$	29.4			MHz	TYP	
-3dB Bandwidth	$R_L = 150\Omega$	35			MHz	TYP	
Filter Response (Normalized Gain)	$f_{IN} = 74.25MHz$	-34.6			dB	TYP	
Slew Rate	2V Output Step, 80% to 20%	159			V/ μs	TYP	
Differential Gain (DG)	PAL DC coupled	0.04			%	TYP	
	PAL AC coupled	0.32			%	TYP	
Differential Phase (DP)	PAL DC coupled	0.47			°	TYP	
	PAL AC coupled	0.57			°	TYP	
Group Delay Variation (D/DT)	$f = 400KHz$, 20MHz	4			ns	TYP	
Crosstalk (channel - to - channel)	at 1MHz	-70			dB	TYP	
Fall Time	$2.0V_{STEP}$, 80% to 20%	7.62			ns	TYP	
Rise Time	$2.0V_{STEP}$, 80% to 20%	7.6			ns	TYP	

Specifications subject to change without notice.

TYPICAL PERFORMANCE CHARACTERISTICS

At $V_S = +5.0V$, $T_A = +25^\circ C$, $R_L = 150\Omega$, all outputs AC coupled with $220\mu F$, unless otherwise noted.

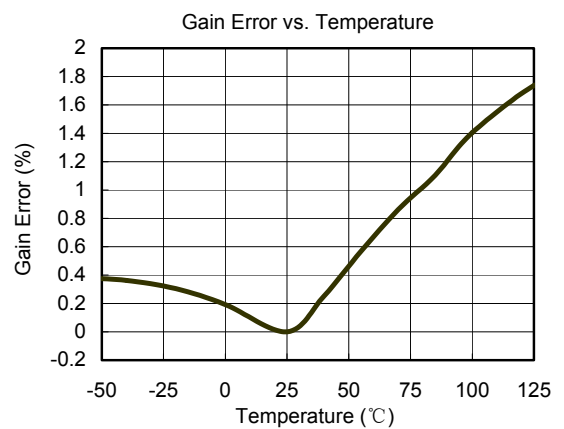
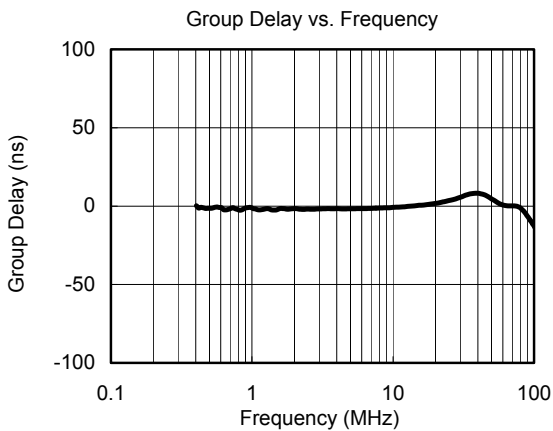
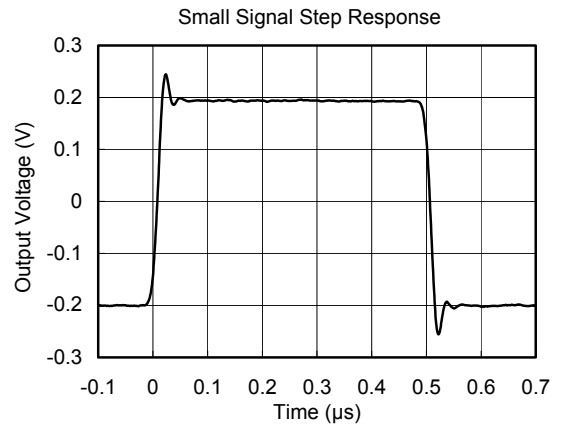
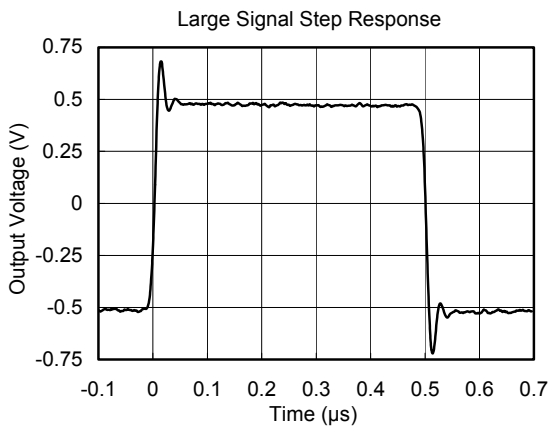
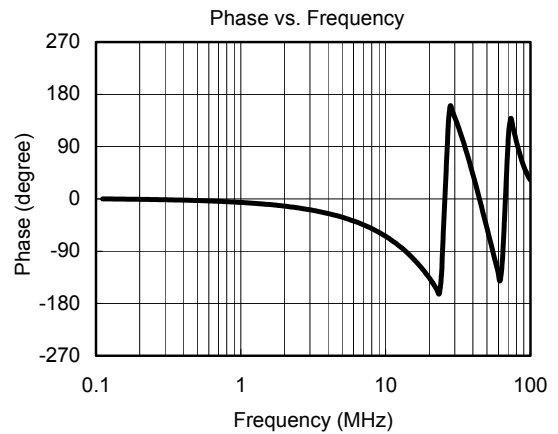
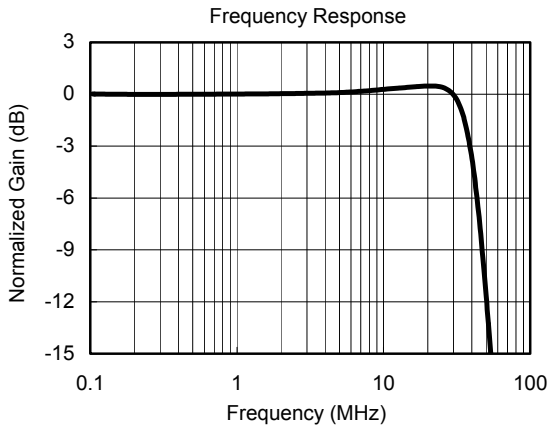

TYPICAL PERFORMANCE CHARACTERISTICS

At $V_S = +5.0V$, $T_A = +25^\circ C$, $R_L = 150\Omega$, all outputs AC coupled with $220\mu F$, unless otherwise noted.

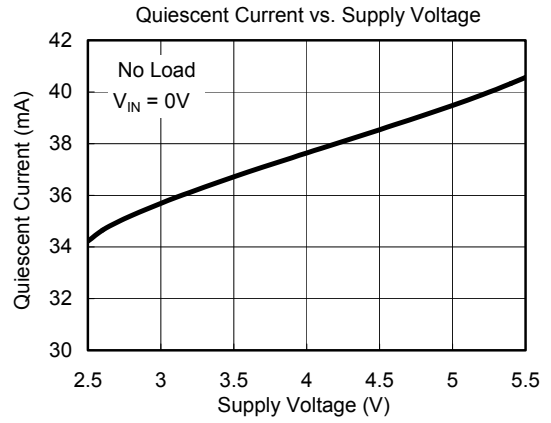
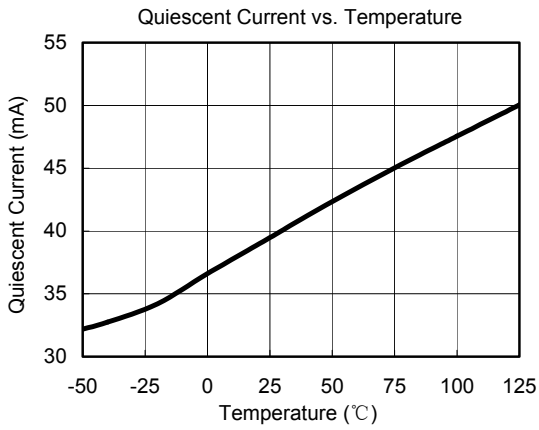

APPLICATIONS INFORMATION

Functional Description

SGM9116 operates from a single +3.3V to +5.5V supply. In application, SGM9116 is a fully integrated solution for filtering and buffering HDTV signals in front of video decoder or behind video encoder. For example, SGM9116 can replace three passive LC filters and three amplifier drivers at R\G\B and Y\Pb\Pr output side in set-top box and DVD player, this solution can help you save PCB size and production cost, it also improves video signal performance comparing with traditional design using discrete components. SGM9116 features a DC-coupled input buffer, 6-pole low-pass filter to eliminate out-of-band noise of video encoder, and a gain of +6dB in the output amplifier to drive 75Ω load. The AC or DC-coupled input buffer eliminates sync crush, droop, and field tilt. The output of SGM9116 also can be DC-coupled or AC-coupled.

Input Considerations

Besides AC coupling, the SGM9116 inputs also can be DC-coupled. In DC coupling application, No input coupling capacitors are needed because the amplitude of input video signal from DAC includes ground and extends up to 1.4V, then SGM9116 can be directly connected to the output of a single-supply, current-output DAC without any external bias network. Some time, if DAC's output level exceeds the range of 0V to 1.4V, or SGM9116 is driven by an unknown external source or a SCART switch which has its own clamping circuit, AC coupling is needed in such application.

Output Considerations

The SGM9116 outputs can be DC-coupled or AC-coupled. While 0V is input, the SGM9116 output voltage is 494mV typically. In DC coupling design, one 75Ω resistor is used to connect SGM9116's output pin with external load directly, this serial back-termination resistor is used to match the impedance of the transmission line between SGM9116 and external load to cancel the signal reflection. The SGM9116 outputs can sink and source current allowing the device to be AC-coupled with external load, in AC coupling, 220μF at least capacitor will be used in order to cancel field tilt.

Power-Supply Bypassing and Layout

Correct power supply bypassing is very important for optimizing video performance in design. One 0.1μF and one 10μF capacitors are always used to Bypass V_{CC} pin of SGM9116, please place these two capacitors as close to the SGM9116

output pin as possible, a large ground plane is also needed to ensure optimum performance. The input and output termination resistors should be placed as close to the related pin of SGM9116 as possible to avoid performance degradation. The PCB traces at the output side should have 75Ω characteristic impedance in order to match the 75Ω characteristic impedance cable connecting external load. In design, please keep the board trace at the inputs and outputs of the SGM9116 as short as possible to minimize the parasitic stray capacitance and noise pickup.

Typical Application Diagram

The following schematic in Figure 1 is normally used for AC coupled output and DC-coupled input with DAC which has an output voltage range of 0V to 1.4V. AC coupled output offer slightly lower power dissipation and high ESD protection ability. Figure 2 is a kind of special application in STB.

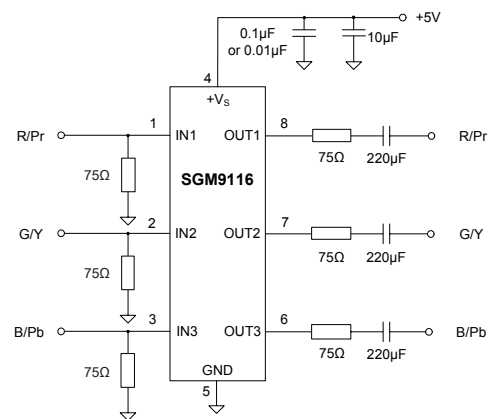

Figure 1. Input DC Coupling and Output AC Coupling Application Schematic

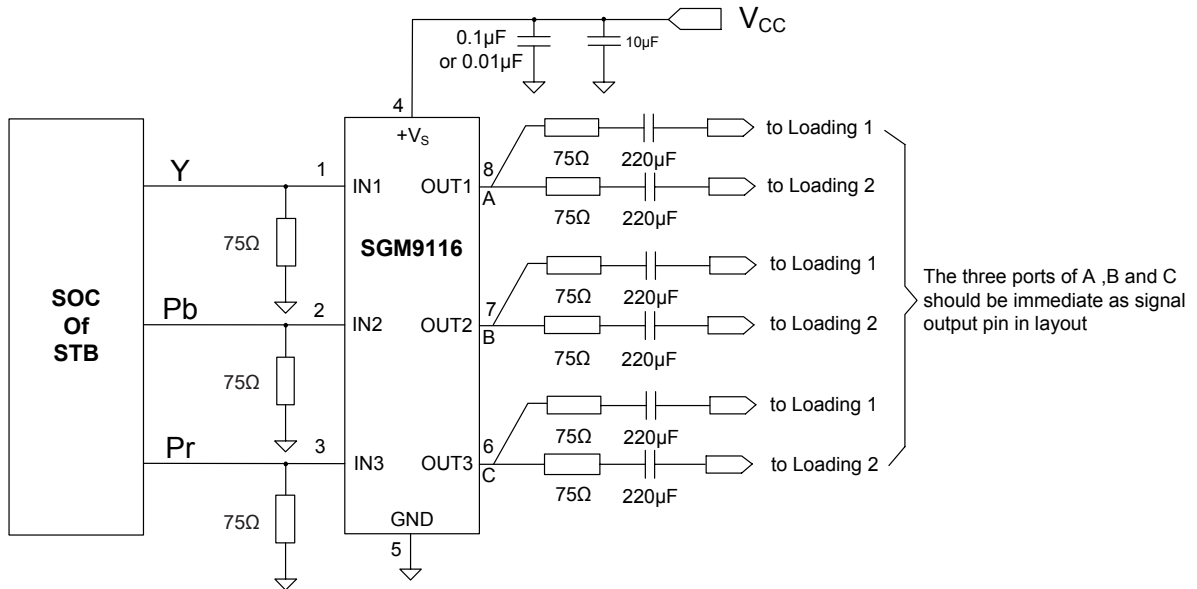
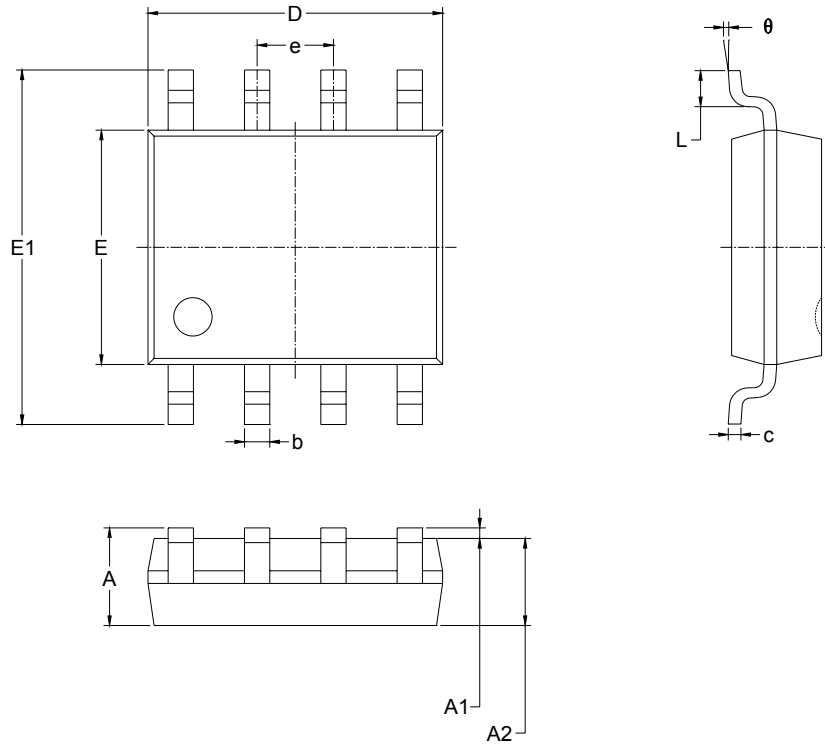

Figure 2. The DC Coupling Circuit Schematic is recommended in applications of STB

PACKAGE OUTLINE DIMENSIONS

SO-8



Symbol	Dimensions In Millimeters		Dimensions In Inches	
	Min	Max	Min	Max
A	1.350	1.750	0.053	0.069
A1	0.100	0.250	0.004	0.010
A2	1.350	1.550	0.053	0.061
b	0.330	0.510	0.013	0.020
c	0.170	0.250	0.006	0.010
D	4.700	5.100	0.185	0.200
E	3.800	4.000	0.150	0.157
E1	5.800	6.200	0.228	0.244
e	1.27 BSC		0.050 BSC	
L	0.400	1.270	0.016	0.050
θ	0°	8°	0°	8°

05/2010 REV. C

SGMICRO is dedicated to provide high quality and high performance analog IC products to customers. All SGMICRO products meet the highest industry standards with strict and comprehensive test and quality control systems to achieve world-class consistency and reliability.

For more information regarding SGMICRO Corporation and its products, please visit www.sg-micro.com