



SGM3127

White LED Driver with Low Dropout Current Source

GENERAL DESCRIPTION

The SGM3127 low-dropout bias supply for white LEDs is a high-performance alternative to the simple ballast resistors used in conventional white LED designs. It is optimized for low power keypad and portable backlighting applications.

The SGM3127 uses an internal resistor to set the bias current for four LEDs, which are matched to $\pm 5\%$. The SGM3127's advantages over ballast resistors include much lower bias variation with supply voltage variation, significantly lower dropout voltage, and in some applications, significantly improved efficiency.

The SGM3127 requires only a 50mV dropout voltage at a 30mA load on each output to match the LED brightness.

The SGM3127 is available in Green SOT-23-6L package. It operates over an ambient temperature range of -40°C to $+85^{\circ}\text{C}$.

FEATURES

- Support up to 4 LEDs
- Low 50mV Dropout at 30mA
- Less than $\pm 5\%$ LED Current Matching
- Simple LED Brightness Control
- Low Shutdown Current
- 2.5V to 5.5V Supply Voltage Range
- Thermal Shutdown Protection
- Operating Temperature Range: -40°C to $+85^{\circ}\text{C}$
- Available in Green SOT-23-6L Package

APPLICATIONS

Wireless Handsets
MP3, MP4, and PMP
Cellular Phones
Portable Communication Devices
Digital Cameras, Camcorders
PDAs, Palmtops, and Handy Terminals
LED/Display Back Light Driver
LEDs for Camera Flash
Battery-Powered Equipment



PACKAGE/ORDERING INFORMATION

MODEL	ORDER NUMBER	PACKAGE DESCRIPTION	SPECIFIED TEMPERATURE RANGE	PACKAGE OPTION	MARKING INFORMATION
SGM3127	SGM3127YN6G/TR	SOT-23-6L	-40°C to +85°C	Tape and Reel, 3000	S01XX

NOTE: Order number and package marking are defined as the follow:

ORDER NUMBER

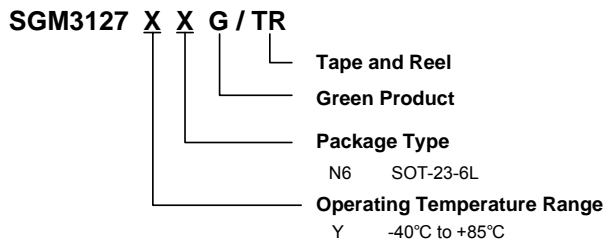

MARKING INFORMATION

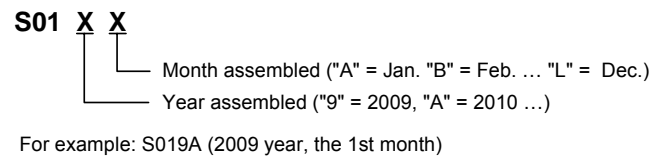

PIN CONFIGURATION (TOP VIEW)

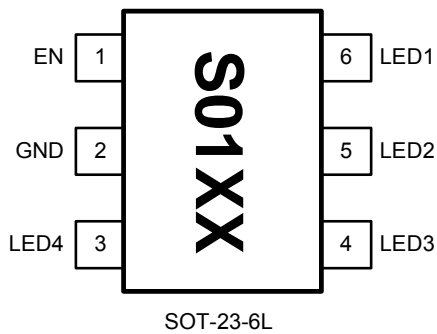

NOTE: The location of pin 1 on the S01XX is determined by orienting the package marking as shown.

CAUTION

This integrated circuit can be damaged by ESD if you don't pay attention to ESD protection. SGMICRO recommends that all integrated circuits be handled with appropriate precautions. Failure to observe proper handling and installation procedures can cause damage. ESD damage can range from subtle performance degradation to complete device failure. Precision integrated circuits may be more susceptible to damage because very small parametric changes could cause the device not to meet its published specifications.

ABSOLUTE MAXIMUM RATINGS

V_{IN} to GND.....	-0.3V to 6V
The Other Pins to GND.....	-0.3V to 6V
Storage Temperature Range.....	-65°C to +150°C
Junction Temperature.....	150°C
Operating Temperature Range.....	-40°C to +85°C
Power Dissipation, P_D @ $T_A = 25^\circ\text{C}$	
SOT-23-6L.....	0.5W
Package Thermal Resistance	
SOT-23-6L, θ_{JA}	250°C/W
Lead Temperature Range (Soldering 10 sec)	
.....	260°C
ESD Susceptibility	
HBM.....	4000V
MM.....	400V

NOTE:

Stresses above those listed under Absolute Maximum Ratings may cause permanent damage to the device. This is a stress rating only; functional operation of the device at these or any other conditions above those indicated in the operational section of this specification is not implied. Exposure to absolute maximum rating conditions for extended periods may affect device reliability.

PIN DESCRIPTION

PIN	NAME	FUNCTION
1	EN	Enable Input/Power Input. (Active High). When disabled, LED1, LED2, LED3 and LED4 are high impedance. When enabled, EN is the power input for the SGM3127.
2	GND	Ground.
3	LED4	LED4 Output Pin. Connect to LED4's Cathode. 30mA Constant Current Output. LED4 is High Impedance when EN is Low.
4	LED3	LED3 Output Pin. Connect to LED3's Cathode. 30mA Constant Current Output. LED3 is High Impedance when EN is Low.
5	LED2	LED2 Output Pin. Connect to LED2's Cathode. 30mA Constant Current Output. LED2 is High Impedance when EN is Low.
6	LED1	LED1 Output Pin. Connect to LED1's Cathode. 30mA Constant Current Output. LED1 is High Impedance when EN is Low.

ELECTRICAL CHARACTERISTICS

(V_{IN} = 3.7V, T_A = +25°C, unless otherwise noted.)

PARAMETER	SYMBOL	CONDITIONS	MIN	TYP	MAX	UNITS
Operation Voltage Range	V _{EN}		2.5		5.5	V
Under Voltage Lock Out	V _{UVLO}	Falling		2.1		V
UVLO Hysteresis				110		mV
LED Sink Current	I _{LED}		27	30	33	mA
Quiescent Power Supply Current	I _{EN}	I _{LED} = 0		240		μA
LED Dropout Voltage		I _{LED} = 30mA, V _{LED} @ I _{LEDn} = 90% × I _{LED}		50		mV
Shutdown Supply Current	I _{SHDN}	V _{EN} < 0.4V			1	μA
LED Current Deviation Matching	D _{LED}		-5		+5	%
OPT				150		°C
OPT Hysteresis				10		°C
Input High Voltage at EN	V _{IH}		2.5			V
Input Low Voltage at EN	V _{IL}				0.7	V

Specifications subject to changes without notice.

TYPICAL PERFORMANCE CHARACTERISTICS

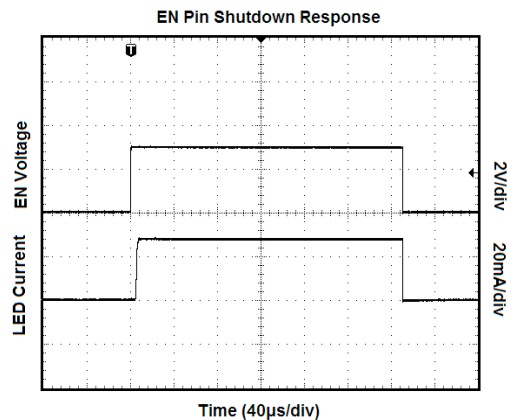
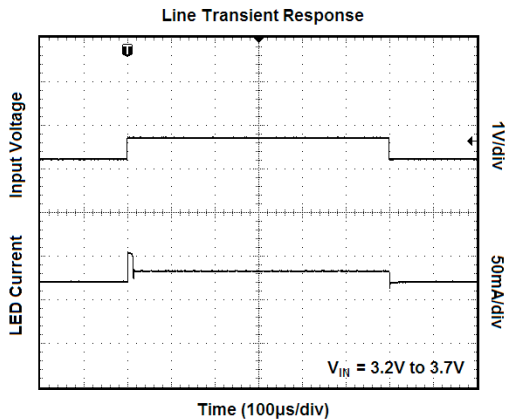
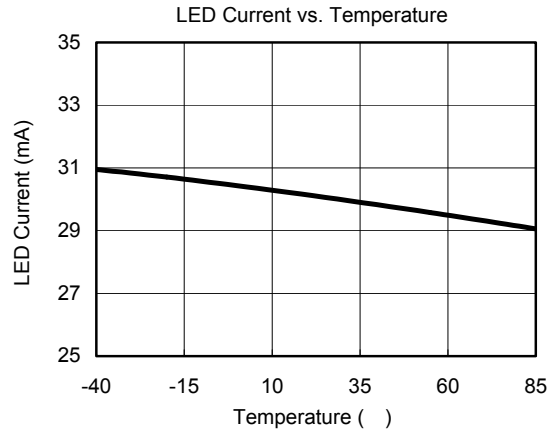
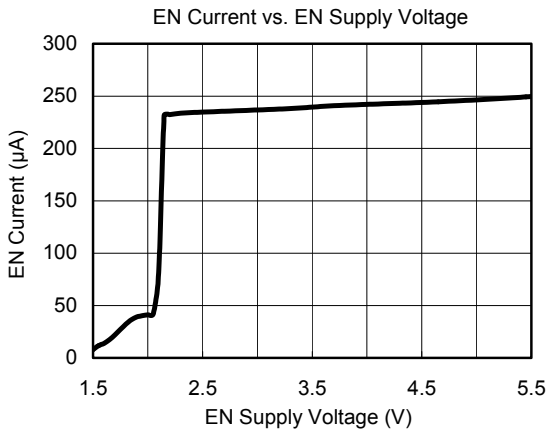
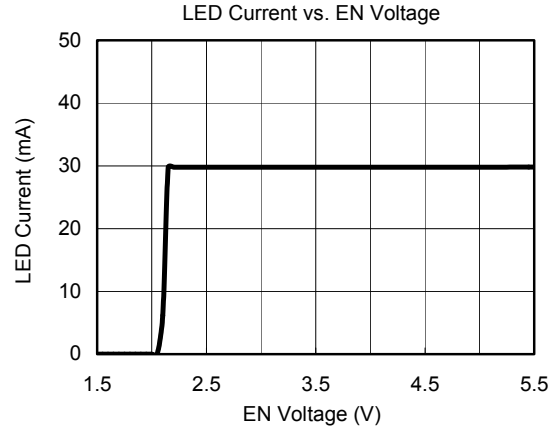
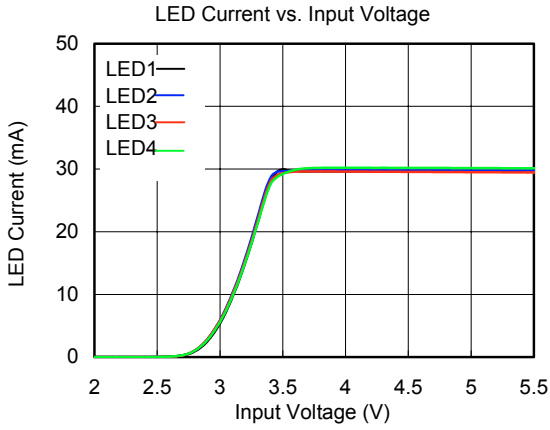

TYPICAL PERFORMANCE CHARACTERISTICS

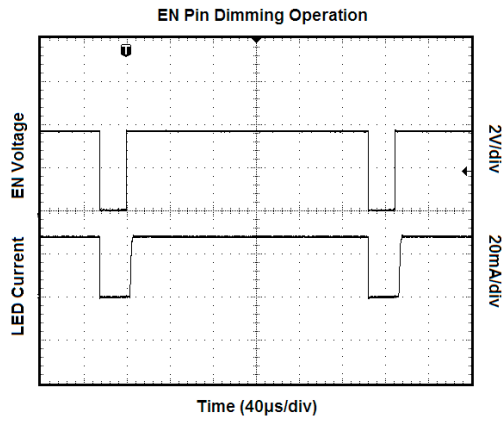

TYPICAL APPLICATION

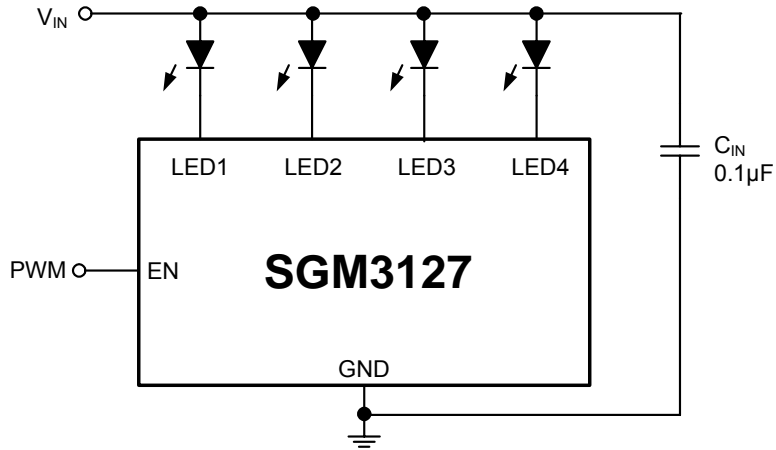

Figure 1. Application Circuit for Backlight

APPLICATIONS INFORMATION

The SGM3127 is a 4-Channel current source driver for white LEDs.

Enable Input

EN powers the input of the SGM3127. This IC provides an under voltage lockout (UVLO) function to prevent it from unstable issue when startup. The UVLO threshold of input falling voltage is set at 2.1V typically with a hysteresis 0.11V. Drive EN high to enable the device; drive EN low to disable the device. When driven high, EN draws 240µA to power the IC. Driving EN low forces LED1, LED2, LED3, and LED4 into a high-impedance state.

LED Current

SGM3127 provides a constant current for white LED. Figure 1 shows a typical application circuit for 4 white LEDs. Each channel supports up to 30mA current and regulates a constant current for uniform intensity. For keypad LED application, the all channels must be connected to LED as shown in Figure 2. In order to maintain LED constant current, the input voltage must provide the required LED forward voltage and current source dropout voltage. If the forward voltage of white LEDs is 3.3V, the input voltage should be higher than 3.4V to provide enough voltage headroom for maintaining constant brightness.

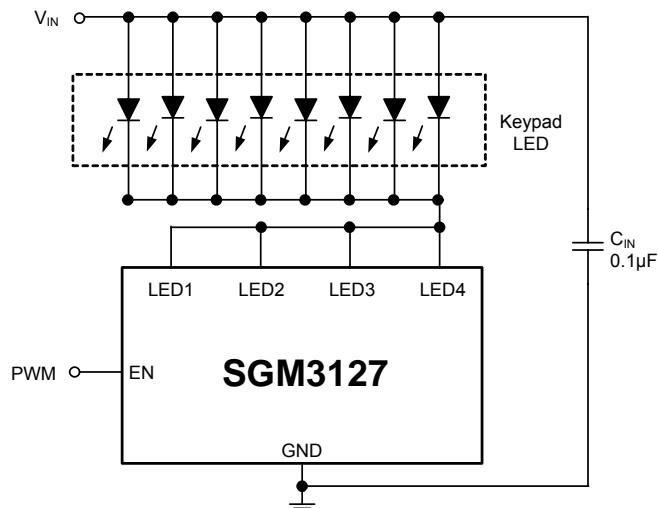

Figure 2. Application Circuit for Keypad

LED Brightness Dimming Control

For controlling the LED brightness, the SGM3127 can perform the dimming control by applying a PWM signal to EN pin. When an external PWM signal is connected to the EN pin, brightness of white LED is adjusted by the duty cycle. The average LED current is proportional to the PWM signal duty cycle. The magnitude of the PWM signal must be higher than the minimum level of enable input high level, in order to let the dimming control perform correctly, the suggested PWM frequency range is 10kHz to 200Hz.

Thermal Considerations

For continuous operation, do not exceed absolute maximum operation junction temperature 150°C. The maximum power dissipation depends on the thermal resistance of IC package, PCB layout, the rate of surroundings airflow and temperature difference between junctions and ambient. The maximum power dissipation can be calculated by following formula:

$$P_{D(MAX)} = (T_{J(MAX)} - T_A) / \theta_{JA}$$

Where $T_{J(MAX)}$ is the maximum operation junction temperature 150°C, T_A is the ambient temperature and the θ_{JA} is the junction to ambient thermal resistance.

For recommended operating conditions specification of SGM3127, where $T_{J(MAX)}$ is the maximum junction temperature of the die (150°C) and T_A is the maximum ambient temperature. The junction to ambient thermal resistance θ_{JA} is layout dependent. For SOT-23-6L package, the thermal resistance θ_{JA} is 250°C/W. The maximum power dissipation at $T_A = 25^\circ\text{C}$ can be calculated by following formula:

$$P_{D(MAX)} = (150^\circ\text{C} - 25^\circ\text{C}) / (250^\circ\text{C/W}) = 0.5\text{W}$$

PACKAGE OUTLINE DIMENSIONS

SOT-23-6L

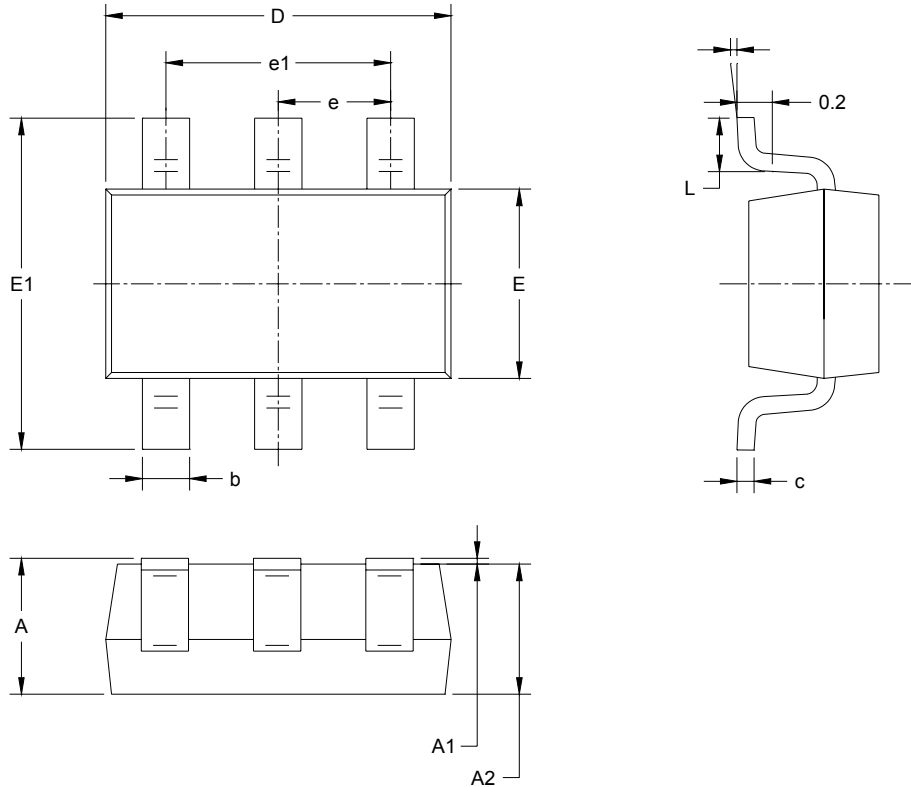

Symbol	Dimensions In Millimeters		Dimensions In Inches	
	Min	Max	Min	Max
A	1.050	1.250	0.041	0.049
A1	0.000	0.100	0.000	0.004
A2	1.050	1.150	0.041	0.045
b	0.300	0.500	0.012	0.020
c	0.100	0.200	0.004	0.008
D	2.820	3.020	0.111	0.119
E	1.500	1.700	0.059	0.067
E1	2.650	2.950	0.104	0.116
e	0.950 BSC		0.037 BSC	
e1	1.900 BSC		0.075 BSC	
L	0.300	0.600	0.012	0.024
θ	0°	8°	0°	8°

09/2009 REV. A.1

SGMICRO is dedicated to provide high quality and high performance analog IC products to customers. All SGMICRO products meet the highest industry standards with strict and comprehensive test and quality control systems to achieve world-class consistency and reliability.

For more information regarding SGMICRO Corporation and its products, please visit www.sg-micro.com