



# SPX1117

## 800mA Low Dropout Regulator

### FEATURES

- Guaranteed 800mA Output
- Three Terminal Adjustable Or Fixed 1.5V, 2.5V, 3V, 3.3V & 5V
- Very Low Quiescent Current
- Low Dropout Voltage Of 1.2 Volts At Full Load
- Extremely Tight Load And Line Regulation
- Very Low Temperature Coefficient
- Logic-Controlled Electronic Shutdown
- Internal Overcurrent Limiting & Thermal Overload Protection
- Surface Mount Package SOT-223, TO-252, TO-220, SOT-89, TO-263, & SO-8

### APPLICATIONS

- Portable/ Palm Top / Notebook Computers
- Battery Chargers
- Disk Drives
- Portable Consumer Equipment
- Portable Instrumentation
- SMPS Post-Regulator

### PRODUCT DESCRIPTION

The SPX1117 is a low power positive-voltage regulator designed to meet 800mA output current. This device is an excellent choice for use in battery-powered applications. The SPX1117 features very low quiescent current and very low dropout voltage of 1.2V at a full load and lower as output current decreases. SPX1117 is available as an adjustable or fixed 1.5V, 2.5V, 3.0V, 3.3V, and 5.0V output voltages.

The SPX1117 is offered in a 3-pin surface mount package SOT-223, TO-252, TO-220 and TO-263. The output capacitor of 10 $\mu$ F or larger is needed for output stability of SPX1117 as required by most of the other regulator circuits.

### PIN CONNECTIONS

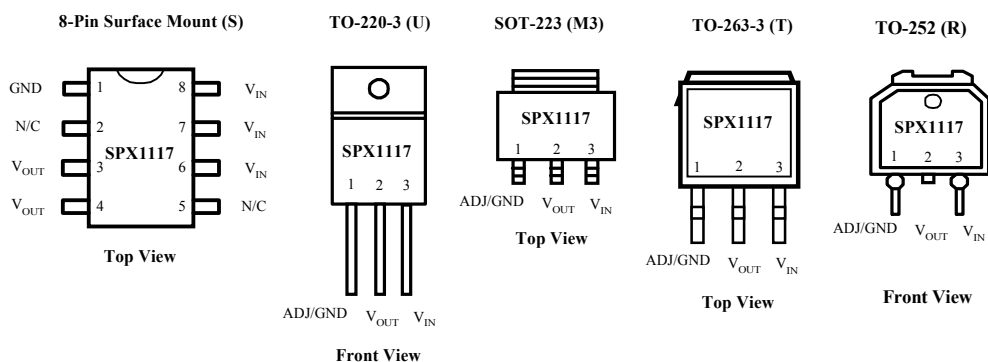

## ABSOLUTE MAXIMUM RATINGS

Power Dissipation.....	Internally Limited
Lead Temp. (Soldering, 5 Seconds) .....	260°C
Storage Temperature Range .....	-65° to +150°C
Operating Junction Temperature Range	
SPX1117.....	-40C° to +125°C

Input Supply Voltage .....	-20V to +20V
ESD Rating .....	2KV Min

**ELECTRICAL CHARACTERISTICS** at  $V_{IN} = V_{OUT} + 1$ ,  $T_a = 25^\circ\text{C}$ ,  $C_L = 3.3\mu\text{f}$ , unless otherwise specified. Limits in **Boldface** apply over the full operating temperature range.

Parameter	Conditions	Typ	SPX1117		Units
			Min	Max	
<b>1.5V Version</b>					
Output Voltage	$I_{OUT} = 10\text{mA}$ , $V_{IN} = 4.85\text{V}$ $0 \leq I_{OUT} \leq 800\text{mA}$ , $4.25 \leq V_{IN} \leq 10\text{V}$	1.500	1.485 <b>1.470</b>	1.515 <b>1.530</b>	V
<b>2.5V Version</b>					
Output Voltage	$I_{OUT} = 10\text{mA}$ , $V_{IN} = 4.85\text{V}$ $0 \leq I_{OUT} \leq 800\text{mA}$ , $4.25 \leq V_{IN} \leq 10\text{V}$	2.500	2.475 <b>2.450</b>	2.525 <b>2.550</b>	V
<b>3.0V Version</b>					
Output Voltage	$I_{OUT} = 10\text{mA}$ , $V_{IN} = 4.85\text{V}$ $0 \leq I_{OUT} \leq 800\text{mA}$ , $4.75 \leq V_{IN} \leq 10\text{V}$	3.000	2.970 <b>2.940</b>	3.030 <b>3.060</b>	V
<b>3.3V Version</b>					
Output Voltage	$I_{OUT} = 10\text{mA}$ , $V_{IN} = 5.0\text{V}$ $0 \leq I_{OUT} \leq 800\text{mA}$ , $4.75 \leq V_{IN} \leq 10\text{V}$	3.300	3.267 <b>3.234</b>	3.333 <b>3.366</b>	V
<b>5.0V Version</b>					
Output Voltage	$I_{OUT} = 10\text{mA}$ , $V_{IN} = 7.0\text{V}$ $0 \leq I_{OUT} \leq 800\text{mA}$ , $6.50 \leq V_{IN} \leq 12\text{V}$	5.000	4.950 <b>4.900</b>	5.050 <b>5.100</b>	V
<b>All Output Options</b>					
Reference Voltage	$I_{OUT} = 10\text{mA}$ , $(V_{IN} - V_{OUT}) = 2\text{V}$ $10 \leq I_{OUT} \leq 800\text{mA}$ , $1.4 \leq (V_{IN} - V_{OUT}) \leq 10\text{V}$	1.250	1.238 1.225	1.262 1.270	V
Output Voltage Temperature Stability	(Note 1)			<b>0.05</b>	%
Line Regulation	$4.50\text{V} \leq V_{IN} \leq 12\text{V}$ , $V_{OUT} = 3.00$ , $I_{OUT} = 0$ $4.80\text{V} \leq V_{IN} \leq 12\text{V}$ , $V_{OUT} = 3.30$ , $I_{OUT} = 0$ $6.50\text{V} \leq V_{IN} \leq 15\text{V}$ , $V_{OUT} = 5.00$ , $I_{OUT} = 0$	1.00 1.00 1.00		7.00 7.00 10.00	mV
Load Regulation	$0 \leq I_{OUT} \leq 800\text{mA}$ , $V_{IN} = 4.50\text{V}$ , $V_{OUT} = 3.00$ $0 \leq I_{OUT} \leq 800\text{mA}$ , $V_{IN} = 4.80\text{V}$ , $V_{OUT} = 3.30$ $0 \leq I_{OUT} \leq 800\text{mA}$ , $V_{IN} = 6.50\text{V}$ , $V_{OUT} = 5.00$	1.00 1.00 1.00		12.00 12.00 15.00	mV
Dropout Voltage (Note 2)	$I_L = 100\text{mA}$ $I_L = 500\text{mA}$ $I_L = 800\text{mA}$	1.00 1.05 1.10		1.10 1.15 1.20	V
Quiescent Current	$4.25\text{V} \leq V_{IN} \leq 6.5\text{V}$	5.00		10.00	mA
Current Limit	$(V_{IN} - V_{OUT}) = 5\text{V}$	1000		1200	mA
Thermal Regulation	25°C, 30mS Pulse	0.01		0.1	%/W
Ripple Rejection	$f_{RIPPLE} = 120\text{Hz}$ , $(V_{in} - V_{OUT}) = 3\text{V}$ , $V_{RIPPLE} = 1\text{V}_{p-p}$	60		75	dB
Long Term Stability	125°C, 1000Hrs			0.03	%
RMS Output Noise	% of $V_{out}$ , $10\text{Hz} \leq f \leq 10\text{kHz}$			0.003	%
Thermal Resistance	Junction to case, at tab			15	°C/W°

**Note 1:** Output temperature coefficient is defined as the worst case voltage change divided by the total temperature range

**Note 2:** Dropout voltage is defined as the input to output differential at which the output voltage drops 100mV below its nominal value measured at 1V differential at very low values of programmed output voltage, the minimum input supply voltage of 2V ( 2.3V over temperature) must be taken into account.

**Note 3:** Thermal regulation is defined as the change in output voltage at a time T after a change in power dissipation is applied. excluding load or line regulation effect.

## APPLICATION NOTES EXTERNAL CAPACITOR

To ensure the stability of the SPX1117 an output capacitor of at least 10µF (tantalum) or 50µF (aluminum) is required. The value may change based on the application requirements on the output load or temperature range. The capacitor equivalent series resistance (ESR) will effect the SPX1117 stability. The value of ESR can vary from the type of capacitor used in the applications. The recommended value for ESR is 0.5Ω. The output capacitance could increase in size to above the minimum value. The larger value of output capacitance as high as 100µF can improve the load transient response.

## SOLDERING METHODS

The SPX1117 SOT-223 package is designed to be compatible with infrared reflow or vapor-phase reflow soldering techniques. During soldering the non-active or mildly active fluxes may be used. The SPX1117 die is attached to the heatsink lead which exits opposite the input, output, and ground pins.

Hand soldering and wave soldering should be avoided since these methods can cause damage to the package with excessive thermal gradients on the package. The SOT-223 recommended soldering method are as follows: vapor phase reflow and infrared reflow with the component preheated to within 65°C of the soldering temperature range.

## THERMAL CHARACTERISTICS

The thermal resistance of SPX1117 is 15°C/W from junction to tab and 31 °C/W from tab to ambient for a total of 46 °C/W from junction to ambient. The SPX1117 features the internal thermal limiting to protect the device during overload conditions. Special care needs to be taken during continuous load conditions the maximum junction temperature does not exceed 125 °C.

Taking the FR-4 printed circuit board and 1/16 thick with 1 ounce copper foil as an experiment (fig.1 & fig.2), the PCB material is effective at transmitting heat with the tab attached to the pad area and a ground plane layer on the backside of the substrate. Refer to table 1 for the results of the experiment.

The thermal interaction from other components in the application can effect the thermal resistance of the SPX1117. The actual thermal resistance can be determined with experimentation. SPX1117 power dissipation is calculated as follows:

$$P_D = (V_{IN} - V_{OUT})(I_{OUT})$$

Maximum Junction Temperature range:

$$T_J = T_{\text{ambient (max)}} + P_D * \text{thermal resistance (Junction-to-ambient)}$$

Maximum Junction temperature must not exceed the 125°C.

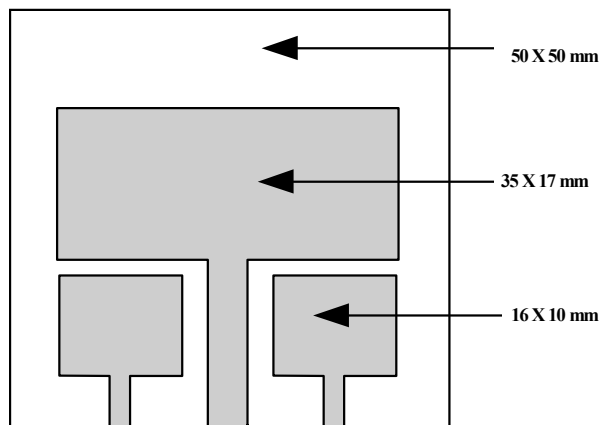
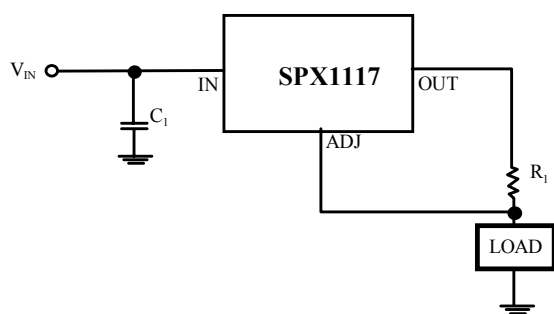

Fig. 1. Substrate Layout for SOT-223

Table 1.

TOTAL PC BOARD AREA	TOPSIDE COPPER AREA	BACKSIDE COPPER AREA	THERMAL RESISTANCE JUNCTION TO AMBIENT
2500mm	2500mm	2500mm	46°C/W°
2500mm	1250mm	2500mm	47°C/W°
2500mm	950mm	2500mm	49°C/W°
2500mm	2500mm	0	51°C/W°
2500mm	1800mm	0	53°C/W°
1600mm	600mm	1600mm	55°C/W°
2500mm	1250mm	0	58°C/W°
2500mm	915mm	0	59°C/W°
1600mm	600mm	0	67°C/W°
900mm	240mm	900mm	72°C/W°
900mm	240mm	0	85°C/W°



800mA Current output

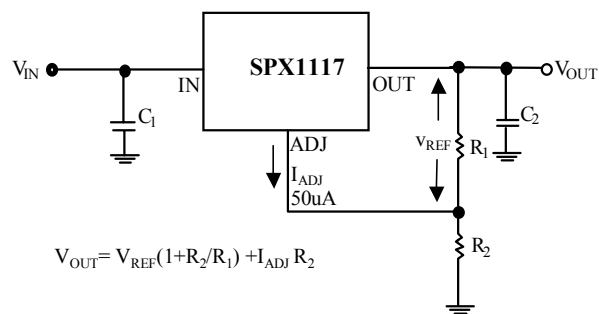

$$V_{OUT} = V_{REF}(1 + R_2/R_1) + I_{ADJ} R_2$$

Typical Adjustable Regulator

PACKAGE DRAWING  
TO-263-3L (T)

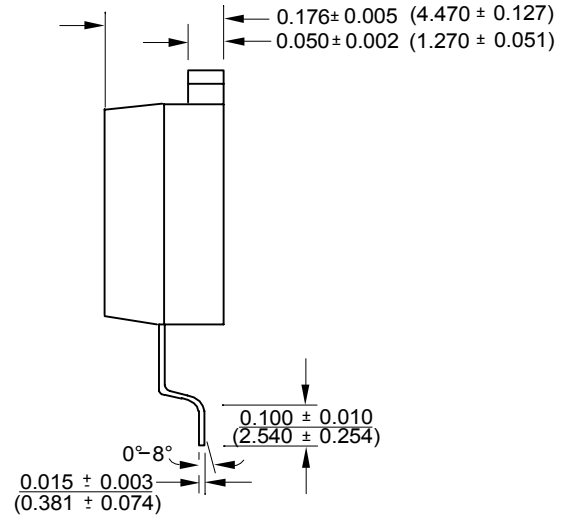
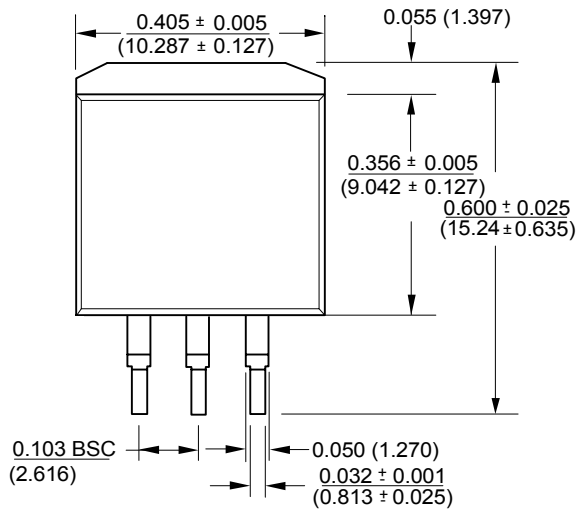

PACKAGE DRAWING  
SOT-223-3L (M3)

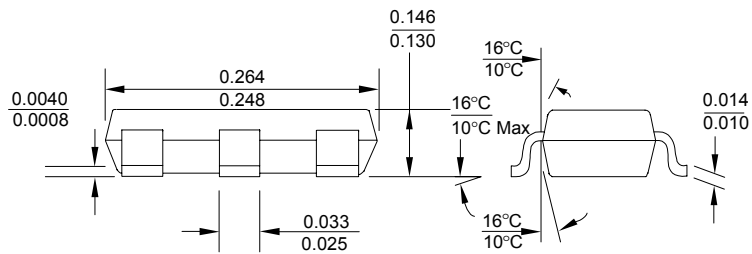
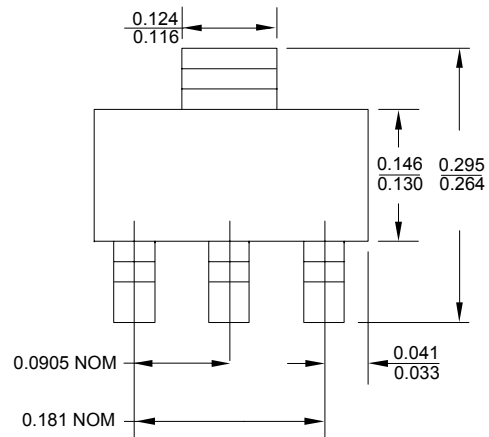

PACKAGE DRAWING  
TO-220-3L (U)

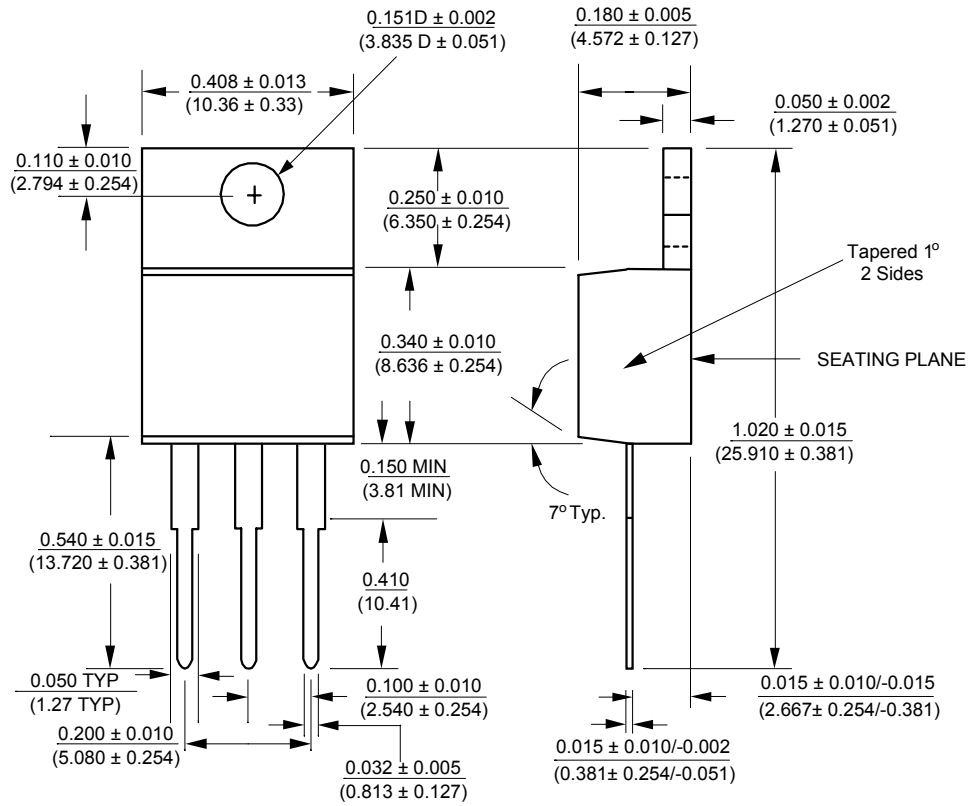

PACKAGE DRAWING  
8-PIN SOIC (S)

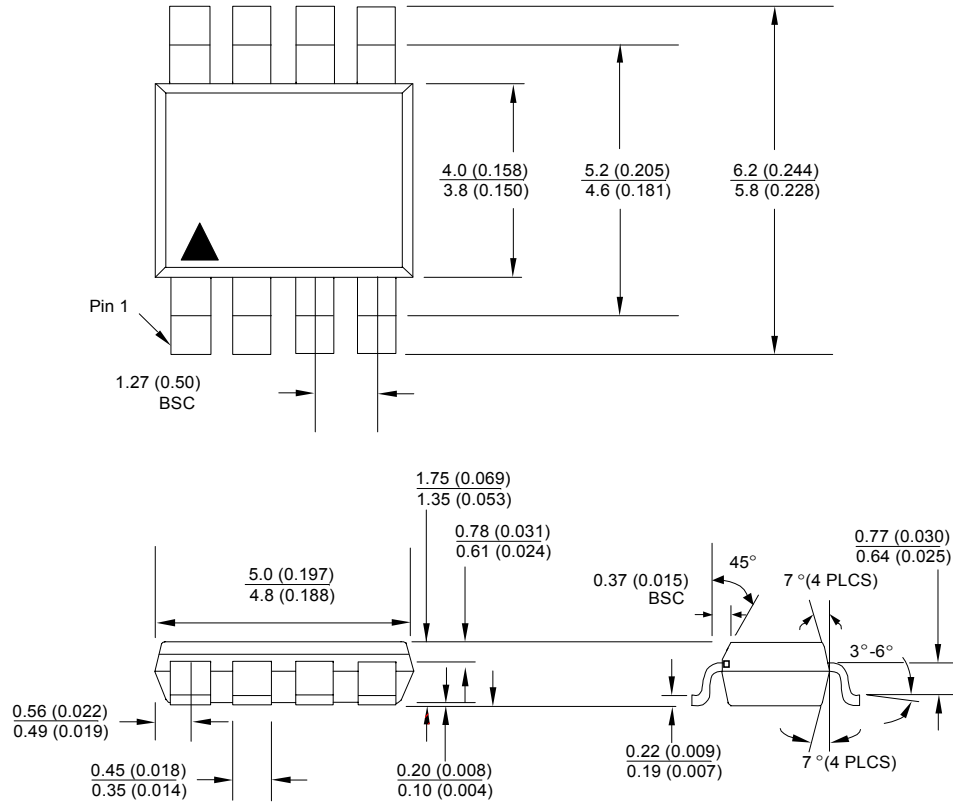



## PACKAGE DRAWING TO-252-3L (R)

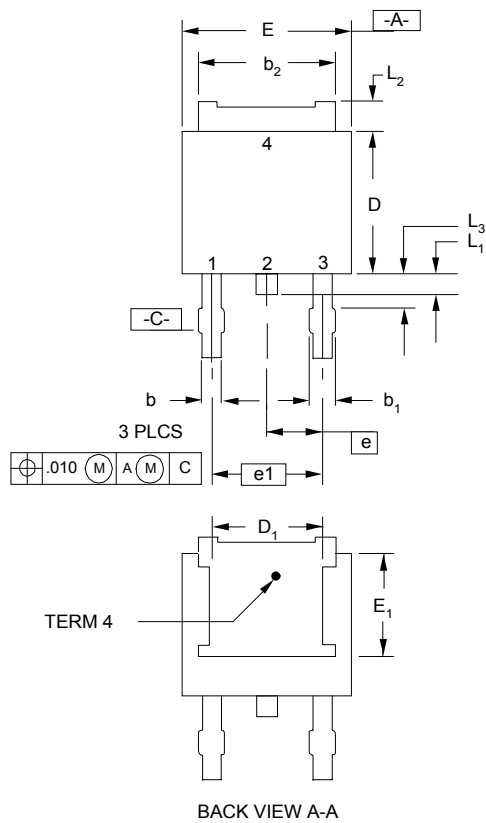

### NOTES

1. Refer To Applicable Symbol List.
2. Dimensions And Tolerancing Per Ansi Y14.5m - 1982.
3. Lead Dimension Uncontrolled In L<sub>3</sub>.
4. Tab Contour Optional Within Dim. b<sub>2</sub> & L<sub>2</sub> And E<sub>1</sub> & D<sub>1</sub>
  5. D<sub>1</sub> & E<sub>1</sub> Establishes A Minimum Mounting Surface for Terminal 4.
6. L is the Termal Length for Soldering.
7. Controlling Dimension: Inch
8. 2 Mils Suggested For Postive Contact At Mounting.

SYMBOL	INCHES		MM		NOTE
	MIN	MAX	MIN	MAX	
A	0.086	0.094	2.184	2.3876	
A1	0.035	0.045	0.889	1.143	
b	0.025	0.035	0.635	0.889	
b1	0.300	0.045	7.620	1.143	
b2	0.205	0.215	5.207	5.461	4
c	0.018	0.023	0.457	0.5842	
c1	0.018	0.023	0.457	0.5842	
D	0.235	0.245	5.969	6.223	
D1	0.170	-	4.318	-	4,5
E	0.250	0.265	6.350	6.731	
E1	0.170	-	4.318	-	4,5
e	0.098		2.489		
e1	0.180		4.572		
H	0.370	0.410	9.398	10.414	
L	0.020	-	0.508	-	6
L1	0.025	0.040	0.635	1.016	
L2	0.035	0.050	0.889	1.270	4
L3	0.045	0.060	1.143	1.524	3

## ORDERING INFORMATION

Ordering No.	Precision	Output Voltages	Packages
SPX1117U	1%	Adj	3 Lead TO-220
SPX1117U-1.5	1%	1.5V	3 Lead TO-220
SPX1117U-2.5	1%	2.5V	3 Lead TO-220
SPX1117U-3.0	1%	3.0V	3 Lead TO-220
SPX1117U-3.3	1%	3.3V	3 Lead TO-220
SPX1117U-5.0	1%	5.0V	3 Lead TO-220
SPX1117T	1%	Adj	3 Lead TO-263
SPX1117T-1.5	1%	1.5V	3 Lead TO-263
SPX1117T-2.5	1%	2.5V	3 Lead TO-263
SPX1117T-3.0	1%	3.0V	3 Lead TO-263
SPX1117T-3.3	1%	3.3V	3 Lead TO-263
SPX1117T-5.0	1%	5.0V	3 Lead TO-263
SPX1117M3	1%	Adj	3 Lead TO-223
SPX1117M3-1.5	1%	1.5V	3 Lead TO-223
SPX1117M3-2.5	1%	2.5V	3 Lead TO-223
SPX1117M3-3.0	1%	3.0V	3 Lead TO-223
SPX1117M3-3.3	1%	3.3V	3 Lead TO-223
SPX1117M3-5.0	1%	5.0V	3 Lead TO-223
SPX1117S	1%	Adj	3 Lead TO-220
SPX1117S-1.5	1%	1.5V	8 Lead SOIC
SPX1117S-2.5	1%	2.5V	8 Lead SOIC
SPX1117S-3.0	1%	3.0V	8 Lead SOIC
SPX1117S-3.3	1%	3.3V	8 Lead SOIC
SPX1117S-5.0	1%	5.0V	8 Lead SOIC
SPX1117R	1%	Adj	3 Lead TO-252
SPX1117R-1.5	1%	1.5V	3 Lead TO-252
SPX1117R-2.5	1%	2.5V	3 Lead TO-252
SPX1117R-3.0	1%	3.0V	3 Lead TO-252
SPX1117R-3.3	1%	3.3V	3 Lead TO-252
SPX1117R-5.0	1%	5.0V	3 Lead TO-252



SIGNAL PROCESSING EXCELLENCE

### Sipex Corporation

**Headquarters and Main Offices:**

22 Linnell Circle  
Billerica, MA 01821  
TEL: (978) 667-8700  
FAX: (978) 670-9001  
e-mail: sales@sipex.com

233 South Hillview Drive  
Milpitas, CA 95035  
TEL: (408) 935-7600  
FAX: (408) 934-7500

Sipex Corporation reserves the right to make changes to any products described herein. Sipex does not assume any liability arising out of the application or use of any product or circuit described hereing; neither does it convey any license under its patent rights nor the rights of others.