

### Features

- Real-time vehicle tracking system based on GPRS/GSM/GNSS. The vehicle location coordinates are acquired using FASTRAX GPS/GLONASS module and sent over GPRS to the web server-based fleet tracking application
- Web GUI-based application based on API's provided by third party map provider "Open Street Maps" can monitor up to 10 vehicles, their known location and status
- Car lift alarm for anti-theft feature ( MEMS-based)
- Black box functionality: in case of vehicle crash (detected using MEMS), vehicle status and location parameters are stored in the micro SD card and SMS. In all other cases any alarm notification is through web-based GUI
- Tamper and panic detection, and alarm
- Local graphic display of information such as vehicle status, location coordinates, speed, distance covered, GPS strength, GSM signal strength, time and date
- Ability to send alert message from web application to be show on tracking system display
- Buzzer on vehicle unit for alarm indication
- On-board user switch for different actions
- RoHS compliant

### Description

The STEVAL-IEG001V1 is a smart vehicle tracking system reference design based on GPS-GLONASS/GSM-GPRS. The system is built around the Cortex-M3 STM32F20x microcontroller series. Today, tracking and navigation systems for vehicles are extensively used all over the world by public transportation units, fleet owners and individuals, and are



essential parts of vehicle telematics systems. The design consists of a vehicle unit (to be installed inside the vehicle) and remote web server application where the vehicle status and movement information may be viewed in an intuitive way on the map. The vehicle unit is built around the Cortex-M3 STM32F20x microcontroller, Fastrax GNSS (TESEO II) module and a SAGEM GSM/GPRS module. The vehicle unit gathers the GPS/GLONASS information on geographic coordinates, time, date, speed, in-journey distance traveled and satellites fixed, and sends this information over GPRS to the web server application. The web application shows the current location and status information of the vehicle on open street maps. The same information is displayed locally on the graphical LCD display. This unit also consists of MEMS sensors LIS331DLH 3-axis accelerometer, and L3G4200D yaw/pitch/roll gyroscope. This unit also serves as a theft detection unit and senses car lift using MEMS. In case of vehicle crash (detected using MEMS), the vehicle status and location parameters are logged in the micro SD card, and the same information is sent to the administrator over SMS, thereby providing black-box functionality.

# 1 Schematic diagrams

Figure 1.  $\mu$ SD connections

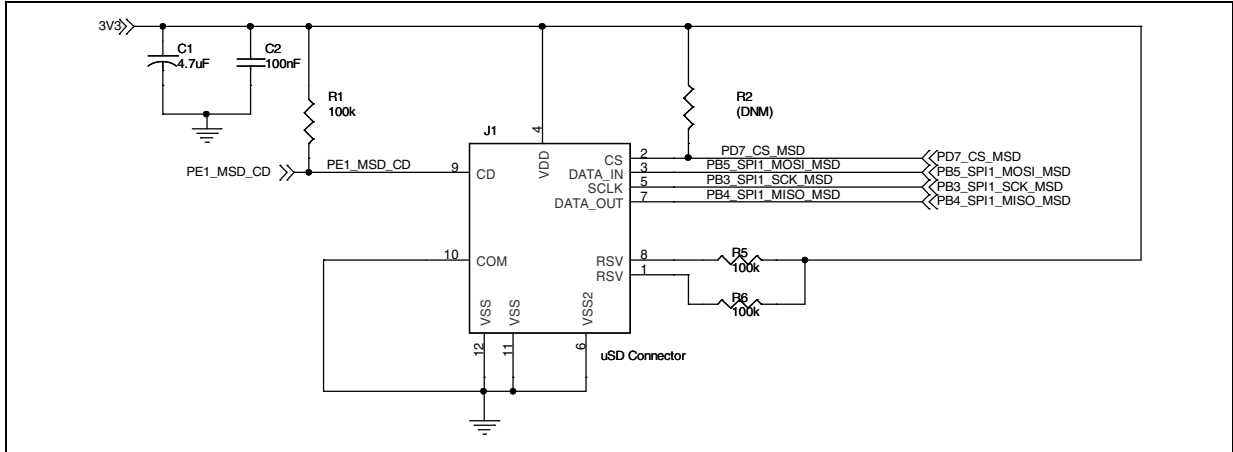

Figure 2. IrDa transceiver

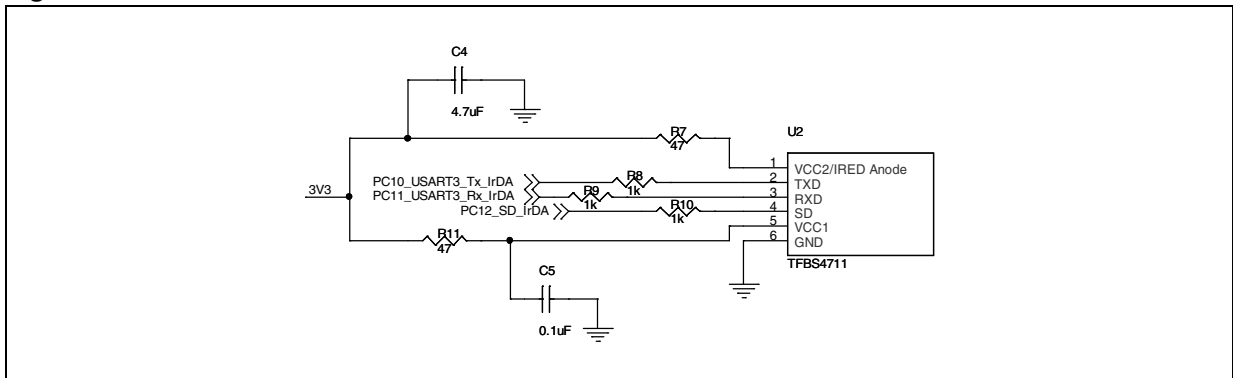

Figure 3. EEPROM section

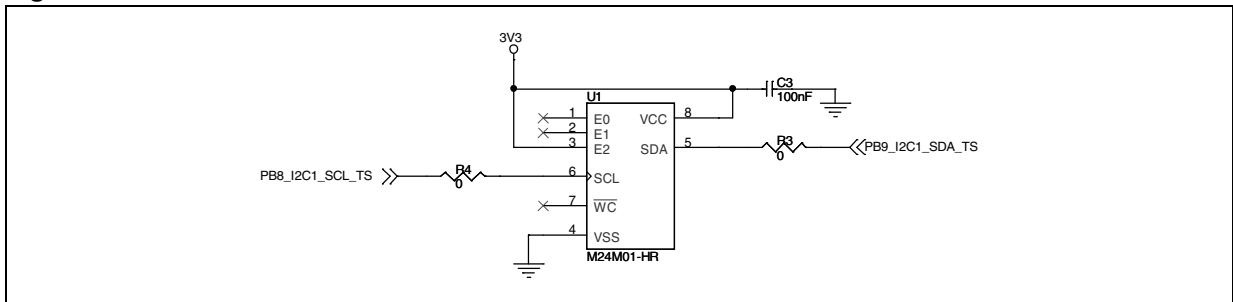

Figure 4. LCD connector on VTS motherboard

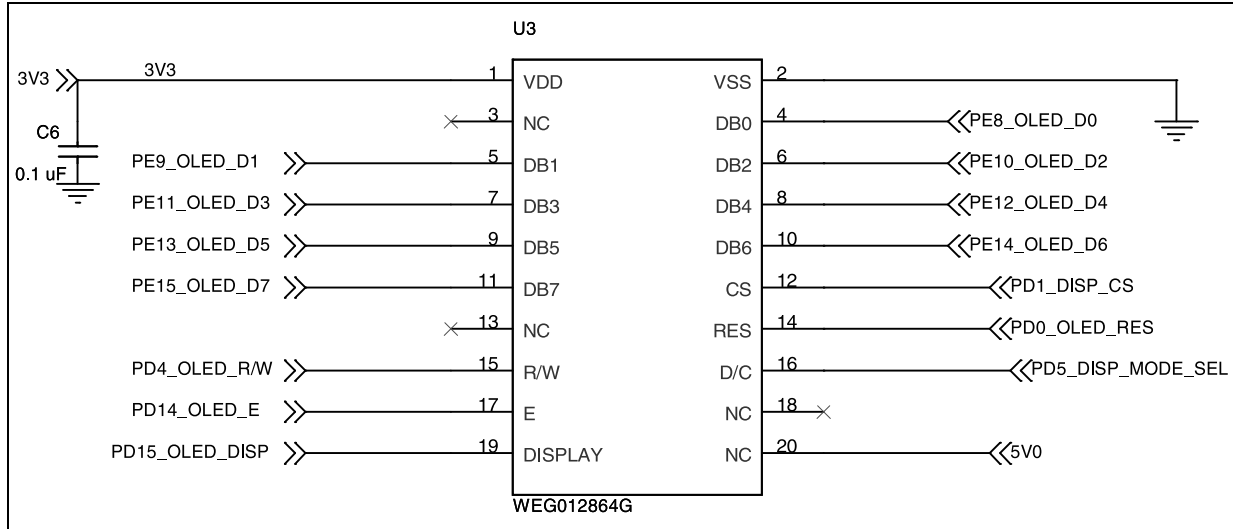

Figure 5. Graphical LCD daughter card

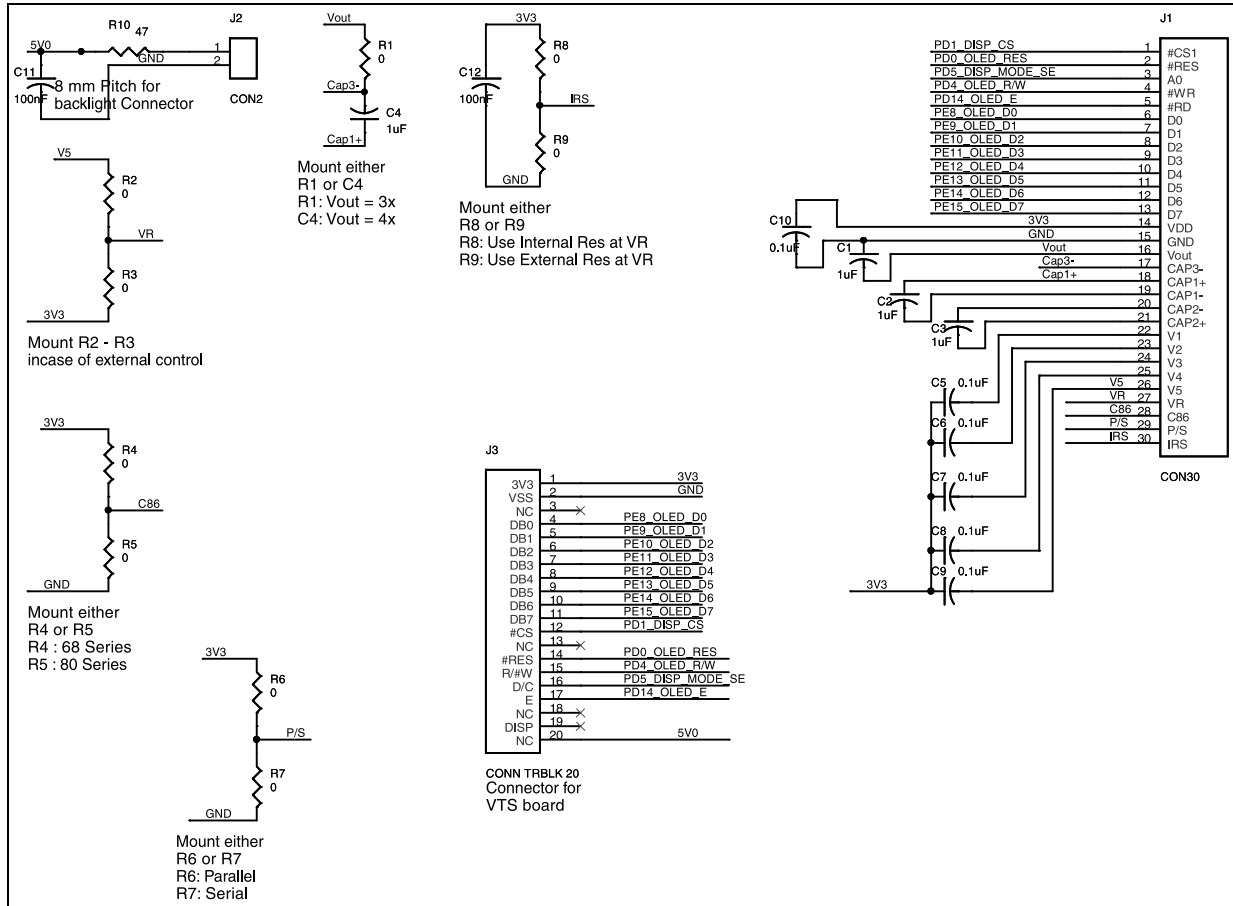



Figure 8. SIM card section

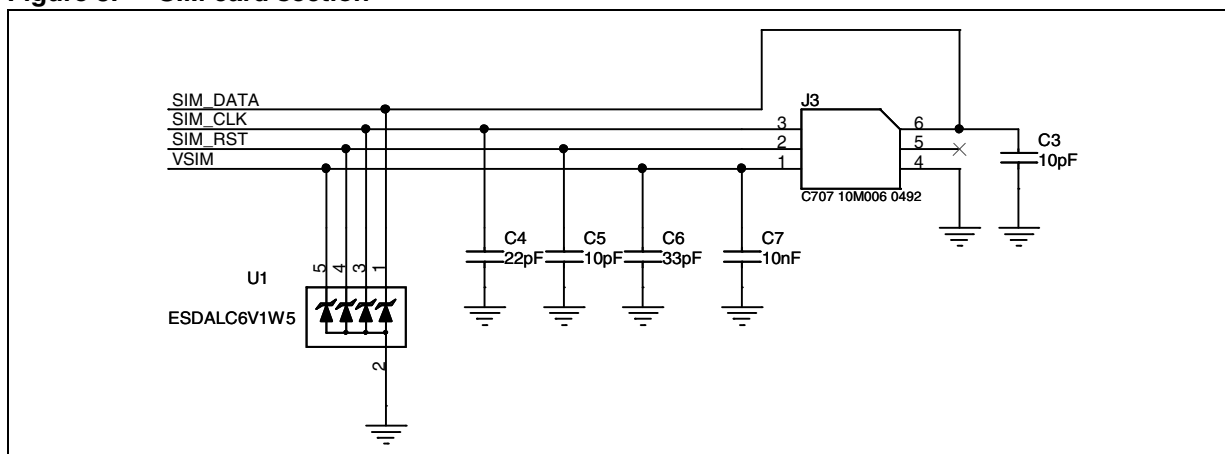

Figure 9. Compatibility between STM32F10x and STM32F20x

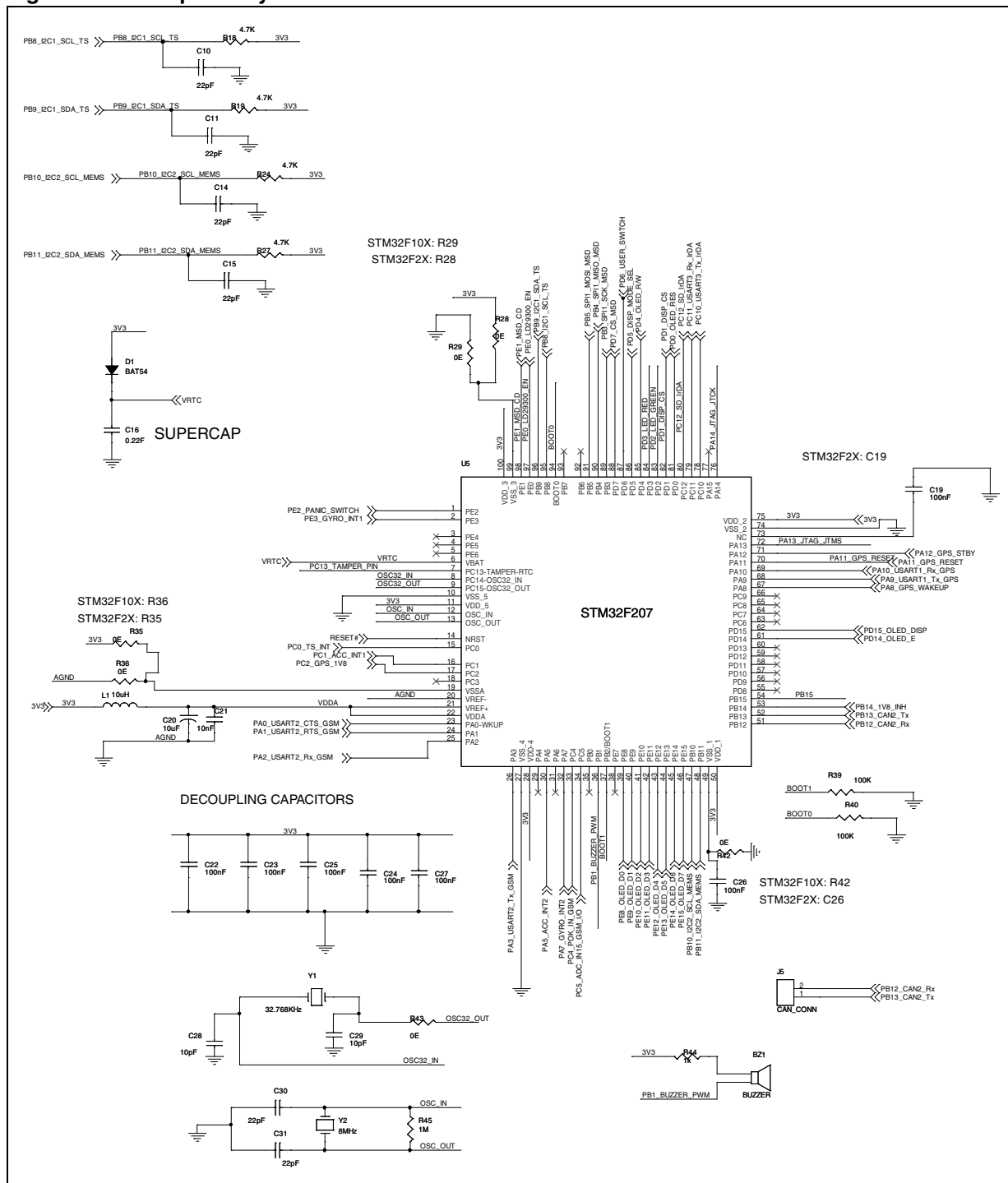

Figure 10. Switch section

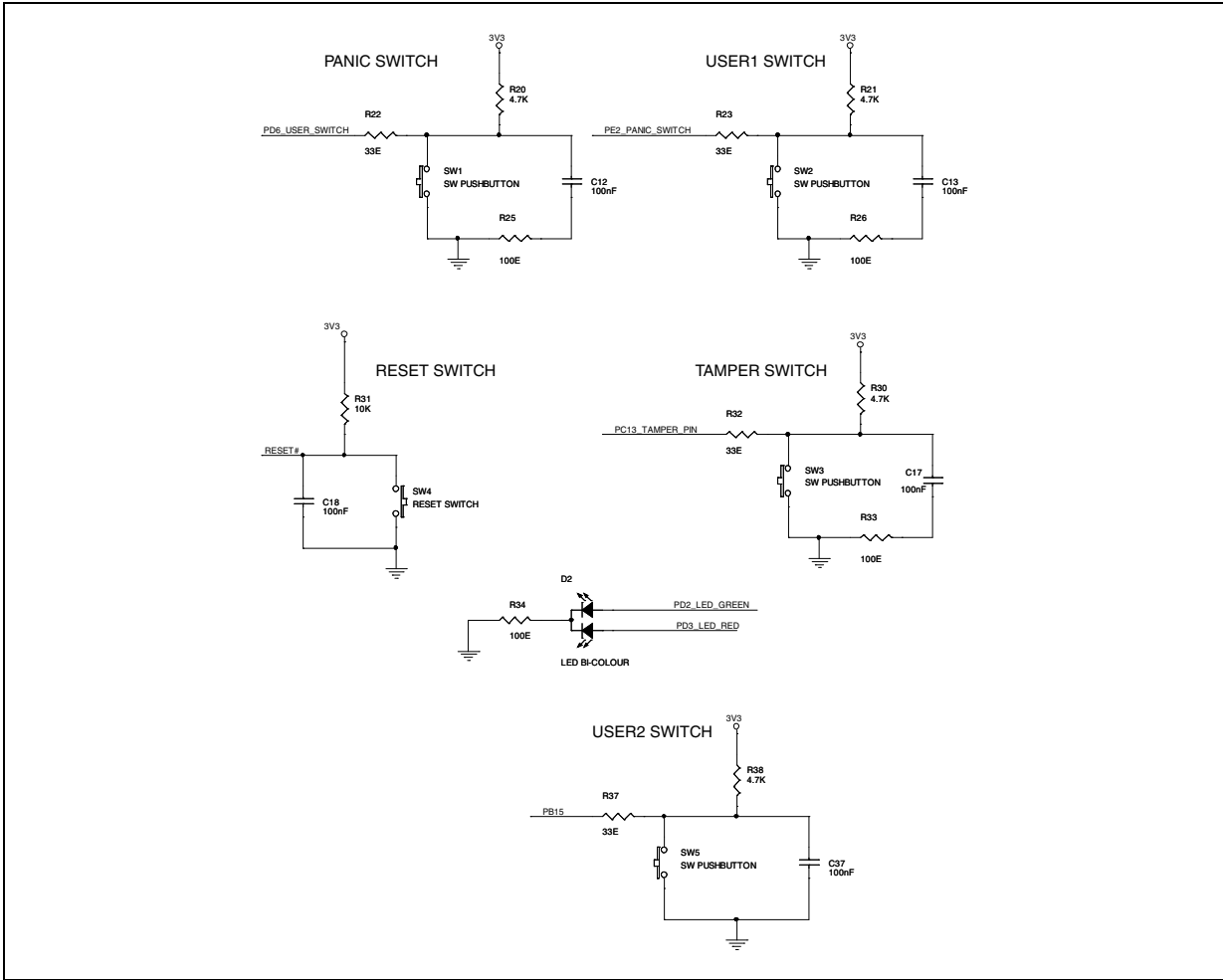

Figure 11. SWD section

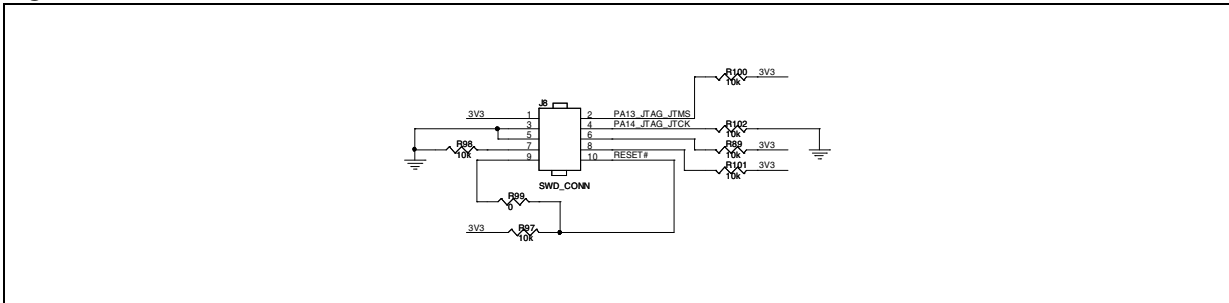

Figure 12. 5 V regulator

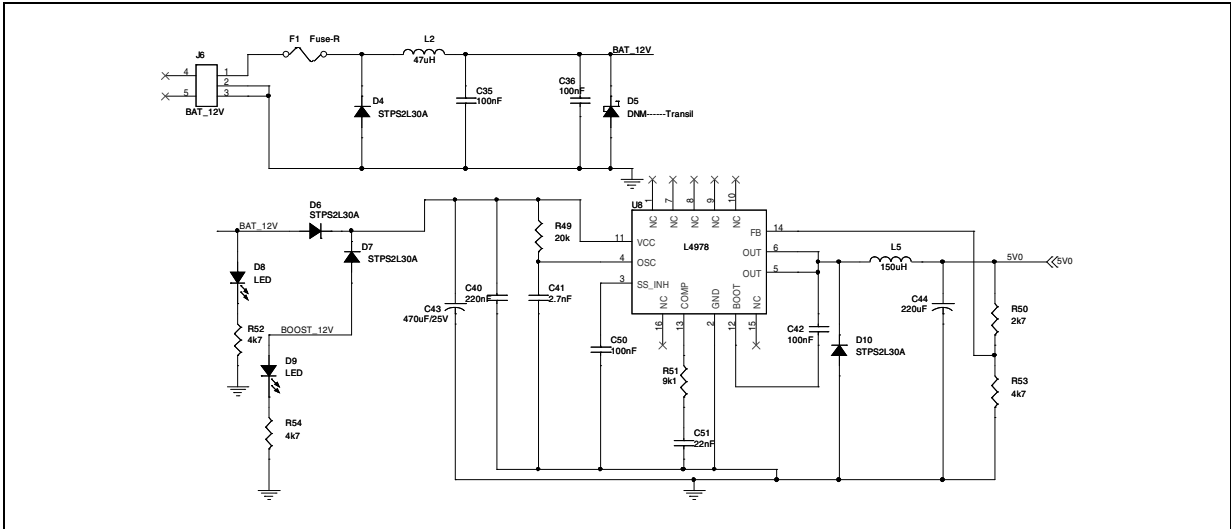

Figure 13. L6924D battery charger

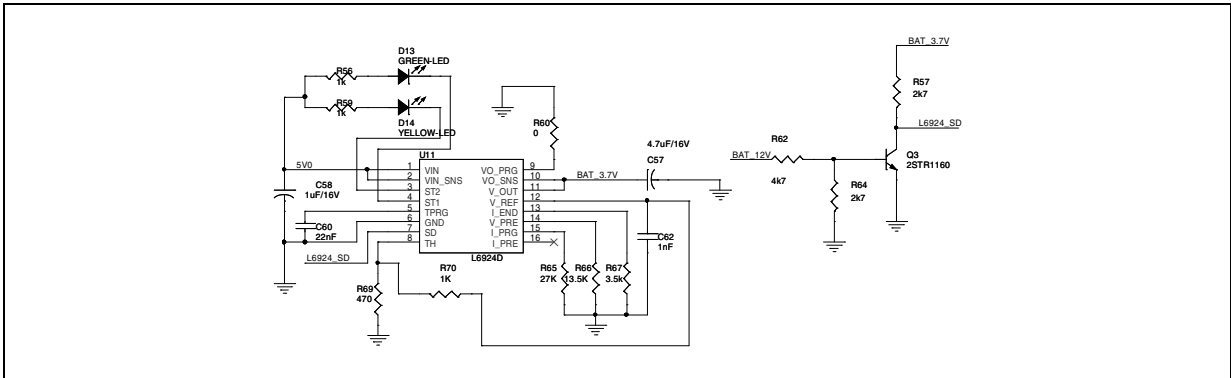

Figure 14. Voltage regulators

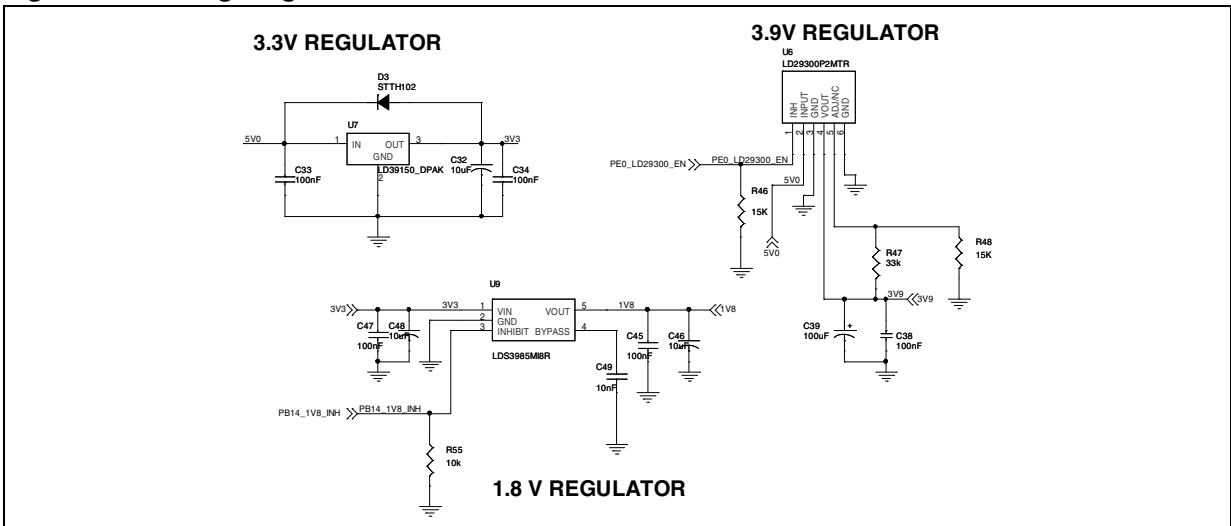



Figure 15. Boost using STLDC08

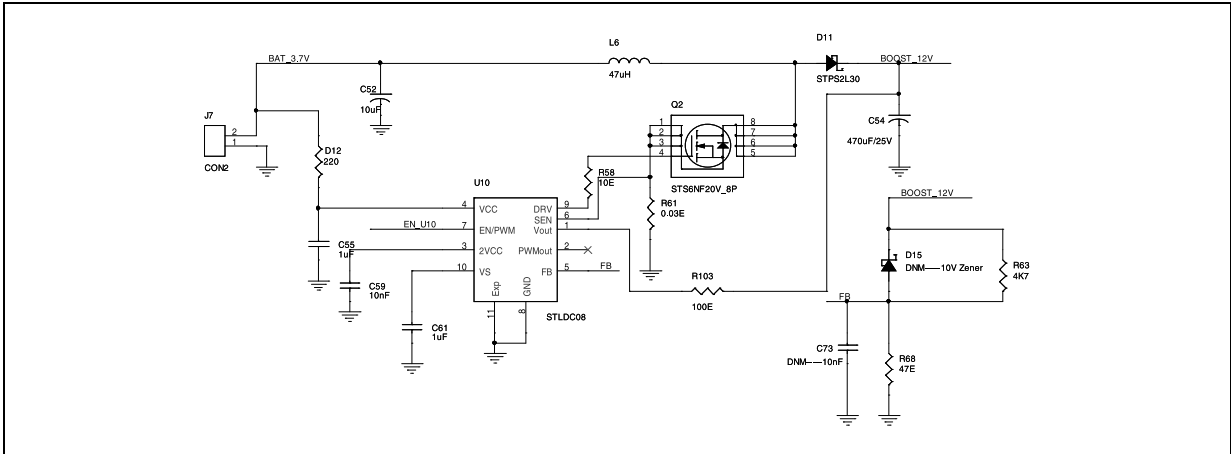

Figure 16. Battery protection and boost/charger synchronization

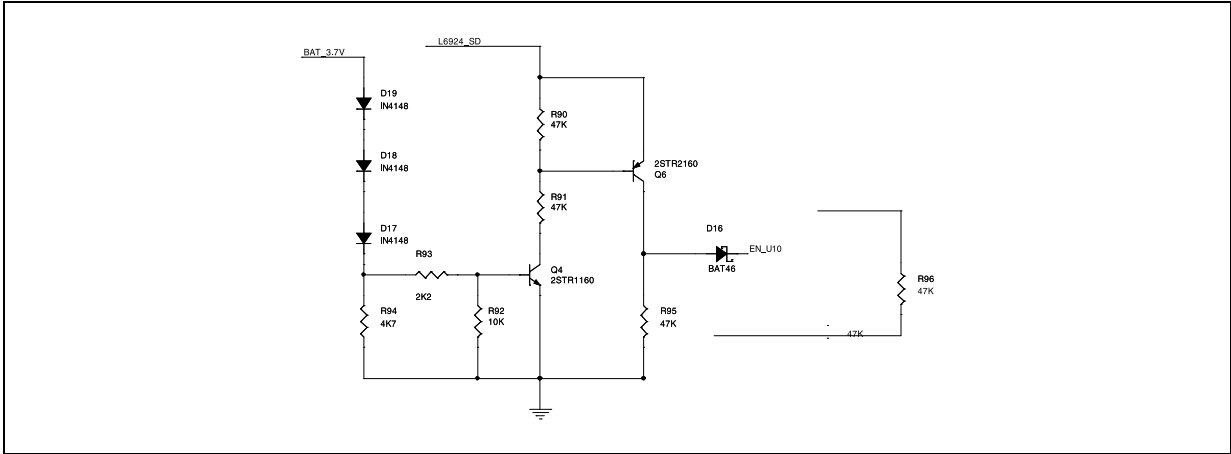

Figure 17. Gyroscope section

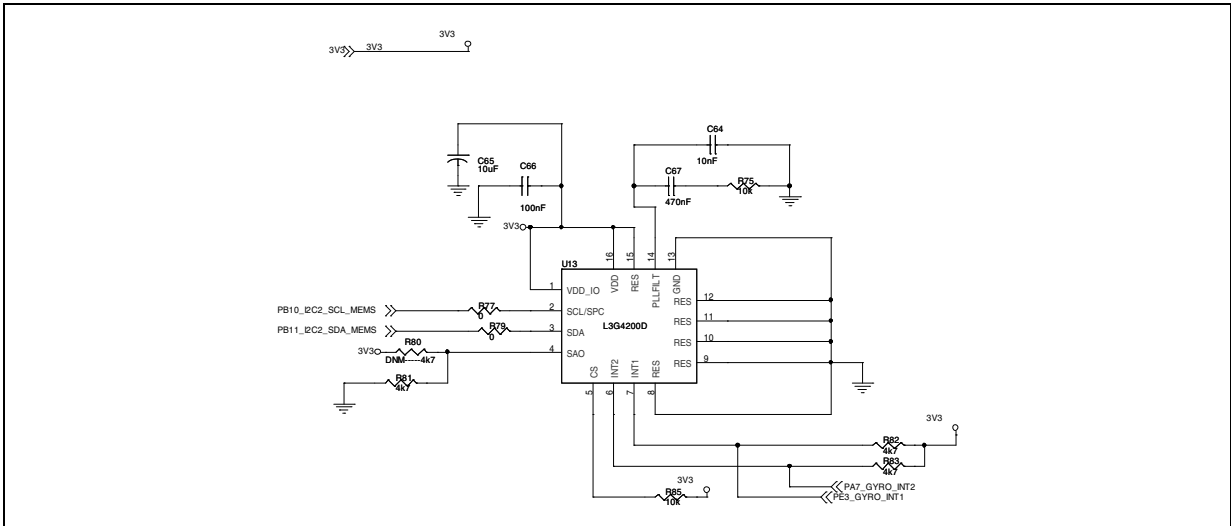

Figure 18. Temperature sensor

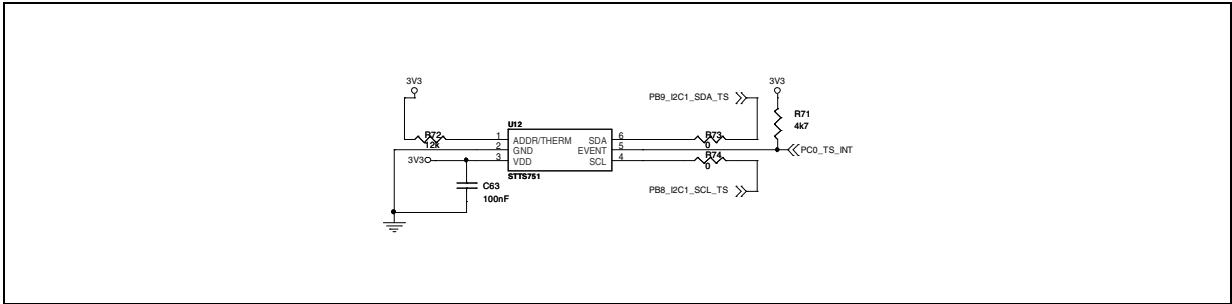
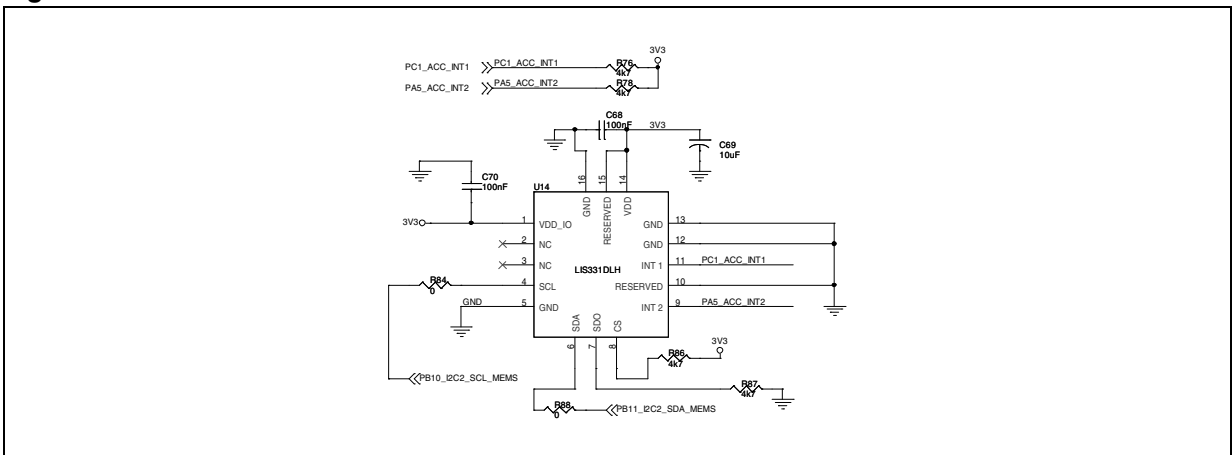

Figure 19. Accelerometer section



## 2 Revision history

Table 1. Document revision history

Date	Revision	Changes
25-Oct-2012	1	Initial release.

**Please Read Carefully:**

Information in this document is provided solely in connection with ST products. STMicroelectronics NV and its subsidiaries ("ST") reserve the right to make changes, corrections, modifications or improvements, to this document, and the products and services described herein at any time, without notice.

All ST products are sold pursuant to ST's terms and conditions of sale.

Purchasers are solely responsible for the choice, selection and use of the ST products and services described herein, and ST assumes no liability whatsoever relating to the choice, selection or use of the ST products and services described herein.

No license, express or implied, by estoppel or otherwise, to any intellectual property rights is granted under this document. If any part of this document refers to any third party products or services it shall not be deemed a license grant by ST for the use of such third party products or services, or any intellectual property contained therein or considered as a warranty covering the use in any manner whatsoever of such third party products or services or any intellectual property contained therein.

**UNLESS OTHERWISE SET FORTH IN ST'S TERMS AND CONDITIONS OF SALE ST DISCLAIMS ANY EXPRESS OR IMPLIED WARRANTY WITH RESPECT TO THE USE AND/OR SALE OF ST PRODUCTS INCLUDING WITHOUT LIMITATION IMPLIED WARRANTIES OF MERCHANTABILITY, FITNESS FOR A PARTICULAR PURPOSE (AND THEIR EQUIVALENTS UNDER THE LAWS OF ANY JURISDICTION), OR INFRINGEMENT OF ANY PATENT, COPYRIGHT OR OTHER INTELLECTUAL PROPERTY RIGHT.**

**UNLESS EXPRESSLY APPROVED IN WRITING BY TWO AUTHORIZED ST REPRESENTATIVES, ST PRODUCTS ARE NOT RECOMMENDED, AUTHORIZED OR WARRANTED FOR USE IN MILITARY, AIR CRAFT, SPACE, LIFE SAVING, OR LIFE SUSTAINING APPLICATIONS, NOR IN PRODUCTS OR SYSTEMS WHERE FAILURE OR MALFUNCTION MAY RESULT IN PERSONAL INJURY, DEATH, OR SEVERE PROPERTY OR ENVIRONMENTAL DAMAGE. ST PRODUCTS WHICH ARE NOT SPECIFIED AS "AUTOMOTIVE GRADE" MAY ONLY BE USED IN AUTOMOTIVE APPLICATIONS AT USER'S OWN RISK.**

Resale of ST products with provisions different from the statements and/or technical features set forth in this document shall immediately void any warranty granted by ST for the ST product or service described herein and shall not create or extend in any manner whatsoever, any liability of ST.

ST and the ST logo are trademarks or registered trademarks of ST in various countries.

Information in this document supersedes and replaces all information previously supplied.

The ST logo is a registered trademark of STMicroelectronics. All other names are the property of their respective owners.

© 2012 STMicroelectronics - All rights reserved

STMicroelectronics group of companies

Australia - Belgium - Brazil - Canada - China - Czech Republic - Finland - France - Germany - Hong Kong - India - Israel - Italy - Japan - Malaysia - Malta - Morocco - Philippines - Singapore - Spain - Sweden - Switzerland - United Kingdom - United States of America

[www.st.com](http://www.st.com)