

8-bit ultra-low-power touch sensing microcontroller with 16 Kbytes Flash, ProxSense™, timers, USART, SPI, I2C

Datasheet - production data

Features

- Operating conditions
 - Operating power supply: 1.65 V to 3.6 V
 - Temperature range: –40 °C to 85 °C
- Low power features
 - 4 low power modes: Wait, Active-halt with AWU (1 µA), Active-halt with ProxSense™ (10 µA with scan every 200 ms), Halt (0.4 µA)
 - Dynamic power consumption: 150 µA/MHz
 - Fast wakeup from Halt mode: 4.7 µs
 - Ultra-low leakage per I/O: 50 nA
- Advanced STM8 Core
 - Harvard architecture with 3-stage pipeline
 - Max freq. 16 MHz, 16 CISC MIPS peak
- Memories
 - Up to 16 Kbytes of Flash program including up to 2 Kbytes of data EEPROM
 - Error correction code (ECC)
 - Flexible write and read protection modes
 - In-application and in-circuit programming
 - Data EEPROM capability
 - 4 Kbytes of static RAM
- Clock management
 - Internal 16 MHz factory-trimmed RC
 - Internal 38 kHz low consumption RC driving both the IWDG and the AWU
- Reset and supply management
 - Ultra-low-power, ultra safe power-on reset/power-down reset
- Interrupt management
 - Nested interrupt controller with software priority control
 - Up to 22 external interrupt sources

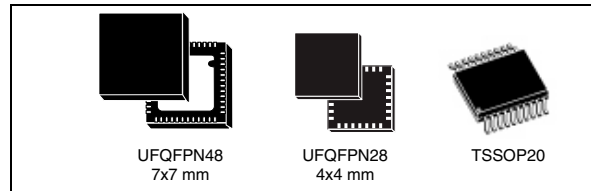

- I/Os
 - Up to 23 with 22 mappable on external interrupt vectors
 - I/Os with programmable input pull-ups, high sink/source capability
- ProxSense™ patented acquisition technology with up to 300 touch sensing channels (20 receiver/transmitter channels and 15 transmitter channels) supporting projected capacitive acquisition method suitable for proximity detection.
- Timers
 - Two 16-bit general purpose timers (TIM2 and TIM3) with up and down counter and two channels (used as IC, OC, PWM)
 - One 8-bit timer (TIM4) with 7-bit prescaler
 - Independent watchdog
 - Window watchdog
 - Auto-wakeup unit
 - Beeper timer with 1, 2 or 4 kHz frequencies
- Communication interfaces
 - SPI synchronous serial interface
 - Fast I²C Multimaster/slave 400 kHz
 - USART with fractional baud rate generator
- Development support
 - Hardware single wire interface module (SWIM)
 - In-circuit emulation (ICE)

Table 1. Device summary

Reference	Part number
STM8TL52x4	STM8TL52F4, STM8TL52G4
STM8TL53x4	STM8TL53C4, STM8TL53F4, STM8TL53G4

Contents

- 1 Introduction 8**
- 2 Description 9**
- 3 Product overview 11**
 - 3.1 Central processing unit STM8 12
 - 3.2 Development tools 13
 - 3.3 Single wire data interface (SWIM) and debug module 13
 - 3.4 Interrupt controller 13
 - 3.5 Memory 13
 - 3.6 Low power modes 14
 - 3.7 Voltage regulators 14
 - 3.7.1 Dual-mode voltage regulator 14
 - 3.7.2 ProxSense voltage regulator 14
 - 3.8 Clock control 14
 - 3.9 System configuration controller 15
 - 3.10 Independent watchdog 15
 - 3.11 Window watchdog 15
 - 3.12 Auto-wakeup counter 15
 - 3.13 General purpose and basic timers 15
 - 3.14 Beeper 16
 - 3.15 USART 16
 - 3.16 SPI 16
 - 3.17 I²C 16
 - 3.18 ProxSense 17
 - 3.19 TouchSensing dedicated library available upon request 17
- 4 Pin description 18**
- 5 Memory and register map 26**
- 6 Interrupt vector mapping 38**



7	Option bytes	40
8	Unique ID	42
9	Electrical parameters	43
9.1	Parameter conditions	43
9.1.1	Minimum and maximum values	43
9.1.2	Typical values	43
9.1.3	Typical curves	43
9.1.4	Loading capacitor	43
9.1.5	Pin input voltage	44
9.2	Absolute maximum ratings	44
9.3	Operating conditions	45
9.3.1	General operating conditions	45
9.3.2	Power supply	46
9.3.3	Power-up / power-down operating conditions	46
9.3.4	ProxSense Regulator Voltage	47
9.3.5	Supply current characteristics	47
9.3.6	Clock and timing characteristics	52
9.3.7	Memory characteristics	54
9.3.8	I/O port pin characteristics	56
9.3.9	Communication interfaces	64
9.3.10	EMC characteristics	68
9.4	Thermal characteristics	70
10	Package information	71
10.1	ECOPACK®	71
10.2	UFQFPN48 package information	71
10.3	UFQFPN28 package information	74
10.4	TSSOP20 package information	76
11	Part numbering	79
12	STM8 development tools	80
12.1	Software tools	80
12.1.1	STM8 toolset	80

12.1.2	STM-STUDIO	81
12.1.3	C and assembly toolchains	81
12.2	Programming tools	81
13	Revision history	82

List of tables

Table 1.	Device summary	1
Table 2.	Device features	10
Table 3.	Legends/abbreviations	22
Table 4.	STM8TL5xx4 pin description	22
Table 5.	Flash and RAM boundary addresses	27
Table 6.	I/O Port hardware register map	27
Table 7.	General hardware register map	28
Table 8.	CPU/SWIM/debug module/interrupt controller registers	36
Table 9.	Interrupt mapping	38
Table 10.	Option bytes	40
Table 11.	Option byte description	40
Table 12.	Unique ID registers (96 bits)	42
Table 13.	Voltage characteristics	44
Table 14.	Current characteristics	45
Table 15.	Thermal characteristics	45
Table 16.	General operating conditions	45
Table 17.	Operating conditions at power-up / power-down	46
Table 18.	ProxSense voltage regulator characteristics	47
Table 19.	Total current consumption in Run mode	47
Table 20.	Total current consumption in Wait mode	48
Table 21.	Total current consumption in Halt mode and Active-halt mode V _{DD} = 1.65 V to 3.6 V	50
Table 22.	Peripheral current consumption	51
Table 23.	ProxSense peripheral current consumption	51
Table 24.	HSI oscillator characteristics	52
Table 25.	HSI_PXS oscillator characteristics	53
Table 26.	LSI oscillator characteristics	53
Table 27.	RAM and hardware registers	54
Table 28.	Flash program memory	54
Table 29.	Program memory endurance and retention	55
Table 30.	Data memory endurance and retention	55
Table 31.	I/O static characteristics	56
Table 32.	Output driving current (high sink ports)	58
Table 33.	NRST pin characteristics	62
Table 34.	SPI characteristics	64
Table 35.	I ² C characteristics	67
Table 36.	EMS data	69
Table 37.	EMI data	69
Table 38.	ESD absolute maximum ratings	69
Table 39.	Electrical sensitivities	70
Table 40.	Thermal characteristics	70
Table 41.	UFQFPN48 - 48-lead, 7x7 mm, 0.5 mm pitch, ultra thin fine pitch quad flat package mechanical data	72
Table 42.	UFQFPN28 - 28-lead, 7x7 mm, 0.5 mm pitch, ultra thin fine pitch quad flat package mechanical data	74
Table 43.	TSSOP20 – 20-lead thin shrink small outline, 6.5 x 4.4 mm, 0.65 mm pitch, package mechanical data	76
Table 44.	Ordering information scheme	79

Table 45. Document revision history 82

List of figures

Figure 1.	STM8TL5xx4 block diagram	11
Figure 2.	STM8TL53 48-pin UFQFPN package pinout	18
Figure 3.	STM8TL53G4U6 28-pin UFQFPN package pinout	19
Figure 4.	STM8TL52G4U6 28-pin UFQFPN package pinout	20
Figure 5.	STM8TL53F4P6 TSSOP20 20-pin package pinout	21
Figure 6.	STM8TL52F4P6 TSSOP20 20-pin package pinout	21
Figure 7.	Memory map	26
Figure 8.	Pin loading conditions	43
Figure 9.	Pin input voltage	44
Figure 10.	Power supply scheme	46
Figure 11.	$I_{DD(RUN)}$ vs. V_{DD} , $f_{CPU} = 16$ MHz	48
Figure 12.	$I_{DD(Wait)}$ vs. V_{DD} , $f_{CPU} = 16$ MHz	49
Figure 13.	Typ. $I_{DD(Halt)}$ vs. V_{DD} , $f_{CPU} = 2$ MHz and 16 MHz	50
Figure 14.	Typical HSI frequency vs. V_{DD}	52
Figure 15.	Typical HSI accuracy vs. temperature, $V_{DD} = 3$ V	53
Figure 16.	Typical LSI frequency vs. V_{DD}	54
Figure 17.	Typical pull-up resistance R_{PU} vs. V_{DD} with $V_{IN}=V_{SS}$	56
Figure 18.	Typical V_{IL} and V_{IH} vs V_{DD}	57
Figure 19.	Typ. V_{OL} at $V_{DD} = 1.8$ V (standard ports)	58
Figure 20.	Typ. V_{OL} at $V_{DD} = 3.0$ V (standard ports)	59
Figure 21.	Typ. $V_{DD} - V_{OH}$ at $V_{DD} = 1.8$ V (standard ports)	59
Figure 22.	Typ. $V_{DD} - V_{OH}$ at $V_{DD} = 3.0$ V (standard ports)	60
Figure 23.	Typ. $V_{DD} - V_{OH}$ at $V_{DD} = 1.8$ V (ProxSense_TX ports)	60
Figure 24.	Typ. $V_{DD} - V_{OH}$ at $V_{DD} = 1.8$ V (ProxSense_RX ports)	61
Figure 25.	Typical NRST pull-up resistance R_{PU} vs. V_{DD}	62
Figure 26.	Recommended NRST pin configuration	63
Figure 27.	SPI timing diagram - slave mode and $CPHA = 0$	65
Figure 28.	SPI timing diagram - slave mode and $CPHA = 1^{(1)}$	65
Figure 29.	SPI timing diagram - master mode ⁽¹⁾	66
Figure 30.	Typical application with I ² C bus and timing diagram 1)	68
Figure 31.	UFQFPN48 - 48-lead, 7x7 mm, 0.5 mm pitch, ultra thin fine pitch quad flat package outline	71
Figure 32.	UFQFPN48 - 48-lead, 7x7 mm, 0.5 mm pitch, ultra thin fine pitch quad flat package recommended footprint	72
Figure 33.	UFQFPN48 marking example (package top view)	73
Figure 34.	UFQFPN28 - 28-lead, 7x7 mm, 0.5 mm pitch, ultra thin fine pitch quad flat package outline	74
Figure 35.	UFQFPN28 - 28-lead, 7x7 mm, 0.5 mm pitch, ultra thin fine pitch quad flat package recommended footprint	75
Figure 36.	UFQFPN28 marking example (package top view)	75
Figure 37.	TSSOP20 – 20-lead thin shrink small outline, 6.5 x 4.4 mm, 0.65 mm pitch, package outline	76
Figure 38.	TSSOP20 – 20-lead thin shrink small outline, 6.5 x 4.4 mm, 0.65 mm pitch, package footprint	77
Figure 39.	TSSOP20 marking example (package top view)	78

1 Introduction

This datasheet provides the STM8TL52G4, STM8TL52F4, STM8TL53C4, STM8TL53G4 and STM8TL53F4 pinouts, ordering information, mechanical and electrical device characteristics.

For complete information on the microcontroller memory, registers and peripherals, please refer to the STM8TL5xxx reference manual (RM0312) and to the STM8TL5xxx Flash programming manual (PM0212) for Flash memory related information. For information on the debug module and SWIM (single wire interface module), refer to the STM8 SWIM communication protocol and debug module user manual (UM0470). For information on the STM8 core, refer to the STM8 CPU programming manual (PM0044).

All devices of the STM8TL5xxx product line provide the following benefits:

- Advanced capacitive sensing
 - Patented ProxSense™ acquisition peripheral, providing high-end acquisition, filtering and environment adaptation
 - Outstanding signal-to-noise ratio for touch and proximity sensing
 - Up to 300 projected capacitive channels
- Reduced system cost
 - Up to 16 Kbytes of low-density embedded Flash program memory including up to 2 Kbytes of data EEPROM
 - High system integration level with internal clock oscillators and watchdogs
 - Smaller battery and cheaper power supplies
- Low power consumption and advanced features
 - Up to 16 MIPS at 16 MHz CPU clock frequency
 - Less than 150 µA/MHz, 0.8 µA in Active-halt mode with AWU, and 0.3 µA in Halt mode
 - Clock gated system and optimized power management
- Short development cycles
 - Application scalability across a common family product architecture with compatible pinout, memory map and modular peripherals
 - Full documentation and a wide choice of development tools
- Product longevity
 - Advanced core and peripherals made in a state-of-the-art technology
 - Product family operating from 1.65 V to 3.6 V supply

Note: ProxSense™ is a trademark of Azoteq (Pty) Ltd.

2 Description

The STM8TL5xx4 devices feature the enhanced STM8 CPU core providing increased processing power (up to 16 MIPS at 16 MHz) while maintaining the advantages of a CISC architecture with improved code density, a 24-bit linear addressing space and an optimized architecture for low power operations. It uses a ProxSense charge transfer capacitive acquisition method that is capable of near range proximity detection.

The family includes an integrated debug module with a hardware interface (SWIM) which allows non-intrusive in-application debugging and ultrafast Flash programming. All STM8TL5xx4 microcontrollers feature low power low-voltage single-supply program Flash memory.

The STM8TL5xx4 are based on a generic set of state-of-the-art peripherals. The modular design of the peripheral set allows the same peripherals to be found in different ST microcontroller families including 32-bit families. This makes any transition to a different family very easy, and simplified even more by the use of a common set of development tools.

Table 2. Device features

Features	STM8TL52F4	STM8TL53F4	STM8TL52G4	STM8TL53G4	STM8TL53C4
Flash (Kbytes)	16				
Data EEPROM (Kbytes)	2				
RAM (Kbytes)	4				
Timers	Basic	1 (8-bit)			
	General purpose	2 (16-bit)			
Communication Interfaces	SPI	1			
	I2C	1			
	USART	1			
GPIOs	12		17		23
ProxSense	Up to 12 touch sensing channels (5 receiver/transmitter channels and 2 transmitter channels)	Up to 30 touch sensing channels (5 receiver/transmitter channels and 6 transmitter channels)	Up to 25 touch sensing channels (8 receiver/transmitter channels and 2 transmitter channels)	Up to 72 touch sensing channels (8 receiver/transmitter channels and 9 transmitter channels)	Up to 300 touch sensing channels (20 receiver/transmitter channels and 15 transmitter channels)
Others	Window watchdog, independent watchdog, two 16-MHz and one 38-kHz internal RC, auto-wakeup counter, beeper				
CPU frequency	16 MHz				
Operating voltage	1.65 to 3.6 V				
Operating temperature	-40 to +85 °C				
Packages	TSSOP20		UFQFPN28		UFQFPN48

3 Product overview

Figure 1. STM8TL5xx4 block diagram

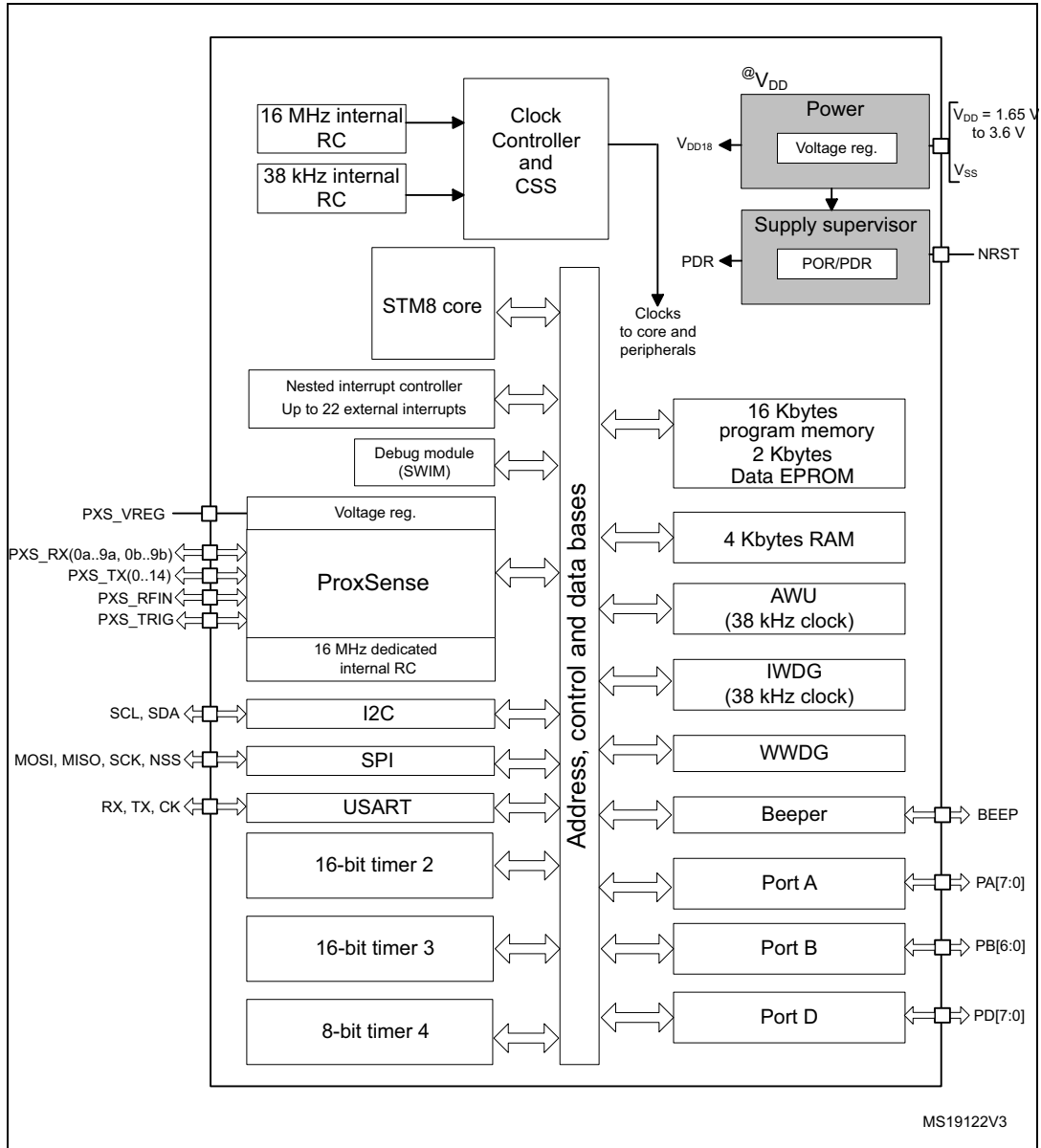

Legend:

- AWU: Auto-wakeup unit
- Int. RC: internal RC oscillator
- I²C: Inter-integrated circuit multimaster interface
- POR/PDR: Power on reset / power down reset
- SPI: Serial peripheral interface
- SWIM: Single wire interface module
- USART: Universal synchronous / asynchronous receiver / transmitter
- IWDG: Independent watchdog
- WWDG: Window watchdog
- ProxSense™: capacitive sensing peripheral

3.1 Central processing unit STM8

The 8-bit STM8 core is designed for code efficiency and performance with an Harvard architecture and a 3-stage pipeline.

It contains 6 internal registers which are directly addressable in each execution context, 20 addressing modes including indexed indirect and relative addressing, and 80 instructions.

Architecture and registers

- Harvard architecture
- 3-stage pipeline
- 32-bit wide program memory bus - single cycle fetching most instructions
- X and Y 16-bit index registers - enabling indexed addressing modes with or without offset and read-modify - write type data manipulations
- 8-bit accumulator
- 24-bit program counter - 16 Mbyte linear memory space
- 16-bit stack pointer - access to a 64 Kbytes level stack
- 8-bit condition code register - 7 condition flags for the result of the last instruction

Addressing

- 20 addressing modes
- Indexed indirect addressing mode for lookup tables located anywhere in the address space
- Stack pointer relative addressing mode for local variables and parameter passing

Instruction set

- 80 instructions with 2-byte average instruction size
- Standard data movement and logic/arithmetic functions
- 8-bit by 8-bit multiplication
- 16-bit by 8-bit and 16-bit by 16-bit division
- Bit manipulation
- Data transfer between stack and accumulator (push/pop) with direct stack access
- Data transfer using the X and Y registers or direct memory-to-memory transfers

3.2 Development tools

Development tools for the STM8 microcontrollers include:

- The ST-Link very low-cost professional tool to debug and program
- The STVD high-level language debugger including C compiler, assembler and integrated development environment
- The STVP Flash programming software
- The STM-STUDIO real-time and non-intrusive graphical interface used to probe application variables and data

The STM8 also comes with starter kits, evaluation boards and low-cost in-circuit debugging/programming tools.

3.3 Single wire data interface (SWIM) and debug module

The debug module with its single wire data interface (SWIM) permits non-intrusive real-time in-circuit debugging and fast memory programming.

The Single wire interface is used for direct access to the debugging module and memory programming. The interface can be activated in all device operation modes.

The non-intrusive debugging module features a performance close to a full-featured emulator. Beside memory and peripherals, also CPU operation can be monitored in real-time by means of shadow registers.

3.4 Interrupt controller

The STM8TL5xx4 devices feature a nested vectored interrupt controller:

- Nested interrupts with 3 software priority levels
- 22 interrupt vectors with hardware priority
- Up to 22 external interrupt sources on 10 vectors
- TRAP and RESET interrupts

3.5 Memory

The STM8TL5xx4 devices have the following main features:

- 4 Kbytes of RAM
- The EEPROM is divided into two memory arrays (see the STM8TL5xxx reference manual (RM0312) for details on the memory mapping):
 - 16 Kbytes of low-density embedded Flash program including up to 2 Kbytes of data EEPROM. Data EEPROM and Flash program areas can be write protected independently by using the memory access security mechanism (MASS).
 - 64 option bytes (one block) of which 5 bytes are already used for the device.
 - Error correction code is implemented on the EEPROM.

3.6 Low power modes

To minimize power consumption, the product features three MCU low power modes:

- Wait mode: CPU clock stopped, selected peripherals at full clock speed.
- Active-halt mode:
 - When wakeup time is programmed in the AWU unit, the CPU and peripheral clocks are stopped. The RAM content is preserved.
 - When a ProxSense acquisition is ongoing, the wakeup is on ProxSense interrupts; the CPU and the other peripheral clocks are stopped.
- Halt mode: CPU and peripheral clocks are stopped, the device remains powered on. Wakeup is triggered by an external interrupt.

The ProxSense peripheral can return to low power mode between each conversion. The ProxSense acquisition can be operated in Run, Wait and Active-halt modes.

3.7 Voltage regulators

The STM8TL5xx4 devices embed an internal voltage regulator for generating the 1.8 V power supply for the core and peripherals and a second internal voltage regulator providing a stable power supply (around 1.45V) for the ProxSense peripheral.

3.7.1 Dual-mode voltage regulator

This regulator has two different modes: main voltage regulator mode (MVR) and low power voltage regulator mode (LPVR). When in Active-halt mode, the regulator remains in MVR if ProxSense is active. When entering Halt or Active-halt modes, the system automatically switches from the MVR to the LPVR in order to reduce current consumption unless ProxSense is enabled.

3.7.2 ProxSense voltage regulator

This regulator provides a very stable voltage to power the ProxSense peripheral including ProxSense pins in order to be independent of any power supply variations. This regulator is switched on while the ProxSense peripheral is enabled (bit PXSEN = 1) and bit LOW_POWER is set to '0' in register PXS_CR1. Otherwise, when LOW_POWER is set to '1', this regulator is only enabled during conversions (while CIPF = 1 and SYNC PF = 0).

3.8 Clock control

The STM8TL5xx4 embeds a robust clock controller. It is used to distribute the system clock (SYSCLK) to the core and the peripherals and to manage clock gating for low power modes. This system clock is a 16-MHz High Speed Internal RC oscillator (HSI RC), followed by a programmable prescaler.

In addition, a 38 kHz low speed internal RC oscillator is used by the Independent watchdog (IWDG) and Auto-wakeup unit (AWU).

3.9 System configuration controller

The system configuration controller provides the capability to remap some alternate functions on different I/O ports. TIM3 channels can be remapped.

3.10 Independent watchdog

The independent watchdog (IWDG) peripheral can be used to resolve processor malfunctions due to hardware or software failures.

It is clocked by the 38 kHz LSI internal RC clock source, and thus stays active even in case of a CPU clock failure.

3.11 Window watchdog

The window watchdog (WWDG) is based on a 7-bit downcounter that can be set as free-running. It can be used as a watchdog to reset the device when a problem occurs. It is clocked from the main clock. It has an early warning interrupt capability and the counter can be frozen in debug mode.

3.12 Auto-wakeup counter

The auto-wakeup (AWU) counter is used to wakeup the device from Active-halt mode.

3.13 General purpose and basic timers

STM8TL5xx4 devices contain two 16-bit general purpose timers (TIM2 and TIM3) and one 8-bit basic timer (TIM4).

16-bit general purpose timers

The 16-bit timers consist of 16-bit up/down auto-reload counters driven by a programmable prescaler. They perform a wide range of functions, including:

- Timebase generation
- Measuring the pulse lengths of input signals (input capture)
- Generating output waveforms (output compare, PWM and One pulse mode)
- Interrupt capability on various events (capture, compare, overflow, break, trigger)
- Synchronization with other timers or external signals (external clock, reset, trigger and enable)

8-bit basic timer

The 8-bit timer consists of an 8-bit up auto-reload counter driven by a programmable prescaler. It can be used for timebase generation with interrupt generation on timer overflow.

3.14 Beeper

STM8TL5xx4 devices include a beeper function used to generate a beep signal in the range of 1, 2 or 4 kHz when the LSI clock is operating at a frequency of 38 kHz.

3.15 USART

The USART interface (USART) allows full duplex, asynchronous communications with external devices requiring an industry standard NRZ asynchronous serial data format. It offers a very wide range of baud rates.

- 1 Mbit/s full duplex SCI
- SPI emulation
- High precision baud rate generator
- Single wire half duplex mode

3.16 SPI

The serial peripheral interface (SPI) provides half/ full duplex synchronous serial communication with external devices.

- Maximum speed: 8 Mbit/s ($f_{\text{SYSCLK}}/2$) both for master and slave
- Full duplex synchronous transfers
- Simplex synchronous transfers on 2 lines with a possible bidirectional data line
- Master or slave operation - selectable by hardware or software
- Hardware CRC calculation
- Slave/master selection input pin

3.17 I²C

The I²C bus interface (I²C) provides multi-master capability, and controls all I²C bus-specific sequencing, protocol, arbitration and timing.

- Master, slave and multi-master capability
- Dual addressing mode capability
- Standard mode up to 100 kHz and fast speed modes up to 400 kHz
- 7-bit and 10-bit addressing modes
- Hardware CRC calculation

3.18 ProxSense

The ProxSense peripheral uses a charge-transfer method to detect capacitance changes.

- Up to 300 capacitive sensing channels composed of 15 transmitters and 20 receivers with up to 10 Rx channels acquired in parallel
- Fast acquisition with a typical scan time of 250 μ s for 10 Rx channels
- Configurable internal sampling capacitor (C_S)
- Electrode Parasitic Capacitance Compensation (EPCC) to ensure the best sensitivity in all user environments
- RF noise detection, allowing to reject corrupted samples
- External trigger to de-synchronize the acquisition from known noise
- Can be configured to return to low power mode between each conversion
- Acquisition possible in Run, Wait and Active-halt modes

3.19 TouchSensing dedicated library available upon request

- Complete C source code library with firmware examples (MISRA compliant)
- Multifunction capability to combine capacitive sensing functions with traditional MCU features
- Compatible with proximity, touchkey, linear and rotary touch sensor implementation
- Configuration of all ProxSense parameters
- Extra filtering and calibration functions
- TouchSensing user interface through firmware API for status reporting and application configuration
- Compliance with Cosmic, IAR and Raisonance C compilers

4 Pin description

Figure 2. STM8TL53 48-pin UFQFPN package pinout

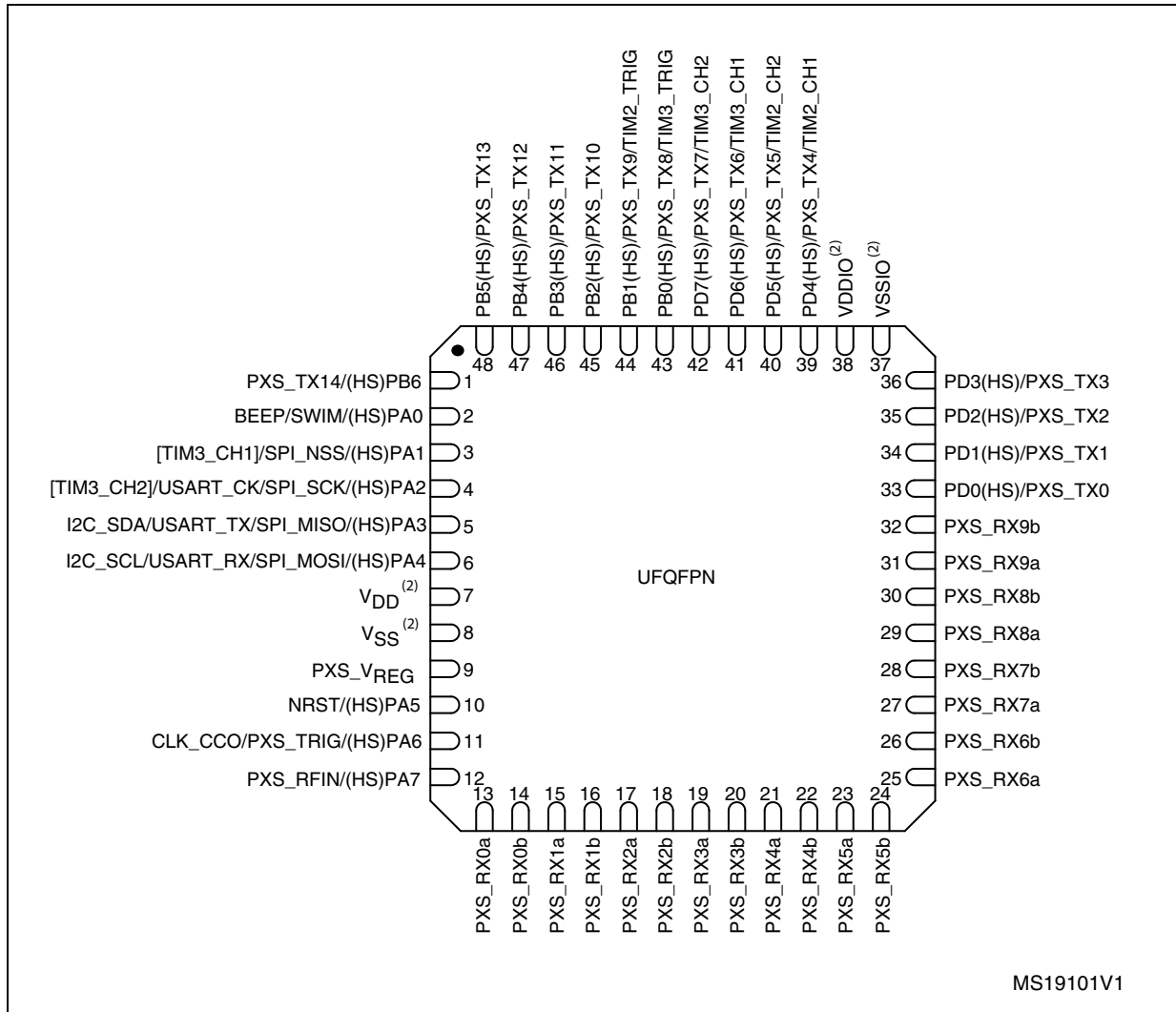

1. HS corresponds to 20 mA high sink/source capability.
2. Power supply pins must be correctly decoupled with capacitors near the pins. Please refer to the power supply circuitry details in [Section 9.3.2: Power supply on page 46](#) and the STM8TL5xxx reference manual (RM0312), Section 6: Power supply.

Figure 3. STM8TL53G4U6 28-pin UFQFPN package pinout

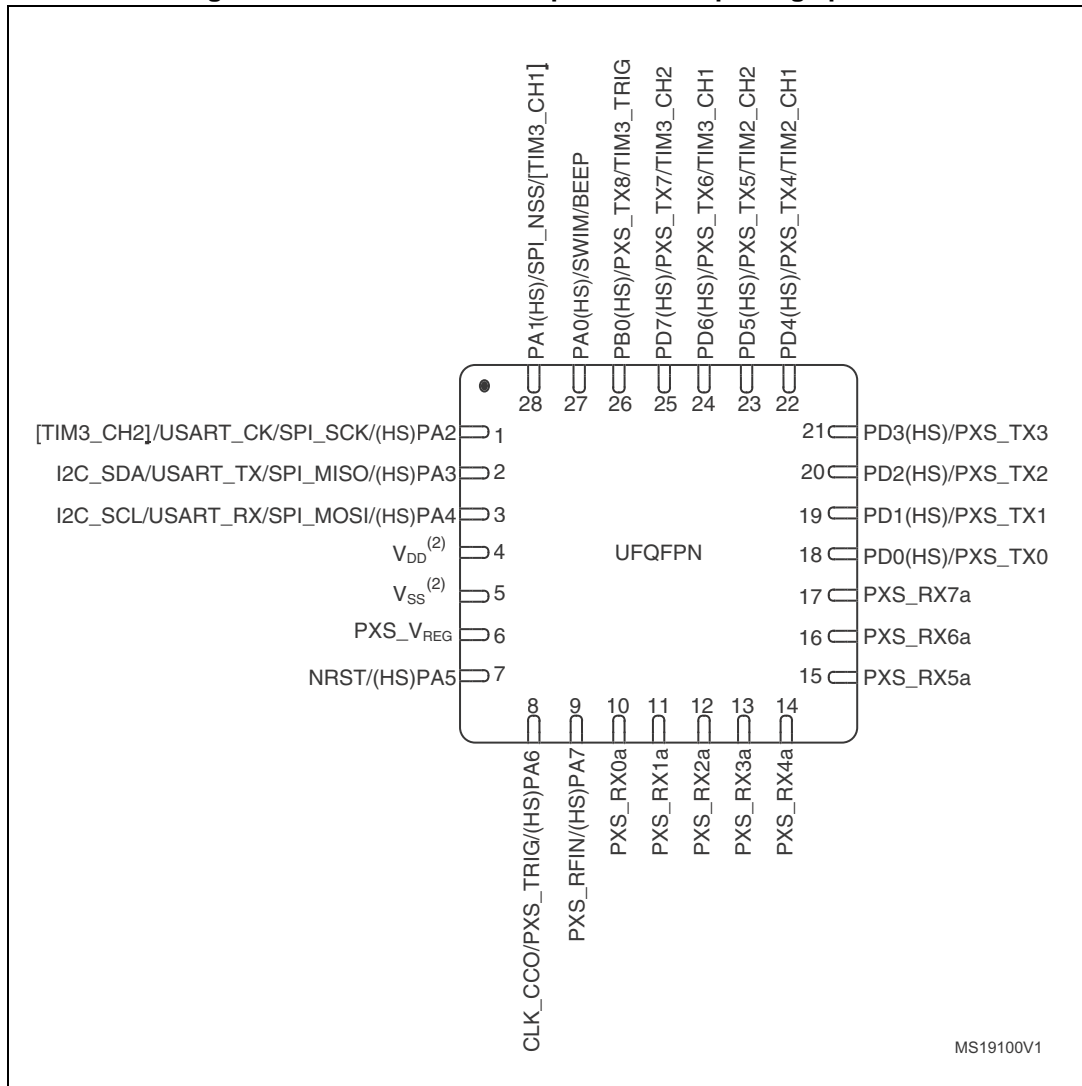

1. HS corresponds to 20 mA high sink/source capability.
2. Power supply pins must be correctly decoupled with capacitors near the pins. Please refer to the power supply circuitry details in [Section 9.3.2: Power supply on page 46](#) and the STM8TL5xxx reference manual (RM0312), Section 6: Power supply.

Figure 4. STM8TL52G4U6 28-pin UFQFPN package pinout

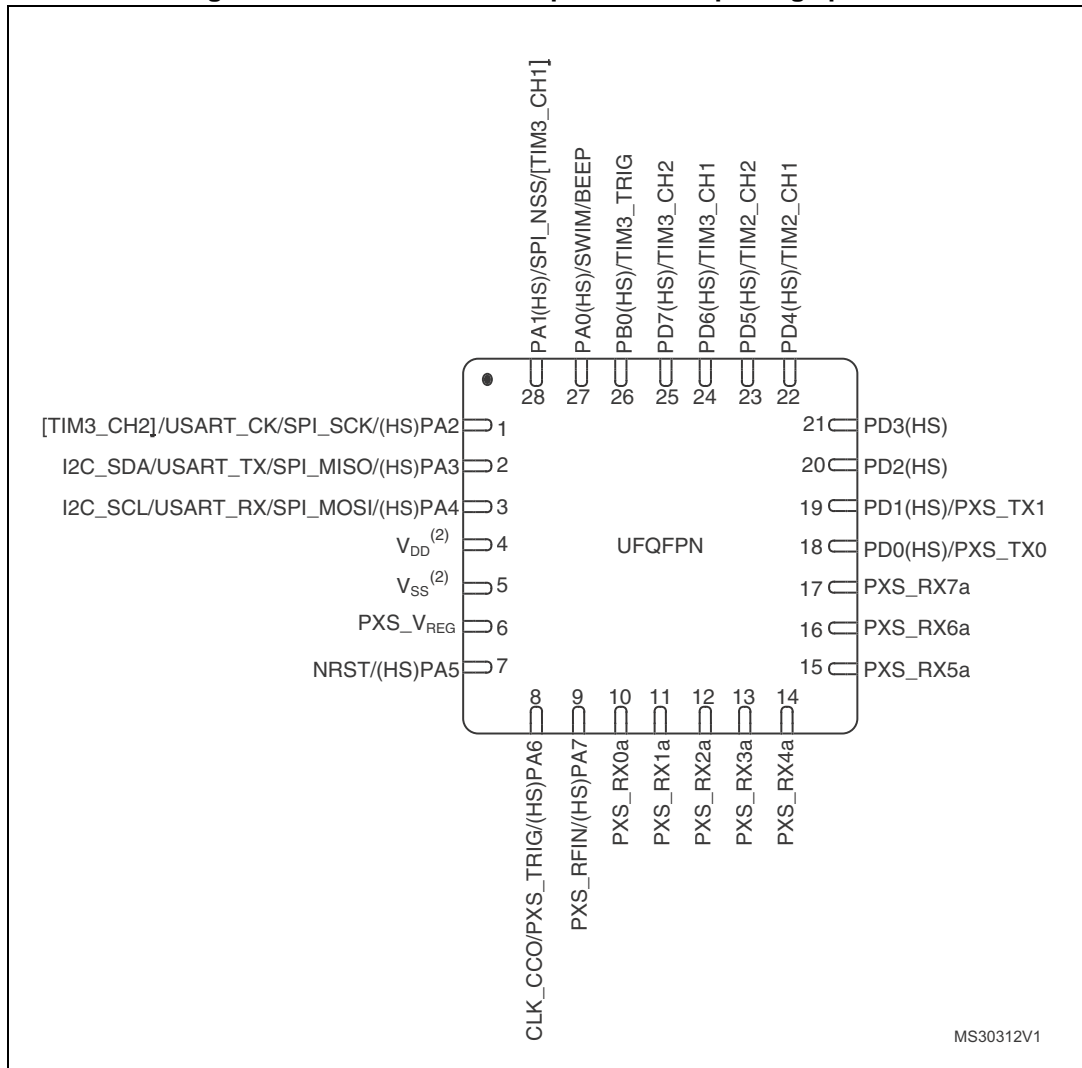

1. HS corresponds to 20 mA high sink/source capability.
2. Power supply pins must be correctly decoupled with capacitors near the pins. Please refer to the power supply circuitry details in [Section 9.3.2: Power supply on page 46](#) and the STM8TL5xxx reference manual (RM0312) Section 6: Power supply.

Figure 5. STM8TL53F4P6 TSSOP20 20-pin package pinout

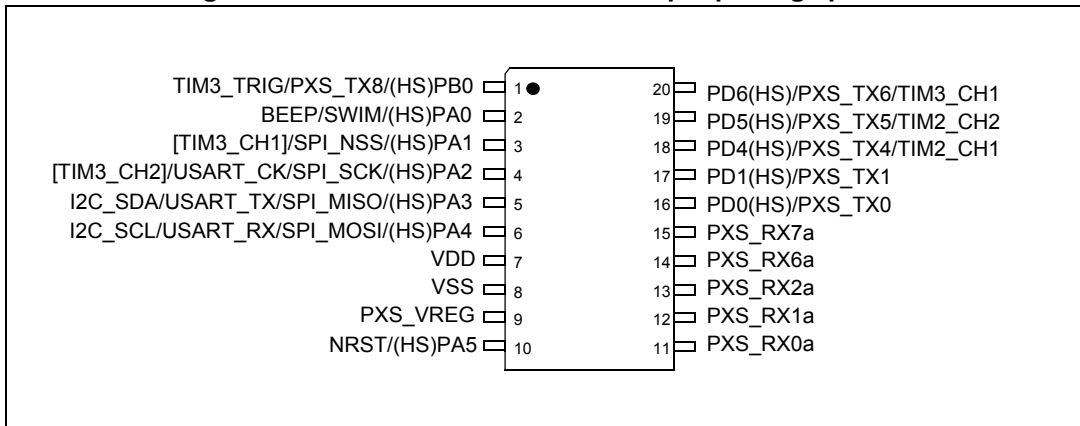

1. HS corresponds to 20 mA high sink/source capability.
2. Power supply pins must be correctly decoupled with capacitors near the pins. Please refer to the power supply circuitry details in [Section 9.3.2: Power supply on page 46](#) and the STM8TL5xxx reference manual (RM0312) Section 6: Power supply.

Figure 6. STM8TL52F4P6 TSSOP20 20-pin package pinout

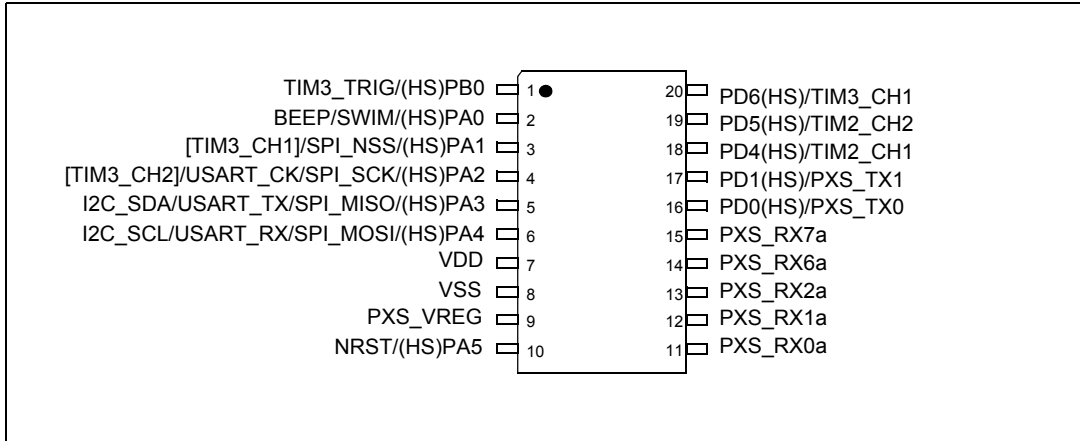

1. HS corresponds to 20 mA high sink/source capability.
2. Power supply pins must be correctly decoupled with capacitors near the pins. Please refer to the power supply circuitry details in [Section 9.3.2: Power supply on page 46](#) and the STM8TL5xxx reference manual (RM0312) Section 6: Power supply.

Table 3. Legends/abbreviations

Type	I = input, O = output, S = power supply	
Level	Input	FT = 5 V tolerant, TC = 3 V capable
	Output	HS = high sink/source (20 mA)
Port and control configuration	Input	float = floating, wpu = weak pull-up
	Output	T = true open drain, OD = open drain, PP = push-pull
Reset state	Bold X (pin state after reset release). Unless otherwise specified, the pin state is the same during the reset phase (i.e. "under reset") and after internal reset release (i.e. at reset state).	

Table 4. STM8TL5xx4 pin description

Pin no.			Pin name	Type	Input				Output			Main function (after reset)	Alternate function	
UFQFPN48	UFQFPN28	TSSOP20			Level	floating	wpu	Ext. interrupt	High sink/source	OD	PP		Default	Remap
1			PB6/ PXS_TX14	I/O	TC	X	X	X	HS	X	X	Port B6	ProxSense transmit 14	
2	27	2	PA0 ⁽¹⁾ /SWIM/ BEEP	I/O	TC	X	X	X	HS	X	X	SWIM	Port A0 ⁽¹⁾	
													SWIM input and output	
													Beep output	
3	28	3	PA1/SPI_NSS/ [TIM3_CH1]	I/O	FT	X	X	X	HS	X	X	Port A1	SPI master/ slave select	Timer 3 - channel 1
4	1	4	PA2/SPI_SCK/ USART_CK/ [TIM3_CH2] ⁽²⁾	I/O	FT	X	X	X	HS	X	X	Port A2	SPI clock	Timer 3 - channel 2
													USART synchronous clock	
5	2	5	PA3/SPI_MISO/ USART_TX/ I2C_SDA ⁽²⁾	I/O	FT	X	X	X	HS	X	X	Port A3	SPI master in/ slave out	
													USART transmit	
													I ² C data	
6	3	6	PA4/SPI_MOSI/ USART_RX/ I2C_SCL	I/O	FT	X	X	X	HS	X	X	Port A4	SPI master out/ slave in	
													USART receive	
													I ² C clock	
7	4	7	VDD	S								Digital power supply		

Table 4. STM8TL5xx4 pin description (continued)

Pin no.			Pin name	Type	Input				Output			Main function (after reset)	Alternate function	
UFQFPN48	UFQFPN28	TSSOP20			Level	floating	wpu	Ext. interrupt	High sink/source	OD	PP		Default	Remap
8	5	8	VSS	S							Digital ground			
9	6	9	PXS_VREG	S								ProxSense voltage regulator External decoupling capacitor		
10	7	10	PA5/NRST ⁽³⁾	I/O	TC			HS	X	X	Reset	Port A5 (output only)		
11	8		PA6/ PXS_TRIG/ CLK_CCO	I/O	FT	X	X	X	HS	X	X	Port A6	ProxSense external trigger input CLK clock output	
12	9		PA7/PXS_RFIN	I/O	TC	X	X	X	HS	X	X	Port A7	ProxSense antenna input	
13	10	11	PXS_RX0a									PXS_RX0a	ProxSense receiver 0a	
14			PXS_RX0b									PXS_RX0b	ProxSense receiver 0b	
15	11	12	PXS_RX1a									PXS_RX1a	ProxSense receiver 1a	
16			PXS_RX1b									PXS_RX1b	ProxSense receiver 1b	
17	12	13	PXS_RX2a									PXS_RX2a	ProxSense receiver 2a	
18			PXS_RX2b									PXS_RX	ProxSense receiver 2b	
19	13		PXS_RX3a									PXS_RX3a	ProxSense receiver 3a	
20			PXS_RX3b									PXS_RX3b	ProxSense receiver 3b	
21	14		PXS_RX4a									PXS_RX4a	ProxSense receiver 4a	
22			PXS_RX4b									PXS_RX4b	ProxSense receiver 4b	



Table 4. STM8TL5xx4 pin description (continued)

Pin no.			Pin name	Type	Input				Output			Main function (after reset)	Alternate function	
UFQFPN48	UFQFPN28	TSSOP20			Level	floating	wpu	Ext. interrupt	High sink/source	OD	PP		Default	Remap
23	15		PXS_RX5a								PXS_RX5a	ProxSense receiver 5a		
24			PXS_RX5b								PXS_RX5b	ProxSense receiver 5b		
25	16	14	PXS_RX6a								PXS_RX6a	ProxSense receiver 6a		
26			PXS_RX6b								PXS_RX6b	ProxSense receiver 6b		
27	17	15	PXS_RX7a								PXS_RX7a	ProxSense receiver 7a		
28			PXS_RX7b								PXS_RX7b	ProxSense receiver 7b		
29			PXS_RX8a								PXS_RX8a	ProxSense receiver 8a		
30			PXS_RX8b								PXS_RX8b	ProxSense receiver 8b		
31			PXS_RX9a								PXS_RX9a	ProxSense receiver 9a		
32			PXS_RX9b								PXS_RX9b	ProxSense receiver 9b		
33	18	16	PD0/PXS_TX0	I/O	TC	X	X	X	HS	X	X	Port D0	ProxSense transmitter 0	
34	19	17	PD1/PXS_TX1	I/O	TC	X	X	X	HS	X	X	Port D1	ProxSense transmitter 1	
35	20		PD2/PXS_TX2 ⁽⁴⁾	I/O	TC	X	X	X	HS	X	X	Port D2	ProxSense transmitter 2 ⁽⁴⁾	
36	21		PD3/PXS_TX3 ⁽⁴⁾	I/O	TC	X	X	X	HS	X	X	Port D3	ProxSense transmitter 3 ⁽⁴⁾	
37			VSSIO	S								IOs ground		
38			VDDIO	S								IOs power supply		
39	22	18	PD4/PXS_TX4 ⁽⁴⁾ / TIM2_CH1	I/O	TC	X	X	X	HS	X	X	Port D4	ProxSense transmitter 4 ⁽⁴⁾ Timer 2 - channel 1	

Table 4. STM8TL5xx4 pin description (continued)

Pin no.			Pin name	Type	Input				Output			Main function (after reset)	Alternate function	
UFQFPN48	UFQFPN28	TSSOP20			Level	floating	wpu	Ext. interrupt	High sink/source	OD	PP		Default	Remap
40	23	19	PD5/PXS_TX5 ⁽⁴⁾ / TIM2_CH2	I/O	TC	X	X	X	HS	X	X	Port D5	ProxSense transmitter 5 ⁽⁴⁾ Timer 2 - channel 2	
41	24	20	PD6/PXS_TX6 ⁽⁴⁾ / TIM3_CH1	I/O	TC	X	X	X	HS	X	X	Port D6	ProxSense transmitter 6 ⁽⁴⁾ Timer 3 - channel1	
42	25		PD7/PXS_TX7 ⁽⁴⁾ / TIM3_CH2	I/O	TC	X	X	X	HS	X	X	Port D7	ProxSense transmitter 7 ⁽⁴⁾ Timer 3 - channel 2	
43	26	1	PB0/PXS_TX8 ⁽⁴⁾ / TIM3_ETR	I/O	TC	X	X	X	HS	X	X	Port B0	ProxSense transmitter 8 ⁽⁴⁾ Timer 3 - external trigger	
44			PB1 ⁽²⁾ /PXS_TX9 / TIM2_ETR	I/O	TC	X	X	X	HS	X	X	Port B1	ProxSense transmitter 9 Timer 2 - external trigger	
45			PB2/PXS_TX10	I/O	TC	X	X	X	HS	X	X	Port B2	ProxSense transmitter 10	
46			PB3/PXS_TX11	I/O	TC	X	X	X	HS	X	X	Port B3	ProxSense transmitter 11	
47			PB4/PXS_TX12	I/O	TC	X	X	X	HS	X	X	Port B4	ProxSense transmitter 12	
48			PB5/PXS_TX13	I/O	TC	X	X	X	HS	X	X	Port B5	ProxSense transmitter 13	

1. The PA0/SWIM pin is in input pull-up during the reset phase and after reset release.
2. A pull-up is applied to PA2, PA3 and PB1 during the reset phase. These three pins are input floating after reset release.
3. At power-up, the PA5/NRST pin is a reset input pin with pull-up. To be used as a general purpose pin (PA5), it can be configured only as output open-drain or push-pull, not as a general purpose input. Refer to Section Configuring NRST/PA5 pin as general purpose output in the STM8TL5xxx reference manual (RM0312).
4. Not available for STM8TL52xx.

5 Memory and register map

Figure 7. Memory map

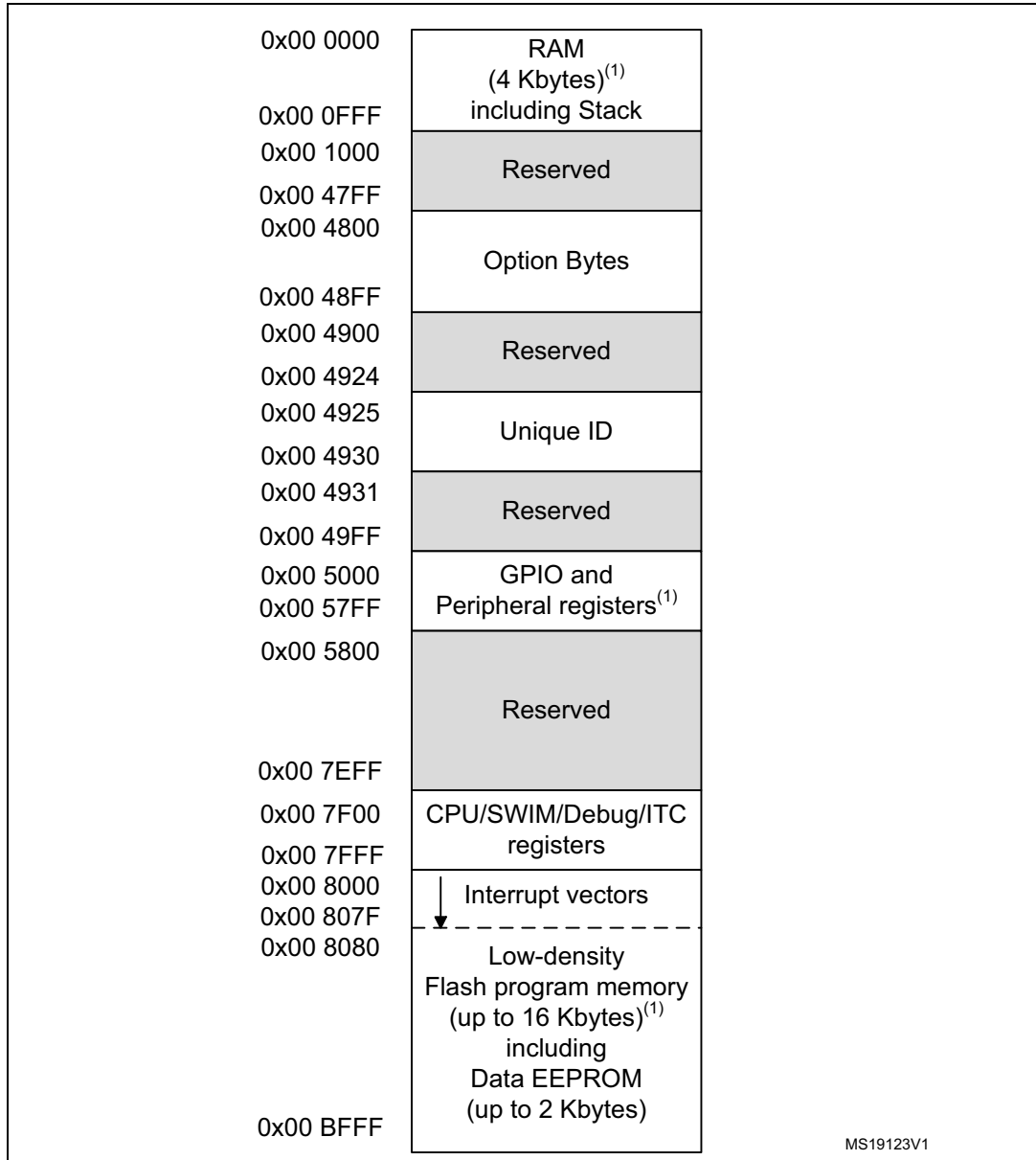

1. Refer to [Table 7](#) for an overview of hardware register mapping, to [Table 6](#) for details on I/O port hardware registers, and to [Table 8](#) for information on CPU/SWIM/debug module controller registers.

Table 5. Flash and RAM boundary addresses

Memory area	Size	Start address	End address
RAM	4 Kbytes	0x00 0000	0x00 0FFF
Flash program memory	16 Kbytes	0x00 8000	0x00 BFFF

Table 6. I/O Port hardware register map

Address	Block	Register label	Register name	Reset status
0x00 5000	Port A	PA_ODR	Port A data output latch register	0x00
0x00 5001		PA_IDR	Port A input pin value register	0xXX
0x00 5002		PA_DDR	Port A data direction register	0x00
0x00 5003		PA_CR1	Port A control register 1	0x00
0x00 5004		PA_CR2	Port A control register 2	0x00
0x00 5005	Port B	PB_ODR	Port B data output latch register	0x00
0x00 5006		PB_IDR	Port B input pin value register	0xXX
0x00 5007		PB_DDR	Port B data direction register	0x00
0x00 5008		PB_CR1	Port B control register 1	0x00
0x00 5009		PB_CR2	Port B control register 2	0x00
0x00 500A to 0x00 500E	Reserved area (5 bytes)			
0x00 500F	Port D	PD_ODR	Port D data output latch register	0x00
0x00 5010		PD_IDR	Port D input pin value register	0xXX
0x00 5011		PD_DDR	Port D data direction register	0x00
0x00 5012		PD_CR1	Port D control register 1	0x00
0x00 5013		PD_CR2	Port D control register 2	0x00

Table 7. General hardware register map

Address	Block	Register label	Register name	Reset status
0x00 5050	Flash	FLASH_CR1	Flash control register 1	0x00
0x00 5051		FLASH_CR2	Flash control register 2	0x00
0x00 5052		FLASH_PUKR	Flash Program memory unprotection register	0x00
0x00 5053		FLASH_DUKR	Data EEPROM unprotection register	0x00
0x00 5054		FLASH_IAPSR	Flash in-application programming status register	0xX0
0x00 5055 to 0x00 509D	Reserved area (73 bytes)			
0x00 509E	SYSCFG	SYSCFG_RMPCR1	Remapping control register 1	0x00
0x00 509F	Reserved area (1 byte)			
0x00 50A0	ITC-EXTI	EXTI_CR1	External interrupt control register 1	0x00
0x00 50A1		EXTI_CR2	External interrupt control register 2	0x00
0x00 50A2		EXTI_CR3	External interrupt control register 3	0x00
0x00 50A3		EXTI_SR1	External interrupt status register 1	0x00
0x00 50A4		EXTI_SR2	External interrupt status register 2	0x00
0x00 50A5		EXTI_CONF	External interrupt port select register	0x00
0x00 50A6	WFE	WFE_CR1	WFE control register 1	0x00
0x00 50A7		WFE_CR2	WFE control register 2	0x00
0x00 50A8 to 0x00 50AF	Reserved area (8 bytes)			
0x00 50B0	RST	RST_CR	Reset control register	0x00
0x00 50B1		RST_SR	Reset status register	0x01 ⁽¹⁾
0x00 50B2 to 0x00 50BF	Reserved area (14 bytes)			
0x00 50C0	CLK	CLK_CKDIVR	Clock divider register	0x00
0x00 50C1 to 0x00 50C2		Reserved area (2 bytes)		
0x00 50C3		CLK_PCKENR1	Peripheral clock gating register 1	0x00
0x00 50C4		CLK_PCKENR2	Peripheral clock gating register 2	0x01
0x00 50C5		CLK_CCOR	Configurable clock control register	0x10
0x00 50C6 to 0x00 50D2	Reserved area (12 bytes)			

Table 7. General hardware register map (continued)

Address	Block	Register label	Register name	Reset status
0x00 50D3	WWDG	WWDG_CR	WWDG control register	0x7F
0x00 50D4		WWDG_WR	WWDG window register	
0x00 50D5 to 0x00 50D7	Reserved area (11 bytes)			
0x00 50E0	IWDG	IWDG_KR	IWDG key register	0xFF
0x00 50E1		IWDG_PR	IWDG prescaler register	0x00
0x00 50E2		IWDG_RLR	IWDG reload register	0xFF
0x00 50E3 to 0x00 50EF	Reserved area (13 bytes)			
0x00 50F0	AWU	AWU_CSR	AWU control/status register	0x00
0x00 50F1		AWU_APR	AWU asynchronous prescaler buffer register	0x3F
0x00 50F2		AWU_TBR	AWU timebase selection register	0x00
0x00 50F3	BEEP	BEEP_CSR	BEEP control/status register	0x1F
0x00 50F4 to 0x00 51FF	Reserved area (268 bytes)			
0x00 5200	SPI	SPI_CR1	SPI control register 1	0x00
0x00 5201		SPI_CR2	SPI control register 2	0x00
0x00 5202		SPI_ICR	SPI interrupt control register	0x00
0x00 5203		SPI_SR	SPI status register	0x00
0x00 5204		SPI_DR	SPI data register	0x00
0x00 5205 to 0x00 520F	Reserved area (11 bytes)			

Table 7. General hardware register map (continued)

Address	Block	Register label	Register name	Reset status
0x00 5210	I2C	I2C_CR1	I2C control register 1	0x00
0x00 5211		I2C_CR2	I2C control register 2	0x00
0x00 5212		I2C_FREQR	I2C frequency register	0x00
0x00 5213		I2C_OAR1L	I2C own address register 1 low	0x00
0x00 5214		I2C_OAR1H	I2C own address register 1 high	0x00
0x00 5215		I2C_OAR2	I2C own address register 2	0x00
0x00 5216		I2C_DR	I2C data register	0x00
0x00 5217		I2C_SR1	I2C status register 1	0x00
0x00 5218		I2C_SR2	I2C status register 2	0x00
0x00 5219		I2C_SR3	I2C status register 3	0x00
0x00 521A		I2C_ITR	I2C interrupt control register	0x00
0x00 521B		I2C_CCRL	I2C Clock control register low	0x00
0x00 521C		I2C_CCRH	I2C Clock control register high	0x00
0x00 521D		I2C_TRISER	I2C TRISE register	0x00
0x00 521E to 0x00 522F	Reserved area (18 bytes)			
0x00 5230	USART	USART_SR	USART status register	0xC0
0x00 5231		USART_DR	USART data register	0xFF
0x00 5232		USART_BRR1	USART baud rate register 1	0x00
0x00 5233		USART_BRR2	USART baud rate register 2	0x00
0x00 5234		USART_CR1	USART control register 1	0x00
0x00 5235		USART_CR2	USART control register 2	0x00
0x00 5236		USART_CR3	USART control register 3	0x00
0x00 5237		USART_CR4	USART control register 4	0x00
0x00 5238 to 0x00 524F	Reserved area (18 bytes)			

Table 7. General hardware register map (continued)

Address	Block	Register label	Register name	Reset status
0x00 5250	TIM2	TIM2_CR1	TIM2 control register 1	0x00
0x00 5251		TIM2_CR2	TIM2 control register 2	0x00
0x00 5252		TIM2_SMCR	TIM2 slave mode control register	0x00
0x00 5253		TIM2_ETR	TIM2 external trigger register	0x00
0x00 5254		TIM2_IER	TIM2 interrupt enable register	0x00
0x00 5255		TIM2_SR1	TIM2 status register 1	0x00
0x00 5256		TIM2_SR2	TIM2 status register 2	0x00
0x00 5257		TIM2_EGR	TIM2 event generation register	0x00
0x00 5258		TIM2_CCMR1	TIM2 capture/compare mode register 1	0x00
0x00 5259		TIM2_CCMR2	TIM2 capture/compare mode register 2	0x00
0x00 525A		TIM2_CCER1	TIM2 capture/compare enable register 1	0x00
0x00 525B		TIM2_CNTRH	TIM2 counter register high	0x00
0x00 525C		TIM2_CNTRL	TIM2 counter register low	0x00
0x00 525D		TIM2_PSCR	TIM2 prescaler register	0x00
0x00 525E		TIM2_ARRH	TIM2 auto-reload register high	0xFF
0x00 525F		TIM2_ARRL	TIM2 auto-reload register low	0xFF
0x00 5260		TIM2_CCR1H	TIM2 capture/compare register 1 high	0x00
0x00 5261		TIM2_CCR1L	TIM2 capture/compare register 1 low	0x00
0x00 5262		TIM2_CCR2H	TIM2 capture/compare register 2 high	0x00
0x00 5263		TIM2_CCR2L	TIM2 capture/compare register 2 low	0x00
0x00 5264	TIM2_BKR	TIM2 break register	0x00	
0x00 5265	TIM2_OISR	TIM2 output idle state register	0x00	
0x00 5266 to 0x00 527F	Reserved area (26 bytes)			

Table 7. General hardware register map (continued)

Address	Block	Register label	Register name	Reset status
0x00 5280	TIM3	TIM3_CR1	TIM3 control register 1	0x00
0x00 5281		TIM3_CR2	TIM3 control register 2	0x00
0x00 5282		TIM3_SMCR	TIM3 slave mode control register	0x00
0x00 5283		TIM3_ETR	TIM3 external trigger register	0x00
0x00 5284		TIM3_IER	TIM3 interrupt enable register	0x00
0x00 5285		TIM3_SR1	TIM3 status register 1	0x00
0x00 5286		TIM3_SR2	TIM3 status register 2	0x00
0x00 5287		TIM3_EGR	TIM3 event generation register	0x00
0x00 5288		TIM3_CCMR1	TIM3 capture/compare mode register 1	0x00
0x00 5289		TIM3_CCMR2	TIM3 capture/compare mode register 2	0x00
0x00 528A		TIM3_CCER1	TIM3 capture/compare enable register 1	0x00
0x00 528B		TIM3_CNTRH	TIM3 counter register high	0x00
0x00 528C		TIM3_CNTRL	TIM3 counter register low	0x00
0x00 528D		TIM3_PSCR	TIM3 prescaler register	0x00
0x00 528E		TIM3_ARRH	TIM3 auto-reload register high	0xFF
0x00 528F		TIM3_ARRL	TIM3 auto-reload register low	0xFF
0x00 5290		TIM3_CCR1H	TIM3 capture/compare register 1 high	0x00
0x00 5291		TIM3_CCR1L	TIM3 capture/compare register 1 low	0x00
0x00 5292		TIM3_CCR2H	TIM3 capture/compare register 2 high	0x00
0x00 5293		TIM3_CCR2L	TIM3 capture/compare register 2 low	0x00
0x00 5294	TIM3_BKR	TIM3 break register	0x00	
0x00 5295	TIM3_OISR	TIM3 output idle state register	0x00	
0x00 5296 to 0x00 52DF	Reserved area (74 bytes)			
0x00 52E0	TIM4	TIM4_CR1	TIM4 control register 1	0x00
0x00 52E1		TIM4_CR2	TIM4 control register 2	0x00
0x00 52E2		TIM4_SMCR	TIM4 Slave mode control register	0x00
0x00 52E3		TIM4_IER	TIM4 interrupt enable register	0x00
0x00 52E4		TIM4_SR1	TIM4 Status register 1	0x00
0x00 52E5		TIM4_EGR	TIM4 event generation register	0x00
0x00 52E6		TIM4_CNTR	TIM4 counter register	0x00
0x00 52E7		TIM4_PSCR	TIM4 prescaler register	0x00
0x00 52E8		TIM4_ARR	TIM4 auto-reload register low	0xFF

Table 7. General hardware register map (continued)

Address	Block	Register label	Register name	Reset status
0x00 52E9 to 0x00 52FF	Reserved area (23 bytes)			
0x00 5300	PXS	PXS_CR1	ProxSense control register 1	0x00
0x00 5301		PXS_CR2	ProxSense control register 2	0x00
0x00 5302		PXS_CR3	ProxSense control register 3	0x04
0x00 5303		Reserved area (1 byte)		
0x00 5304		PXS_ISR	ProxSense interrupt and status register	0x00
0x00 5305		Reserved area (1 byte)		
0x00 5306		PXS_CKCR1	ProxSense clock control register 1	0x30
0x00 5307		PXS_CKCR2	ProxSense clock control register 2	0x11
0x00 5308		PXS_RXENRH	ProxSense receiver enable register high	0x00
0x00 5309		PXS_RXENRL	ProxSense receiver enable register low	0x00
0x00 5310 to 0x00 5311		Reserved area (2 bytes)		
0x00 530A	PXS	PXS_RXCR1H	ProxSense receiver control register 1 high	0x00
0x00 530B		PXS_RXCR1L	ProxSense receiver control register 1 low	0x00
0x00 530C		PXS_RXCR2H	ProxSense receiver control register 2 high	0x00
0x00 530D		PXS_RXCR2L	ProxSense receiver control register 2 low	0x00
0x00 530E		PXS_RXCR3H	ProxSense receiver control register 3 high	0x00
0x00 530F		PXS_RXCR3L	ProxSense receiver control register 3 low	0x00
0x00 5312		PXS_RXINSRH	ProxSense receiver inactive state register high	0x00
0x00 5313		PXS_RXINSRL	ProxSense receiver inactive state register low	0x00
0x00 5314 to 0x00 5315	Reserved area (2 bytes)			
0x00 5316	PXS	PXS_TXENRH	ProxSense transmit enable register high	0x00
0x00 5317		PXS_TXENRL	ProxSense transmit enable register low	0x00
0x00 5318 to 0x00 5319	Reserved area (2 bytes)			

Table 7. General hardware register map (continued)

Address	Block	Register label	Register name	Reset status
0X00 531A	PXS	PXS_MAXRH	ProxSense maximum counter value register high	0xFF
0x00 531B		PXS_MAXRL	ProxSense maximum counter value register low	0xFF
0x00 531C		PXS_MAXENRH	ProxSense maximum counter enable register high	0x00
0x00 531D		PXS_MAXENRL	ProxSense maximum counter enable register low	0x00
0x00 531E		PXS_RXSRH	ProxSense receiver status register high	0x00
0x00 531F		PXS_RXSRL	ProxSense receiver status register low	0x00
0x00 5320		PXS_RX0CNTRH	ProxSense counter register receiver channel high	0x00
0x00 5321		PXS_RX0CNTRL	ProxSense counter register receiver channel low	0x00
0x00 5322		PXS_RX1CNTRH	ProxSense counter register receiver channel high	0x00
0x00 5323		PXS_RX1CNTRL	ProxSense counter register receiver channel low	0x00
0x00 5324		PXS_RX2CNTRH	ProxSense counter register receiver channel high	0x00
0x00 5325		PXS_RX2CNTRL	ProxSense counter register receiver channel low	0x00
0x00 5326		PXS_RX3CNTRH	ProxSense counter register receiver channel high	0x00
0x00 5327	PXS_RX3CNTRL	ProxSense counter register receiver channel low	0x00	
0x00 5328	PXS_RX4CNTRH	ProxSense counter register receiver channel high	0x00	
0x00 5329	PXS_RX4CNTRL	ProxSense counter register receiver channel low	0x00	
0x00 532A	PXS_RX5CNTRH	ProxSense counter register receiver channel high	0x00	
0x00 532B	PXS_RX5CNTRL	ProxSense counter register receiver channel low	0x00	
0x00 532C	PXS_RX6CNTRH	ProxSense counter register receiver channel high	0x00	
0x00 532D	PXS_RX6CNTRL	ProxSense counter register receiver channel low	0x00	
0x00 532E	PXS_RX7CNTRH	ProxSense counter register receiver channel high	0x00	
0x00 532F	PXS_RX7CNTRL	ProxSense counter register receiver channel low	0x00	
0x00 5330	PXS_RX8CNTRH	ProxSense counter register receiver channel high	0x00	
0x00 5331	PXS_RX8CNTRL	ProxSense counter register receiver channel low	0x00	
0x00 5332	PXS_RX9CNTRH	ProxSense counter register receiver channel high	0x00	
0x00 5333	PXS_RX9CNTRL	ProxSense counter register receiver channel low	0x00	
0x00 5334 to 0x00 533F	Reserved area (12 bytes)			

Table 7. General hardware register map (continued)

Address	Block	Register label	Register name	Reset status
0x00 5340	PXS	PXS_RX0CSSEL	ProxSense receiver sampling capacitor selection register	0x00
0x00 5341		PXS_RX1CSSEL	ProxSense receiver sampling capacitor selection register	0x00
0x00 5342		PXS_RX2CSSEL	ProxSense receiver sampling capacitor selection register	0x00
0x00 5343		PXS_RX3CSSEL	ProxSense receiver sampling capacitor selection register	0x00
0x00 5344		PXS_RX4CSSEL	ProxSense receiver sampling capacitor selection register	0x00
0x00 5345		PXS_RX5CSSEL	ProxSense receiver sampling capacitor selection register	0x00
0x00 5346		PXS_RX6CSSEL	ProxSense receiver sampling capacitor selection register	0x00
0x00 5347		PXS_RX7CSSEL	ProxSense receiver sampling capacitor selection register	0x00
0x00 5348		PXS_RX8CSSEL	ProxSense receiver sampling capacitor selection register	0x00
0x00 5349		PXS_RX9CSSEL	ProxSense receiver sampling capacitor selection register	0x00
0x00 534A to 0x00 534F	Reserved area (6 bytes)			

Table 7. General hardware register map (continued)

Address	Block	Register label	Register name	Reset status
0x00 5350	PXS	PXS_RX0EPCCSELR	ProxSense receiver electrode parasitic compensation capacitor selection register	0x00
0x00 5351		PXS_RX1EPCCSELR	ProxSense receiver electrode parasitic compensation capacitor selection register	0x00
0x00 5352		PXS_RX2EPCCSELR	ProxSense receiver electrode parasitic compensation capacitor selection register	0x00
0x00 5353		PXS_RX3EPCCSELR	ProxSense receiver electrode parasitic compensation capacitor selection register	0x00
0x00 5354		PXS_RX4EPCCSELR	ProxSense receiver electrode parasitic compensation capacitor selection register	0x00
0x00 5355		PXS_RX5EPCCSELR	ProxSense receiver electrode parasitic compensation capacitor selection register	0x00
0x00 5356		PXS_RX6EPCCSELR	ProxSense receiver electrode parasitic compensation capacitor selection register	0x00
0x00 5357		PXS_RX7EPCCSELR	ProxSense receiver electrode parasitic compensation capacitor selection register	0x00
0x00 5358		PXS_RX8EPCCSELR	ProxSense receiver electrode parasitic compensation capacitor selection register	0x00
0x00 5359		PXS_RX9EPCCSELR	ProxSense receiver electrode parasitic compensation capacitor selection register	0x00
0x00 535A to 0x00 7EFF	Reserved area (11174 bytes)			

1. After power-on reset.

Table 8. CPU/SWIM/debug module/interrupt controller registers

Address	Block	Register label	Register name	Reset status
0x00 7F00	CPU	A	Accumulator	0x00
0x00 7F01		PCE	Program counter extended	0x00
0x00 7F02		PCH	Program counter high	0x80
0x00 7F03		PCL	Program counter low	0x00
0x00 7F04		XH	X index register high	0x00
0x00 7F05		XL	X index register low	0x00
0x00 7F06		YH	Y index register high	0x00
0x00 7F07		YL	Y index register low	0x00
0x00 7F08		SPH	Stack pointer high	0x05
0x00 7F09		SPL	Stack pointer low	0xFF
0x00 7F0A		CC	Condition code register	0x28

Table 8. CPU/SWIM/debug module/interrupt controller registers (continued)

Address	Block	Register label	Register name	Reset status
0x00 7F0B to 0x00 7F5F	Reserved area (85 bytes)			
0x00 7F60	CFG	CFG_GCR	Global configuration register	0x00
0x00 7F61 0x00 7F6F	Reserved area (15 bytes)			
0x00 7F70	ITC-SPR (1)	ITC_SPR1	Interrupt Software priority register 1	0xFF
0x00 7F71		ITC_SPR2	Interrupt Software priority register 2	0xFF
0x00 7F72		ITC_SPR3	Interrupt Software priority register 3	0xFF
0x00 7F73		ITC_SPR4	Interrupt Software priority register 4	0xFF
0x00 7F74		ITC_SPR5	Interrupt Software priority register 5	0xFF
0x00 7F75		ITC_SPR6	Interrupt Software priority register 6	0xFF
0x00 7F76		ITC_SPR7	Interrupt Software priority register 7	0xFF
0x00 7F77		ITC_SPR8	Interrupt Software priority register 8	0xFF
0x00 7F78 to 0x00 7F79	Reserved area (2 bytes)			
0x00 7F80	SWIM	SWIM_CSR	SWIM control status register	0x00
0x00 7F81 to 0x00 7F8F	Reserved area (15 bytes)			
0x00 7F90	DM	DM_BK1RE	Breakpoint 1 register extended byte	0xFF
0x00 7F91		DM_BK1RH	Breakpoint 1 register high byte	0xFF
0x00 7F92		DM_BK1RL	Breakpoint 1 register low byte	0xFF
0x00 7F93		DM_BK2RE	Breakpoint 2 register extended byte	0xFF
0x00 7F94		DM_BK2RH	Breakpoint 2 register high byte	0xFF
0x00 7F95		DM_BK2RL	Breakpoint 2 register low byte	0xFF
0x00 7F96		DM_CR1	Debug module control register 1	0x00
0x00 7F97		DM_CR2	Debug module control register 2	0x00
0x00 7F98		DM_CSR1	Debug module control/status register 1	0x10
0x00 7F99		DM_CSR2	Debug module control/status register 2	0x00
0x00 7F9A		DM_ENFCTR	Enable function register	0xFF

1. Refer to [Table 7: General hardware register map on page 28](#) (addresses 0x00 50A0 to 0x00 50A5) for a list of external interrupt registers.

6 Interrupt vector mapping

Table 9. Interrupt mapping

IRQ No.	Source block	Description	Wakeup from Halt mode	Wakeup from Active-halt mode	Wakeup from Wait (WFI mode)	Wakeup from Wait (WFE mode) ⁽¹⁾	Vector address
	RESET	Reset	Yes	Yes	Yes	Yes	0x00 8000
	TRAP	Software interrupt	-	-	-	-	0x00 8004
0	Reserved						0x00 8008
1	FLASH	FLASH end of programing/ write attempted to protected page interrupt	-	-	Yes	Yes	0x00 800C
2	PXS	End of conversion/First conversion completed	-	Yes ⁽²⁾	Yes	Yes	0x00 8010
3	Reserved						0x00 8011 -0x00 8017
4	AWU	Auto wakeup from Halt	-	Yes	Yes	Yes	0x00 8018
5	Reserved						0x00 801C
6	EXTIB	External interrupt port B	Yes	Yes	Yes	Yes	0x00 8020
7	EXTID	External interrupt port D	Yes	Yes	Yes	Yes	0x00 8024
8	EXTI0	External interrupt 0	Yes	Yes	Yes	Yes	0x00 8028
9	EXTI1	External interrupt 1	Yes	Yes	Yes	Yes	0x00 802C
10	EXTI2	External interrupt 2	Yes	Yes	Yes	Yes	0x00 8030
11	EXTI3	External interrupt 3	Yes	Yes	Yes	Yes	0x00 8034
12	EXTI4	External interrupt 4	Yes	Yes	Yes	Yes	0x00 8038
13	EXTI5	External interrupt 5	Yes	Yes	Yes	Yes	0x00 803C
14	EXTI6	External interrupt 6	Yes	Yes	Yes	Yes	0x00 8040
15	EXTI7	External interrupt 7	Yes	Yes	Yes	Yes	0x00 8044
16	Reserved						0x00 8048
17	Reserved						0x00 804C -0x00 804F
18	Reserved						0x00 8050
19	TIM2	TIM2 update/overflow/trigger/break interrupt	-	-	Yes	Yes	0x00 8054
20	TIM2	TIM2 capture/compare interrupt	-	-	Yes	Yes	0x00 8058
21	TIM3	TIM3 update/overflow/trigger/break interrupt	-	-	Yes	Yes	0x00 805C

Table 9. Interrupt mapping (continued)

IRQ No.	Source block	Description	Wakeup from Halt mode	Wakeup from Active-halt mode	Wakeup from Wait (WFI mode)	Wakeup from Wait (WFE mode) ⁽¹⁾	Vector address
22	TIM3	TIM3 capture/compare interrupt	-	-	Yes	Yes	0x00 8060
23-24	Reserved						0x00 8064-0x00 806B
25	TIM4	TIM4 update/overflow/trigger interrupt	-	-	Yes	Yes	0x00 806C
26	SPI	SPI TX buffer empty/RX buffer not empty/error/wakeup interrupt	Yes	Yes	Yes	Yes	0x00 8070
27	USART	USART transmit data register empty/transmission complete interrupt	-	-	Yes	Yes	0x00 8074
28	USART	USART received data ready/overrun error/idle line detected/parity error/global error interrupt	-	-	Yes	Yes	0x00 8078
29	I2C	I2C interrupt ⁽³⁾	Yes	Yes	Yes	Yes	0x00 807C

1. The Low power wait mode is entered when executing a WFE instruction in Low power run mode. In WFE mode, the interrupt is served if it has been previously enabled. After processing the interrupt, the processor goes back to WFE mode. When the interrupt is configured as a wakeup event, the CPU wakes up and resumes processing.
2. ProxSense activated before executing HALT instruction.
3. The device is woken up from Halt or Active-halt mode only when the address received matches the interface address.

7 Option bytes

Option bytes contain configurations for device hardware features as well as the memory protection of the device. They are stored in a dedicated row of the memory.

All option bytes can be modified only in ICP mode (with SWIM) by accessing the EEPROM address. See [Table 10](#) for details on option byte addresses.

Refer to the STM8TL5xxx Flash programming manual (PM0212) and STM8 SWIM and debug manual (UM0470) for information on SWIM programming procedures.

Table 10. Option bytes

Addr.	Option name	Option byte No.	Option bits								Factory default setting
			7	6	5	4	3	2	1	0	
0x4800	Read-out protection (ROP)	OPT0	ROP[7:0]								0xAA
0x4801	-	-	Must be programmed to 0x00								0x00
0x4802	User Boot code size (UBC)	OPT1	UBC[7:0]								0x00
0x4803	DATASIZE	OPT2	DATASIZE[7:0]								0x00
0x4807	PCODESIZE	OPT3	PCODESIZE[7:0]								0x00
0x4808	Window watchdog and independent window watchdog	OPT4 [3:0]	Reserved				WWDG _HALT	WWDG _HW	IWDG _HALT	IWDG _HW	0x00

Table 11. Option byte description

Option byte number	Description
OPT0	<p>ROP[7:0] <i>Memory readout protection (ROP)</i></p> <p>0xAA: Readout protection disabled (write access via SWIM protocol) Refer to Read-out protection section in the STM8TL5xxx reference manual (RM0312) for details.</p>
OPT1	<p>UBC[7:0] <i>Size of the user boot code area</i></p> <p>0x00: no UBC 0x01-0x02: UBC contains only the interrupt vectors. 0x03: Page 0 and 1 reserved for the interrupt vectors. Page 2 is available to store user boot code. Memory is write protected ... 0xFF: Page 0 to 254 reserved for UBC, memory is write protected Refer to User boot area (UBC) section in the STM8TL5xxx reference manual (RM0312) for more details.</p>

Table 11. Option byte description (continued)

Option byte number	Description
OPT2	<p>DATASIZE[7:0] Size of the data EEPROM area 0x00: no data EEPROM area 0x01: 1 page reserved for data storage from 0xBFC0 to 0xBFFF 0x02: 2 pages reserved for data storage from 0xBF80 to 0xBFFF ... 0x20: 32 pages reserved for data storage from 0xB800 to 0xBFFF Refer to Data EEPROM (DATA) section in the STM8TL5xxx reference manual (RM0312) for more details.</p>
OPT3	<p>PCODESIZE[7:0] Size of the proprietary code area 0x00: No proprietary code area 0x03: TRAP vector and page 2 (0x8080 to 0x80BF) reserved for the proprietary code and read/write protected ... 0xFF: TRAP vector and page 2 to 254 (0x8080 to 0xBFBF) reserved for the proprietary code and read/write protected Refer to Proprietary code area (PCODE) section in the STM8TLxxxx Programming Manual(PM0212) for more details.</p>
OPT4	<p>IWDG_HW: <i>Independent watchdog</i> 0: Independent watchdog activated by software 1: Independent watchdog activated by hardware</p>
	<p>IWDG_HALT: <i>Independent window watchdog reset on Halt/Active-halt</i> 0: Independent watchdog continues running in Halt/Active-halt mode 1: Independent watchdog stopped in Halt/Active-halt mode</p>
	<p>WWDG_HW: <i>Window watchdog</i> 0: Window watchdog activated by software 1: Window watchdog activated by hardware</p>
	<p>WWDG_HALT: <i>Window watchdog reset on Halt/Active-halt</i> 0: Window watchdog stopped in Halt/Active-halt mode 1: Window watchdog continues running in Halt/Active-halt mode</p>

Caution: After a device reset, read access to the program memory is not guaranteed if address 0x4807 is not programmed to 0x00.

8 Unique ID

STM8TL5xx4 devices feature a 96-bit unique device identifier which provides a reference number that is unique for any device and in any context. The 96 bits of the identifier can never be altered by the user.

The unique device identifier can be read in single bytes and may then be concatenated using a custom algorithm.

The unique device identifier is ideally suited:

- For use as serial numbers
- For use as security keys to increase the code security in the program memory while using and combining this unique ID with software cryptographic primitives and protocols before programming the internal memory
- To activate secure boot processes

Table 12. Unique ID registers (96 bits)

Address	Content description	Unique ID bits							
		7	6	5	4	3	2	1	0
0x4925	X coordinate on the wafer	U_ID[7:0]							
0x4926		U_ID[15:8]							
0x4927	Y coordinate on the wafer	U_ID[23:16]							
0x4928		U_ID[31:24]							
0x4929	Wafer number	U_ID[39:32]							
0x492A	Lot number	U_ID[47:40]							
0x492B		U_ID[55:48]							
0x492C		U_ID[63:56]							
0x492D		U_ID[71:64]							
0x492E		U_ID[79:72]							
0x492F		U_ID[87:80]							
0x4930		U_ID[95:88]							

9 Electrical parameters

9.1 Parameter conditions

Unless otherwise specified, all voltages are referred to V_{SS} .

9.1.1 Minimum and maximum values

Unless otherwise specified, the minimum and maximum values are guaranteed in the worst conditions of ambient temperature, supply voltage and frequencies by tests in production on 100% of the devices with an ambient temperature of $T_A = 25\text{ °C}$ and $T_A = T_A \text{ max}$ (given by the selected temperature range).

Data based on characterization results, design simulation and/or technology characteristics are indicated in the table footnotes and are not tested in production. Based on characterization, the minimum and maximum values refer to sample tests and represent the mean value plus or minus three times the standard deviation ($\text{mean} \pm 3\sigma$).

9.1.2 Typical values

Unless otherwise specified, typical data are based on $T_A = 25\text{ °C}$, $V_{DD} = 3\text{ V}$. They are given only as design guidelines and are not tested.

9.1.3 Typical curves

Unless otherwise specified, all typical curves are given only as design guidelines and are not tested.

9.1.4 Loading capacitor

The loading conditions used for pin parameter measurement are shown in [Figure 8](#).

Figure 8. Pin loading conditions

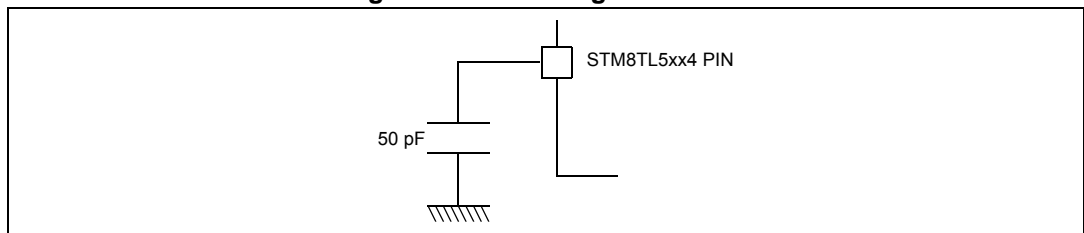

9.1.5 Pin input voltage

The input voltage measurement on a pin of the device is described in [Figure 9](#).

Figure 9. Pin input voltage

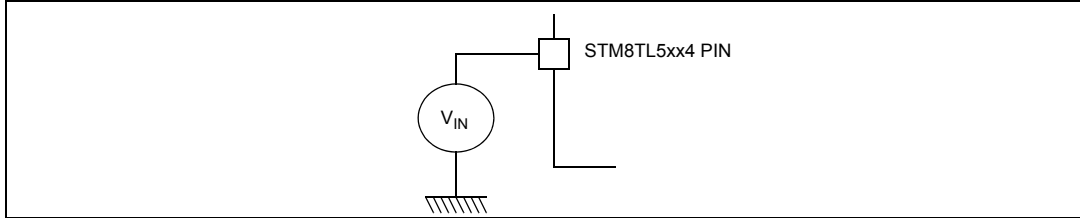

9.2 Absolute maximum ratings

Stresses above those listed as “absolute maximum ratings” may cause permanent damage to the device. This is a stress rating only and functional operation of the device under these conditions is not implied. Exposure to maximum rating conditions for extended periods may affect device reliability.

Table 13. Voltage characteristics

Symbol	Ratings	Min	Max	Unit
$V_{DD} - V_{SS}$	External supply voltage (including V_{DD} and V_{DDIO}) ⁽¹⁾	-0.3	4.0	V
$V_{IN}^{(2)}$	Receiver channel pins (PXS_Rx0a...Rx9b)	$V_{SS} - 0.3$	PXS_V_{REG} (~1.45)	
	Input voltage on PB0...7 and PD0...7 ⁽³⁾	Pins used as General purpose I/O	4.0	
		Pins used as transmitter channel pins (PXS_Tx0 to PXS_Tx15)	$V_{SS} - 0.3$	
	Input voltage on any PA pins	$V_{SS} - 0.3$	4.0	
V_{ESD}	Electrostatic discharge voltage	see Absolute maximum ratings (electrical sensitivity) on page 69		

1. All power (V_{DD} , V_{DDIO}) and ground (V_{SS} , V_{SSIO}) pins must always be connected to the external power supply.
2. V_{IN} maximum must always be respected. Refer to [Table 14](#) for maximum allowed injected current values.
3. Current injection on these pins is not allowed.

Table 14. Current characteristics

Symbol	Ratings	Max.	Unit
I_{VDD}	Total current into V_{DD} power line (source)	80	mA
I_{VSS}	Total current out of V_{SS} ground line (sink)	80	
I_{IO}	Output current sunk by any other I/O and control pin	25	
	Output current source by any I/Os and control pin	-25	
$I_{INJ(PIN)}^{(1)}$	Injected current on PA pins ⁽²⁾	±5	
$I_{INJ(PIN)}$	Injected current on PB pins	0	
$I_{INJ(PIN)}$	Injected current on PD pins	0	
$\Sigma I_{INJ(PIN)}^{(1)}$	Total injected current (sum of all I/O and control pins) ⁽²⁾	±25	

- $I_{INJ(PIN)}$ must never be exceeded. This is implicitly insured if V_{IN} maximum is respected. If V_{IN} maximum cannot be respected, the injection current must be limited externally to the $I_{INJ(PIN)}$ value. A positive injection is induced by $V_{IN} > V_{DD}$ while a negative injection is induced by $V_{IN} < V_{SS}$. For true open-drain pads, there is no positive injection current, and the corresponding V_{IN} maximum must always be respected.
- When several inputs are submitted to a current injection, the maximum $\Sigma I_{INJ(PIN)}$ is the absolute sum of the positive and negative injected currents (instantaneous values). These results are based on characterization with $\Sigma I_{INJ(PIN)}$ maximum current injection on four I/O port pins of the device.

Table 15. Thermal characteristics

Symbol	Ratings	Min	Unit
T_{STG}	Storage temperature range	-65 to +150	°C
T_J	Maximum junction temperature	150	

9.3 Operating conditions

Subject to general operating conditions for V_{DD} and T_A .

9.3.1 General operating conditions

Table 16. General operating conditions

Symbol	Parameter	Conditions	Min	Max	Unit
$f_{MASTER}^{(1)}$	Master clock frequency	$1.65\text{ V} \leq V_{DD} < 3.6\text{ V}$	2	16	MHz
V_{DD}	Standard operating voltage	-	1.65	3.6	V
$P_D^{(2)}$	Power dissipation at $T_A = 85\text{ °C}$ for suffix 2 devices	UQFPN48	-	625	mW
		UQFPN28	-	250	
		TSSOP20	-	180	
T_A	Temperature range	$1.65\text{ V} \leq V_{DD} < 3.6\text{ V}$	-40	85	°C
T_J	Junction temperature range	$-40\text{ °C} \leq T_A \leq 85\text{ °C}$	-40	105	

- $f_{MASTER} = f_{CPU}$.
- To calculate $P_{Dmax}(T_A)$ use the formula given in thermal characteristics $P_{Dmax} = (T_{Jmax} - T_A) / \Theta_{JA}$ with T_{Jmax} in this table and Θ_{JA} in table "Thermal characteristics".

9.3.2 Power supply

Figure 10. Power supply scheme

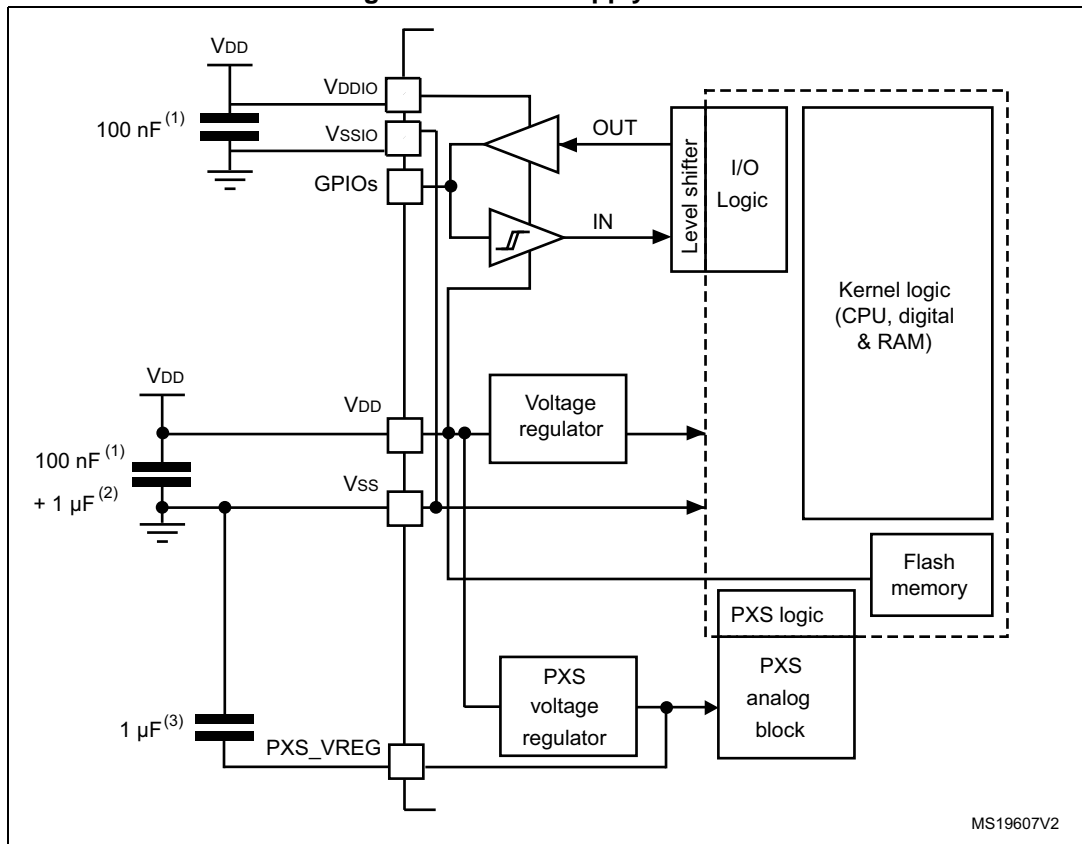

1. Each power supply pair must be decoupled with filtering ceramic capacitors as shown above. These capacitors must be placed as close as possible to, or below, the appropriate pins to ensure the correct functionality of the device.
2. The 1μF capacitor must be connected to the V_{DD} pin.
3. The 1μF ceramic capacitor connected to PXS_VREG must be low ESR (ESR ≤ 1Ω).

9.3.3 Power-up / power-down operating conditions

Table 17. Operating conditions at power-up / power-down

Symbol	Parameter	Conditions	Min.	Typ.	Max.	Unit
t _{VDD}	V _{DD} rise time rate		20	-	1300	μs/V
t _{TEMP}	Reset release delay	V _{DD} rising	-	1	-	ms
V _{POR}	Power on reset threshold		1.44 ⁽²⁾	-	1.65 ⁽¹⁾	V
V _{PDR}	Power down reset threshold		1.30 ⁽²⁾	-	1.60 ⁽²⁾	V

1. Tested in production.
2. Data based on characterization results, not tested in production.

9.3.4 ProxSense Regulator Voltage

Table 18. ProxSense voltage regulator characteristics

Symbol	Parameter	Conditions	Min.	Typ.	Max.	Unit
$C_{reg}^{(1)}$	Voltage regulator decoupling capacitance ⁽²⁾	-	0.5	1	10	μF
V_{reg}	Regulated voltage during acquisition	-	-	1.45	-	V

1. The capacitor must be routed as close as PXS_VREG as possible ($\leq 1\text{cm}$)
2. Equivalent serial resistor $\leq 1\Omega$

9.3.5 Supply current characteristics

Total current consumption

The MCU is placed under the following conditions:

- All I/O pins in input mode with a static value at V_{DD} or V_{SS} (no load)
- All peripherals are disabled except if explicitly mentioned

Subject to general operating conditions for V_{DD} and T_A .

Table 19. Total current consumption in Run mode ⁽¹⁾

Symbol	Parameter	Conditions ⁽²⁾		Typ.	Max. ⁽³⁾	Unit
$I_{DD (Run)}$	Supply current in Run mode	Code executed from RAM	$f_{MASTER} = 2\text{ MHz}$	0.4	0.6	mA
			$f_{MASTER} = 4\text{ MHz}$	0.55	0.7	
			$f_{MASTER} = 8\text{ MHz}$	0.9	1.2	
			$f_{MASTER} = 16\text{ MHz}$	1.6	2.1 ⁽⁴⁾	
		Code executed from Flash	$f_{MASTER} = 2\text{ MHz}$	0.56	0.7	
			$f_{MASTER} = 4\text{ MHz}$	0.88	1.8	
			$f_{MASTER} = 8\text{ MHz}$	1.5	2.5	
			$f_{MASTER} = 16\text{ MHz}$	2.8	3.5	

1. Based on characterization results, unless otherwise specified.
2. All peripherals off, V_{DD} from 1.65 V to 3.6 V, HSI internal RC oscillator, $f_{CPU}=f_{MASTER}$.
3. Maximum values are given for $T_A = -40$ to $85\text{ }^\circ\text{C}$.
4. Tested in production.

Figure 11. $I_{DD(RUN)}$ vs. V_{DD} , $f_{CPU} = 16\text{ MHz}$

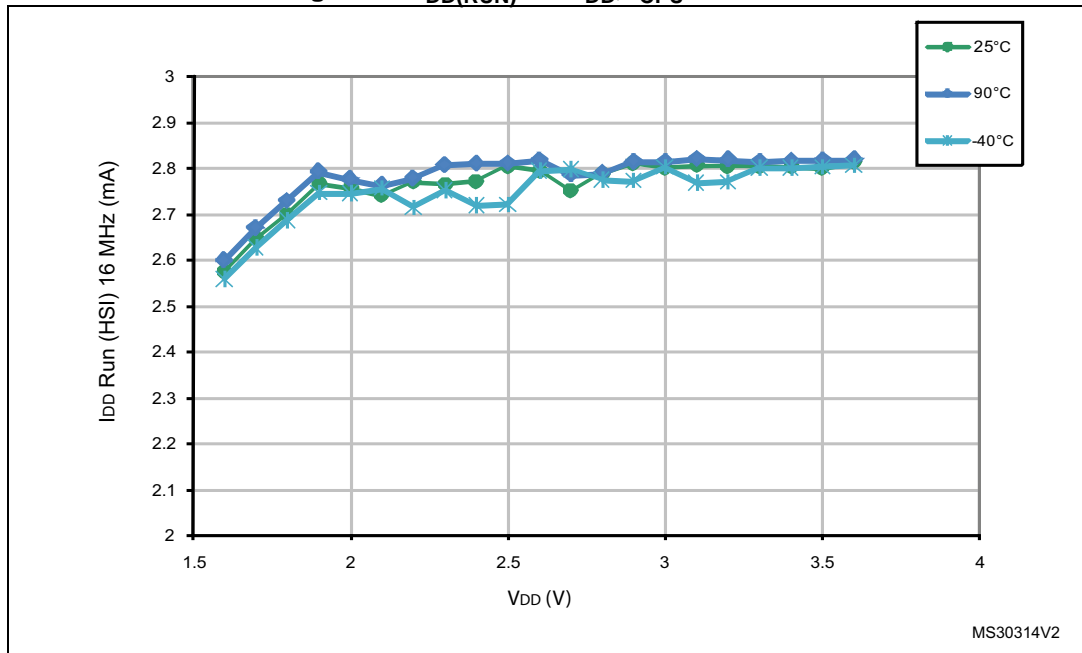

1. Typical current consumption measured with code executed from Flash.

Table 20. Total current consumption in Wait mode⁽¹⁾

Symbol	Parameter	Conditions	Typ.	Max. ⁽²⁾	Unit	
$I_{DD(Wait)}$	Supply current in Wait mode	CPU not clocked, all peripherals off, HSI internal RC osc	$f_{MASTER} = 2\text{ MHz}$	260	400	μA
			$f_{MASTER} = 4\text{ MHz}$	300	450	
			$f_{MASTER} = 8\text{ MHz}$	380	600	
			$f_{MASTER} = 16\text{ MHz}$	500	800	

- Based on characterization results, unless otherwise specified.
- Maximum values are given for $T_A = -40\text{ to }85\text{ }^\circ\text{C}$.

Figure 12. $I_{DD(Wait)}$ vs. V_{DD} . $f_{CPU} = 16\text{ MHz}$

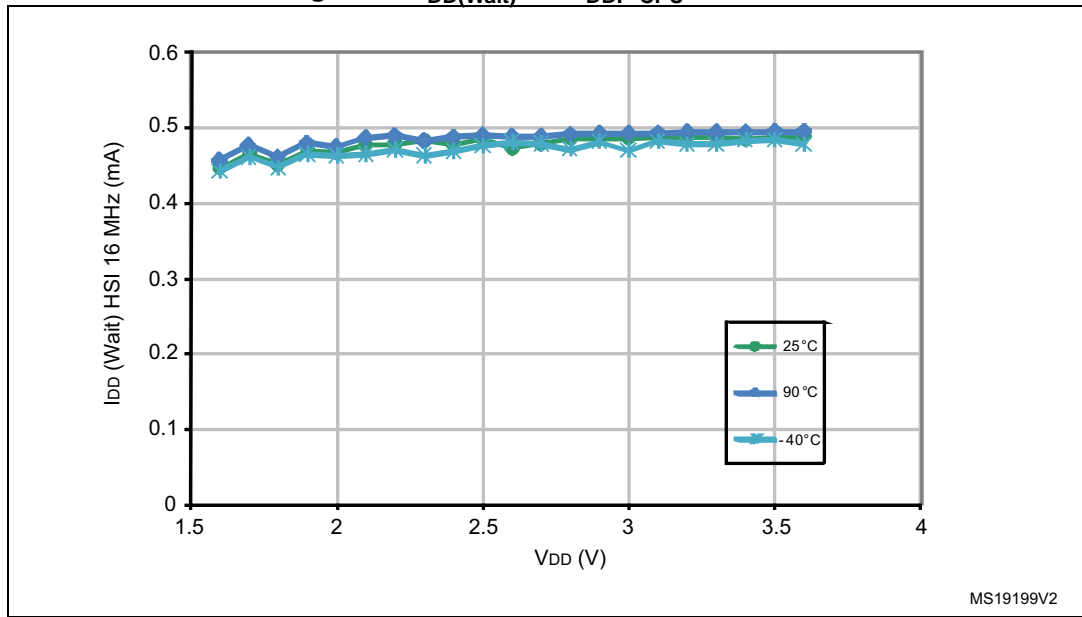

1. Typical current consumption measured with code executed from RAM.

Table 21. Total current consumption in Halt mode and Active-halt mode
 $V_{DD} = 1.65\text{ V to }3.6\text{ V}^{(1) (2)}$

Symbol	Parameter	Conditions	Typ.	Max.	Unit	
$I_{DD(AH)}$	Supply current in Active-halt mode	LSI RC osc. (at 38 kHz)	$T_A = -40\text{ °C to }25\text{ °C}$	1	2	μA
			$T_A = 85\text{ °C}$	1.4	3.2	μA
$I_{DD(WUProx)}$	Supply current during wakeup time from Active halt mode (using HSI)	$f_{CPU} = 16\text{ MHz}$	2	-	mA	
$t_{WU(AH)}^{(3)}$	Wakeup time from Active-halt mode to Run mode	$f_{CPU} = 16\text{ MHz}$	4	6.5	μs	
$I_{DD(Halt)}$	Supply current in Halt mode	$T_A = -40\text{ °C to }25\text{ °C}$	0.4	1.2 ⁽⁴⁾	μA	
		$T_A = 85\text{ °C}$	1	2.5 ⁽⁴⁾	μA	
$I_{DD(WUFH)}$	Supply current during wakeup time from Halt mode	$f_{CPU} = 16\text{ MHz}$	2	-	mA	
$t_{WU(Halt)}$	Wakeup time from Halt mode to Run mode	$f_{CPU} = 16\text{ MHz}$	4	6.5	μs	

1. $T_A = -40$ to 85 °C , no floating I/O, unless otherwise specified.
2. Data based on characterization, not tested in production.
3. Measured from interrupt event to interrupt vector fetch. To get t_{WU} for another CPU frequency use $t_{WU}(FREQ) = t_{WU}(16\text{ MHz}) + 1.5 (T_{FREQ} - T_{16\text{ MHz}})$. The first word of interrupt routine is fetched 5 CPU cycles after t_{WU} .
4. Tested in production.

Figure 13. Typ. $I_{DD(Halt)}$ vs. V_{DD} . $f_{CPU} = 2\text{ MHz}$ and 16 MHz

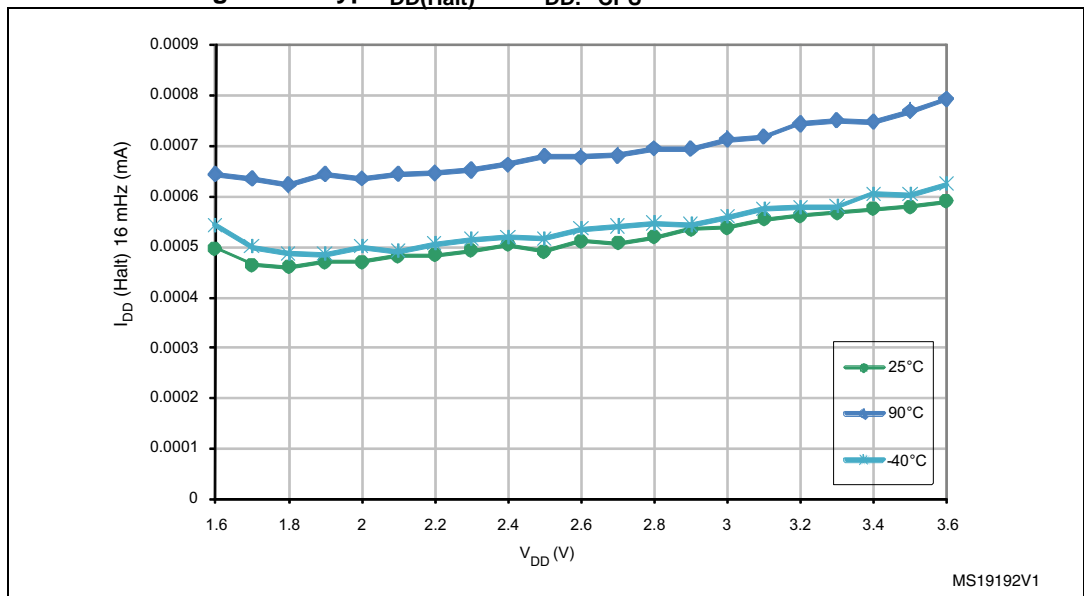

1. Typical current consumption measured with code executed from Flash.

Current consumption of on-chip peripherals

Measurement made for $f_{MASTER} =$ from 2 MHz to 16 MHz

Table 22. Peripheral current consumption

Symbol	Parameter	Typ. $V_{DD} = 3.0 V$	Unit
$I_{DD}(TIM2)$	TIM2 supply current ⁽¹⁾	9	μA/MHz
$I_{DD}(TIM3)$	TIM3 supply current ⁽¹⁾	9	
$I_{DD}(TIM4)$	TIM4 timer supply current ⁽¹⁾	4	
$I_{DD}(USART)$	USART supply current ⁽²⁾	7	
$I_{DD}(SPI)$	SPI supply current ⁽²⁾	4	
$I_{DD}(I^2C)$	I2C supply current ⁽²⁾	4	

1. Data based on a differential I_{DD} measurement between all peripherals off and a timer counter running at 16 MHz. The CPU is in Wait mode in both cases. No IC/OC programmed, no I/O pin toggling. Not tested in production.
2. Data based on a differential I_{DD} measurement between the on-chip peripheral when kept under reset and not clocked and the on-chip peripheral when clocked and not kept under reset. The CPU is in Wait mode in both cases. No I/O pin toggling. Not tested in production.

Current consumption with ProxSense peripherals

Measurement made for $f_{MASTER} = 16 MHz$, $f_{ProxSense} = 16 MHz$, all other peripherals off and under the following conditions:

PXS_Rx*i*CSSELR (Sampling Capacitor) = 0x10

PXS_Rx*i*EPCCSELR (Electrode Parasitic Capacitance Compensation) = 0x80

Capacitance between Tx and Rx of 10nF

Table 23. ProxSense peripheral current consumption⁽¹⁾

Symbol	ProxSense transmitter Tx	ProxSense receiver Rx	Typical	Unit
$I_{DD}(PXS)$	1	1	0.6	mA
	1	4	1.1	
	1	10	2.3	

1. Data based on characterization, not tested in production

9.3.6 Clock and timing characteristics

Internal clock source

The parameters given in [Table 24](#) are derived from tests performed under ambient temperature and V_{DD} supply voltage. They are subject to general operating conditions for V_{DD} and T_A .

High speed internal RC oscillator

Table 24. HSI oscillator characteristics⁽¹⁾

Symbol	Parameter	Conditions	Min.	Typ.	Max.	Unit
f_{HSI}	Frequency	$V_{DD} = 3.0\text{ V}$	-	16	-	MHz
ACC_{HSI}	Accuracy of HSI oscillator (factory calibrated)	$V_{DD} = 3.0\text{ V}, T_A = 25\text{ }^\circ\text{C}$	-1	-	1	%
		$1.65\text{ V} \leq V_{DD} \leq 3.6\text{ V}, T_A = -40\text{ to }85\text{ }^\circ\text{C}$	-3	-	3	%
$I_{DD(HSI)}$	HSI oscillator power consumption		-	70	100	μA

1. $V_{DD} = 3\text{V}, T_A = -40\text{ to }125\text{ }^\circ\text{C}$, unless otherwise specified.

Figure 14. Typical HSI frequency vs. V_{DD}

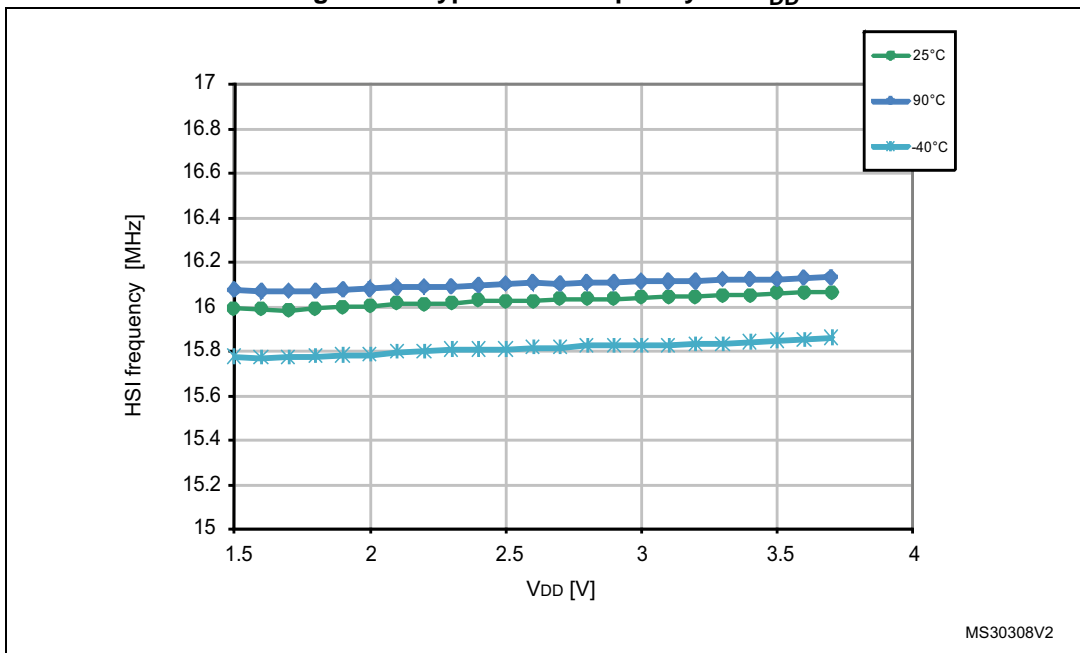

MS30308V2

Figure 15. Typical HSI accuracy vs. temperature, VDD = 3 V

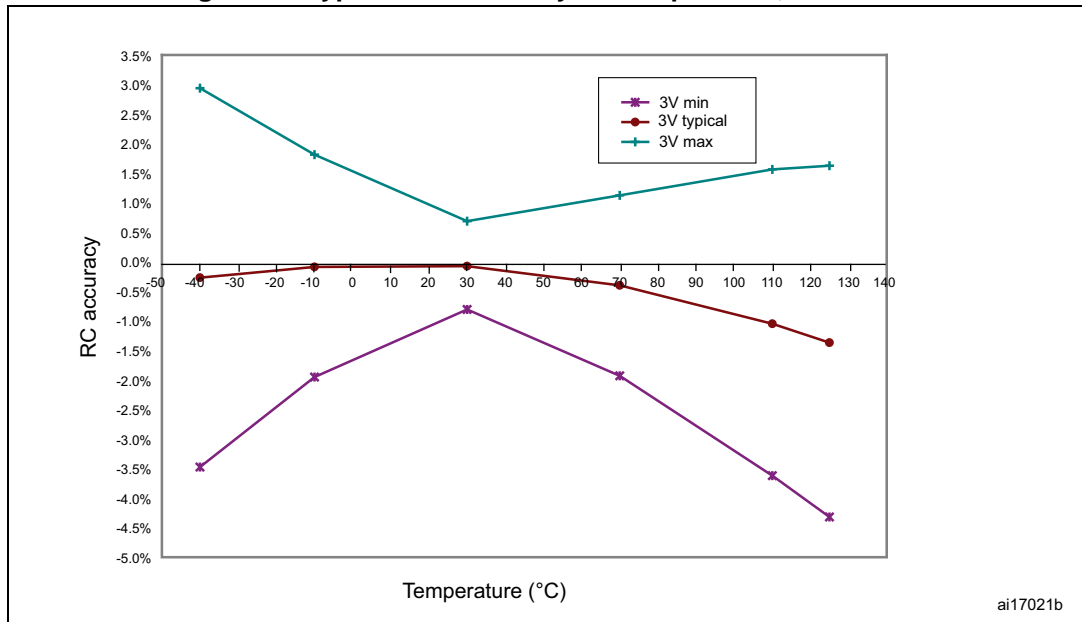

High speed ProxSense RC oscillator

Table 25. HSI_PXS oscillator characteristics⁽¹⁾

Symbol	Parameter	Conditions	Min.	Typ.	Max.	Unit
f _{HSI_PXS}	Frequency	V _{DD} = 3.0 V	-	16	-	MHz

1. V_{DD} = 3V, T_A = -40 to 85 °C, unless otherwise specified.

Low speed internal RC oscillator (LSI)

Table 26. LSI oscillator characteristics⁽¹⁾

Symbol	Parameter	Conditions	Min.	Typ.	Max.	Unit
f _{LSI}	Frequency		26	38	56	kHz
f _{drift(LSI)}	LSI oscillator frequency drift ⁽²⁾	0 °C ≤ T _A ≤ 85°C	-12	-	11	%

1. V_{DD} = 1.65 V to 3.6 V, T_A = -40 to 85°C unless otherwise specified.

2. For each individual part, this value is the frequency drift from the initial measured frequency.

Figure 16. Typical LSI frequency vs. V_{DD}

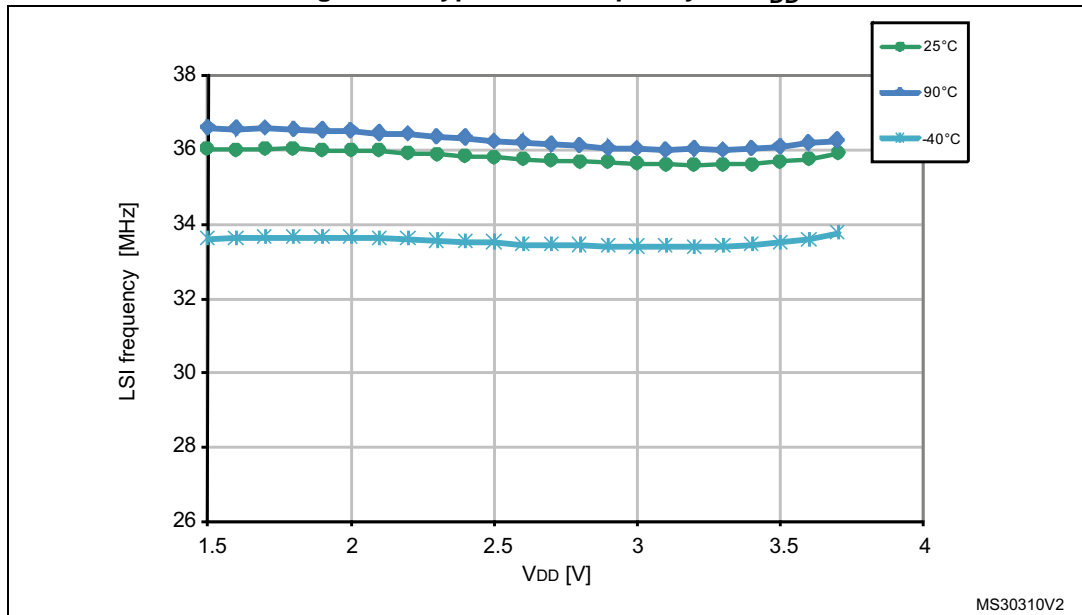

9.3.7 Memory characteristics

T_A = -40 to 85°C unless otherwise specified.

RAM characteristics

Table 27. RAM and hardware registers

Symbol	Parameter	Conditions	Min.	Typ.	Max.	Unit
V _{RM}	Data retention mode ⁽¹⁾	Halt mode (or Reset)	1.4	-	-	V

1. Minimum supply voltage without losing data stored in RAM (in Halt mode or under Reset) or in hardware registers (only in Halt mode). Guaranteed by characterization, not tested in production.

Flash memory characteristics

Table 28. Flash program memory

Symbol	Parameter	Conditions	Min.	Typ.	Max. ⁽¹⁾	Unit
V _{DD}	Operating voltage (all modes, read/write/erase)	f _{MASTER} = 16 MHz	1.65	-	3.6	V
t _{prog}	Programming time for 1 or 64 bytes (block) erase/write cycles (on programmed byte)		-	6	-	ms
	Programming time for 1 to 64 bytes (block) write cycles (on erased byte)		-	3	-	ms
I _{prog}	Programming/ erasing consumption	T _A =+25 °C, V _{DD} = 3.0 V	-	0.7	-	mA
		T _A =+25 °C, V _{DD} = 1.8 V	-		-	

1. Data based on characterization results, not tested in production.

Table 29. Program memory endurance and retention

Parameter	Conditions	Min.	Typ.	Max.	Unit
Endurance	$T_A = -40$ to 85°C	$10^{(1)}$	-	-	kcycles
Data retention	10 kcycles at $T_A = 85^\circ\text{c}$	$30^{(1)}$	-	-	Years

1. Data based on characterization results, not tested in production.

Table 30. Data memory endurance and retention

Parameter	Conditions	Min.	Typ.	Max.	Unit
Endurance	$T_A = -40$ to 85°C	$300^{(1)(2)}$	-	-	kcycles
Data retention	300 kcycles at $T_A = 85^\circ\text{c}$	$30^{(1)}$	-	-	Years

1. Data based on characterization results, not tested in production.

2. Data based on characterization performed on the whole data memory (2 Kbytes).

9.3.8 I/O port pin characteristics

General characteristics

Subject to general operating conditions for V_{DD} and T_A unless otherwise specified. All unused pins must be kept at a fixed voltage: using the output mode of the I/O for example or an external pull-up or pull-down resistor.

Table 31. I/O static characteristics (1)

Symbol	Parameter	Conditions	Min.	Typ.	Max.	Unit
V_{IL}	Input low level voltage ⁽²⁾	Standard I/Os	$V_{SS}-0.3$	-	$0.3 \times V_{DD}$	V
V_{IH}	Input high level voltage ⁽²⁾	Standard I/Os	$0.70 \times V_{DD}$	-	$V_{DD}+0.3$	
V_{hys}	Schmitt trigger voltage hysteresis ⁽³⁾	Standard I/Os	-	200	-	mV
I_{lkg}	Input leakage current ⁽⁴⁾	$V_{SS} \leq V_{IN} \leq V_{DD}$	-	-	50	nA
		$V_{SS} \leq V_{IN} \leq V_{reg} R_X,$ Tx I/Os	-	-	50	
R_{PU}	Weak pull-up equivalent resistor ⁽⁵⁾	$V_{IN} = V_{SS}$	30	45	60	k Ω
$C_{IO}^{(6)}$	I/O pin capacitance		-	5	-	pF

- $V_{DD} = 3.0\text{ V}$, $T_A = -40$ to $85\text{ }^\circ\text{C}$ unless otherwise specified.
- Data based on characterization results, not tested in production.
- Hysteresis voltage between Schmitt trigger switching levels. Based on characterization results, not tested.
- The maximum value may be exceeded if negative current is injected on adjacent pins.
- R_{PU} pull-up equivalent resistor based on a resistive transistor (corresponding I_{PU} current characteristics).
- Data guaranteed by Design, not tested in production.

Figure 17. Typical pull-up resistance R_{PU} vs. V_{DD} with $V_{IN}=V_{SS}$

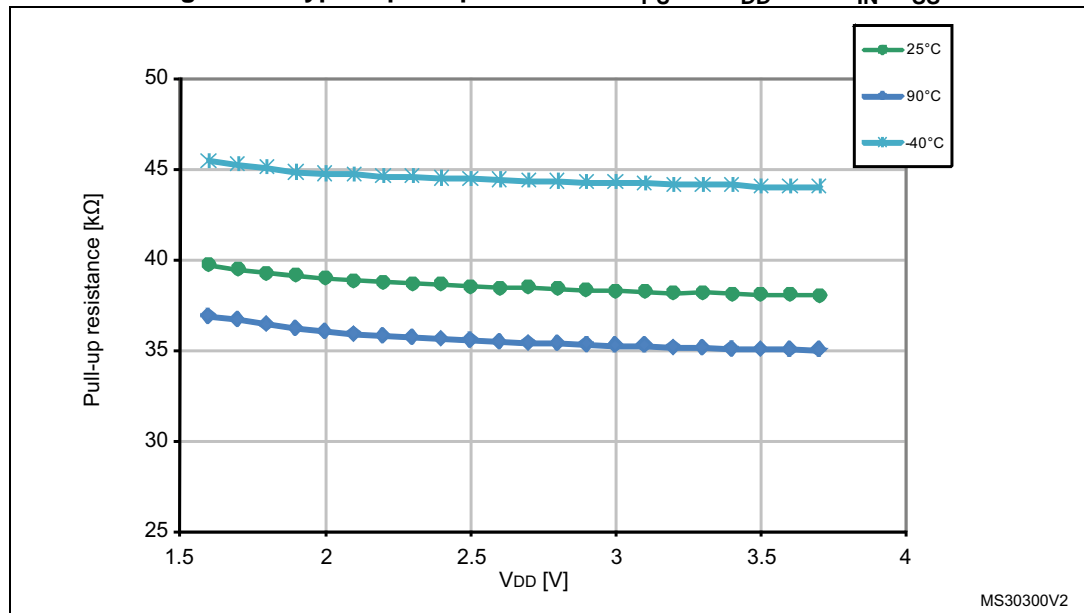
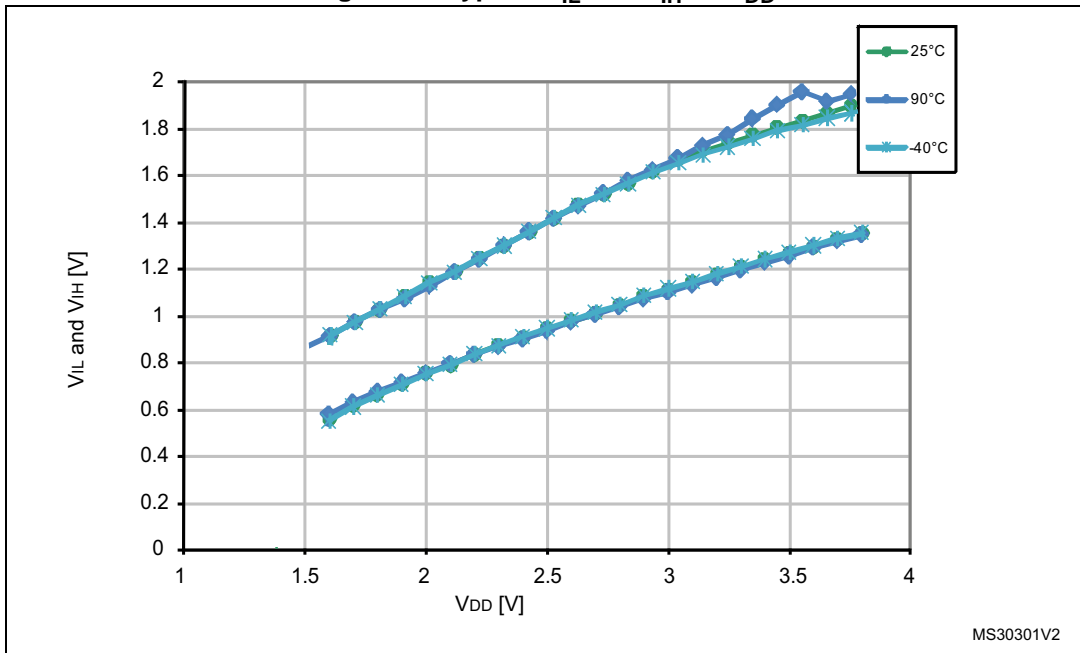

Figure 18. Typical V_{IL} and V_{IH} vs V_{DD}



Output driving current

Subject to general operating conditions for V_{DD} and T_A unless otherwise specified.

Table 32. Output driving current (high sink ports)

I/O type	Symbol	Parameter	Conditions	Min.	Max.	Unit
Standard	$V_{OL}^{(1)}$	Output low level voltage for an I/O pin	$I_{IO} = +2 \text{ mA}$, $V_{DD} = 1.8 \text{ V}$	-	0.45	V
			$I_{IO} = +2 \text{ mA}$, $V_{DD} = 3.0 \text{ V}$	-	0.45	
			$I_{IO} = +10 \text{ mA}$, $V_{DD} = 3.0 \text{ V}$	-	0.7	
	$V_{OH}^{(2)}$	Output high level voltage for an I/O pin	$I_{IO} = -1 \text{ mA}$, $V_{DD} = 1.8 \text{ V}$	$V_{DD}-0.45$	-	
			$I_{IO} = -1 \text{ mA}$, $V_{DD} = 3.0 \text{ V}$	$V_{DD}-0.45$	-	
			$I_{IO} = -10 \text{ mA}$, $V_{DD} = 3.0 \text{ V}$	$V_{DD}-0.7$	-	
ProxSense I/O	V_{OH}	Output high level voltage for PXS_TX ProxSense I/O	$I_{PXS_TX} = 0.2 \text{ mA}$	V_{REG}	-	
	V_{OH}	Output high level voltage for PXS_RX ProxSense I/O	$I_{PXS_RX} = 0.1 \text{ mA}$	V_{REG}	-	

1. The I_{IO} current sunk must always respect the absolute maximum rating and the sum of I_{IO} (I/O ports and control pins) must not exceed I_{VSS} .
2. The I_{IO} current sourced must always respect the absolute maximum rating and the sum of I_{IO} (I/O ports and control pins) must not exceed I_{VDD} .

Figure 19. Typ. V_{OL} at $V_{DD} = 1.8 \text{ V}$ (standard ports)

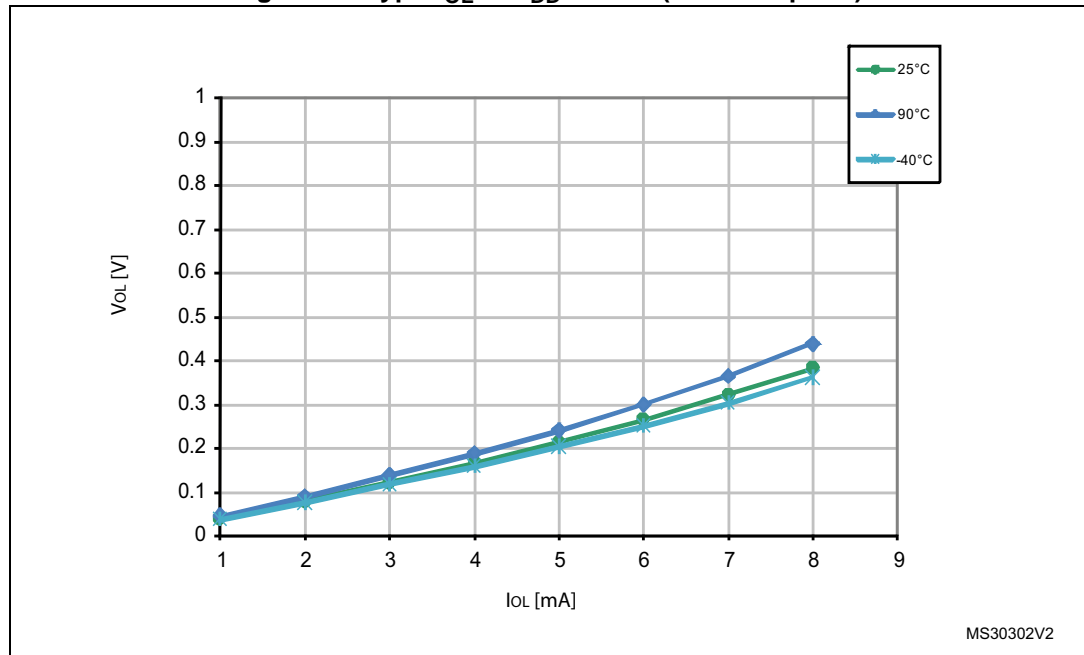

MS30302V2

Figure 20. Typ. V_{OL} at $V_{DD} = 3.0\text{ V}$ (standard ports)

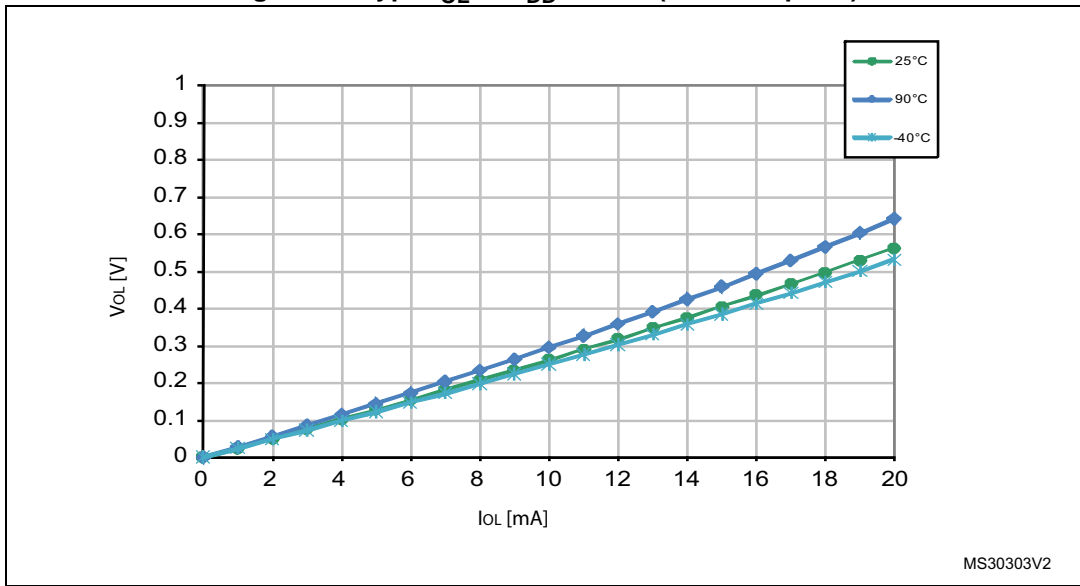

Figure 21. Typ. $V_{DD} - V_{OH}$ at $V_{DD} = 1.8\text{ V}$ (standard ports)

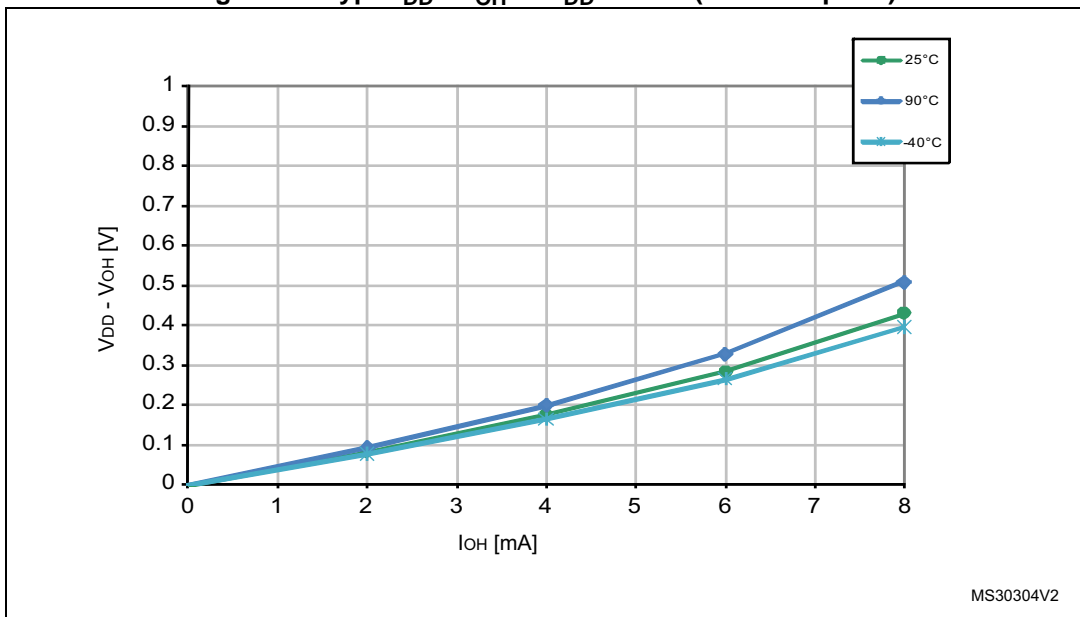

Figure 22. Typ. $V_{DD} - V_{OH}$ at $V_{DD} = 3.0\text{ V}$ (standard ports)

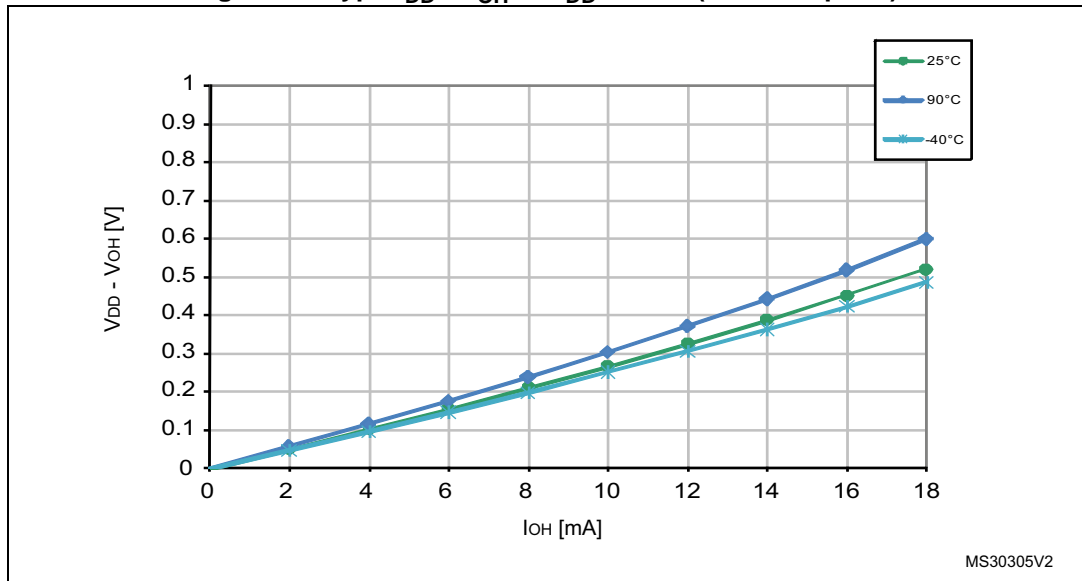

Figure 23. Typ. $V_{DD} - V_{OH}$ at $V_{DD} = 1.8\text{ V}$ (ProxSense_TX ports)

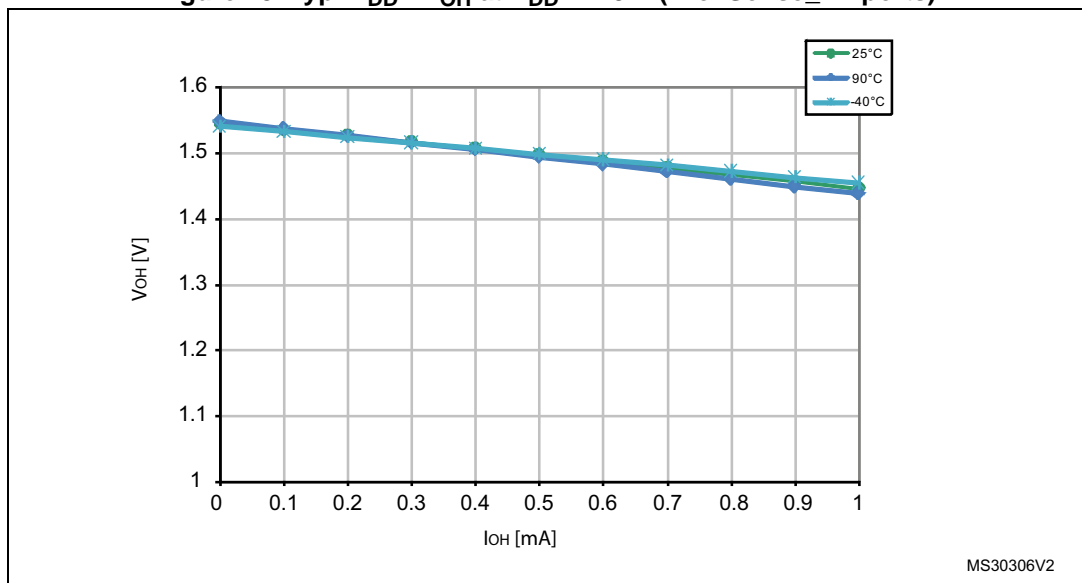
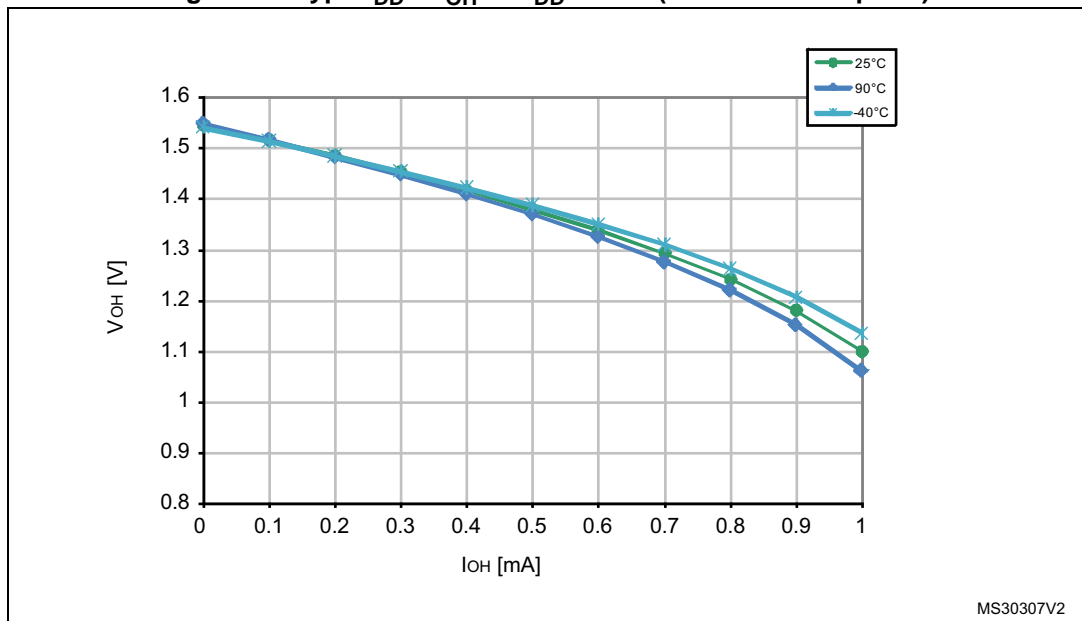

Figure 24. Typ. $V_{DD} - V_{OH}$ at $V_{DD} = 1.8V$ (ProxSense RX ports)



NRST pin

The NRST pin input driver is CMOS. A permanent pull-up is present which is the same as R_{PU} (see [Table 31 on page 56](#)).

Subject to general operating conditions for V_{DD} and T_A unless otherwise specified.

Table 33. NRST pin characteristics

Symbol	Parameter	Conditions	Min.	Typ. ⁽¹⁾	Max.	Unit
$V_{IL(NRST)}$	NRST input low level voltage ⁽¹⁾	-	V_{SS}	-	0.8	V
$V_{IH(NRST)}$	NRST input high level voltage ⁽¹⁾	-	1.4	-	V_{DD}	
$V_{OL(NRST)}$	NRST output low level voltage	$I_{OL} = 2 \text{ mA}$	-	-	$V_{DD} - 0.8$	
$R_{PU(NRST)}$	NRST pull-up equivalent resistor ⁽²⁾	-	30	45	60	k Ω
$V_{F(NRST)}$	NRST input filtered pulse ⁽³⁾	-	-	-	50	ns
$t_{OP(NRST)}$	NRST output pulse width	-	20	-	-	
$V_{NF(NRST)}$	NRST input not filtered pulse ⁽³⁾	-	300	-	-	

1. Data based on characterization results, not tested in production.
2. The R_{PU} pull-up equivalent resistor is based on a resistive transistor.
3. Data guaranteed by design, not tested in production.

The reset network shown in [Figure 26](#) protects the device against parasitic resets. The user must ensure that the level on the NRST pin can go below the V_{IL} max. level specified in [Table 33](#). Otherwise the reset is not taken into account internally.

Figure 25. Typical NRST pull-up resistance R_{PU} vs. V_{DD}

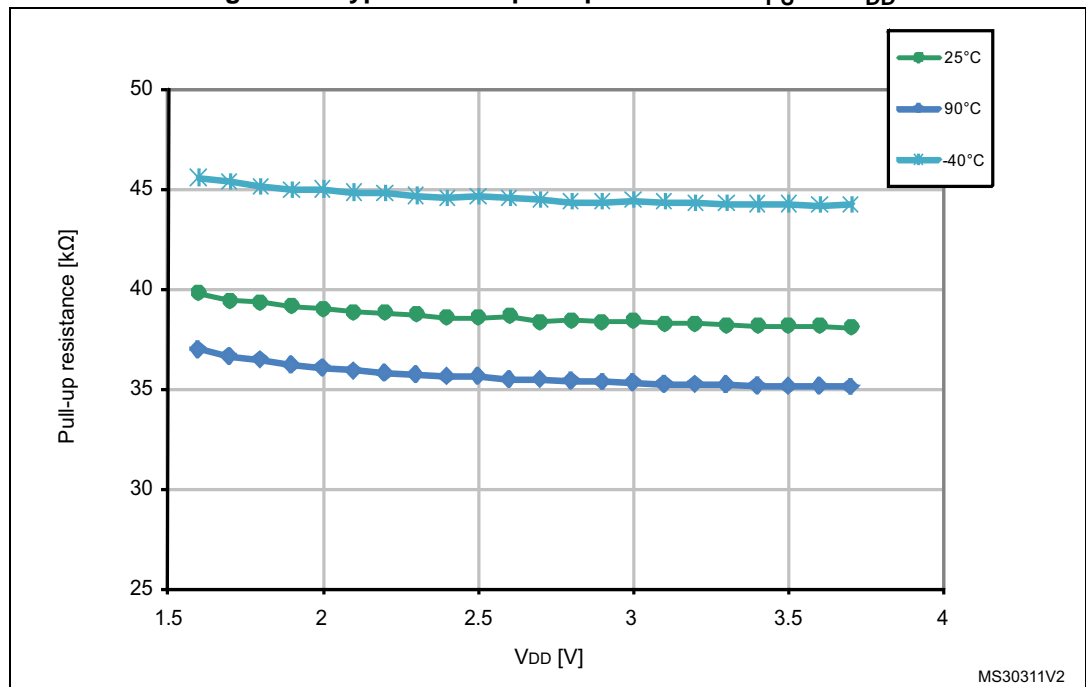
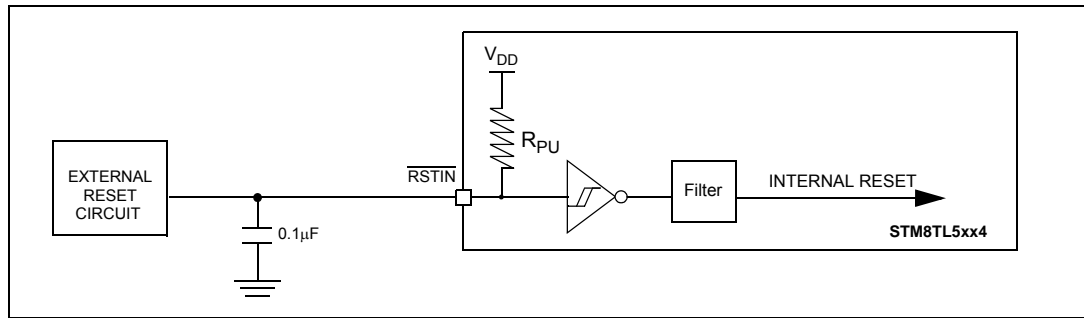

Figure 26. Recommended NRST pin configuration



The reset network shown in [Figure 26](#) protects the device against parasitic resets. The user must ensure that the level on the NRST pin can go below the V_{IL} max. level specified in [Table 33](#). Otherwise the reset is not taken into account internally.

For power consumption sensitive applications, the capacity of the external reset capacitor can be reduced to limit the charge/discharge current. If the NRST signal is used to reset the external circuitry, the user must pay attention to the charge/discharge time of the external capacitor to meet the reset timing conditions of the external devices. The minimum recommended capacity is 10 nF.

9.3.9 Communication interfaces

Serial peripheral interface (SPI)

The parameters given in [Table 34](#) are derived from tests performed under ambient temperature, f_{MASTER} frequency and V_{DD} supply voltage conditions summarized in [Section 9.3.1 on page 45](#), unless otherwise specified. Refer to I/O port characteristics for more details on the input/output alternate function characteristics (NSS, SCK, MOSI, MISO).

Table 34. SPI characteristics

Symbol	Parameter	Conditions ⁽¹⁾	Min.	Max.	Unit
f_{SCK} $1/t_{\text{c(SCK)}}$	SPI clock frequency	Master mode	0	8	MHz
		Slave mode	0	8	
$t_{\text{r(SCK)}}$ $t_{\text{f(SCK)}}$	SPI clock rise and fall time	Capacitive load: C = 30 pF	-	30	ns
$t_{\text{su(NSS)}}^{(2)}$	NSS setup time	Slave mode	$4 \times t_{\text{MASTER}}$	-	
$t_{\text{h(NSS)}}^{(2)}$	NSS hold time	Slave mode	80	-	
$t_{\text{w(SCKH)}}^{(2)}$ $t_{\text{w(SCKL)}}^{(2)}$	SCK high and low time	Master mode, $f_{\text{MASTER}} = 8 \text{ MHz}, f_{\text{SCK}} = 4 \text{ MHz}$	105	145	
$t_{\text{su(MI)}}^{(2)}$ $t_{\text{su(SI)}}^{(2)}$	Data input setup time	Master mode	30	-	
		Slave mode	3	-	
$t_{\text{h(MI)}}^{(2)}$ $t_{\text{h(SI)}}^{(2)}$	Data input hold time	Master mode	15	-	
		Slave mode	0	-	
$t_{\text{a(SO)}}^{(2)(3)}$	Data output access time	Slave mode	-	$3 \times t_{\text{MASTER}}$	
$t_{\text{dis(SO)}}^{(2)(4)}$	Data output disable time	Slave mode	30	-	
$t_{\text{v(SO)}}^{(2)}$	Data output valid time	Slave mode (after enable edge)	-	60	
$t_{\text{v(MO)}}^{(2)}$	Data output valid time	Master mode (after enable edge)	-	20	
$t_{\text{h(SO)}}^{(2)}$ $t_{\text{h(MO)}}^{(2)}$	Data output hold time	Slave mode (after enable edge)	15	-	
		Master mode (after enable edge)	1	-	

- Parameters are given by selecting 10-MHz I/O output frequency.
- Values based on design simulation and/or characterization results, and not tested in production.
- Min time is for the minimum time to drive the output and max time is for the maximum time to validate the data.
- Min time is for the minimum time to invalidate the output and max time is for the maximum time to put the data in Hi-Z.

Figure 27. SPI timing diagram - slave mode and CPHA = 0

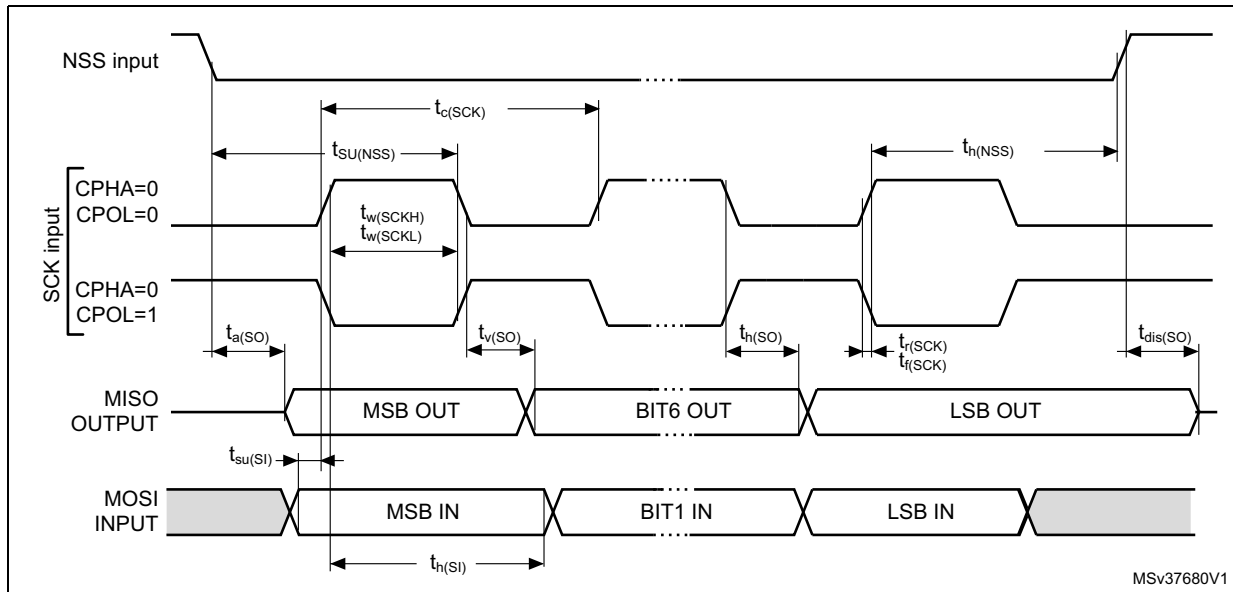

MSv37680V1

Figure 28. SPI timing diagram - slave mode and CPHA = 1⁽¹⁾

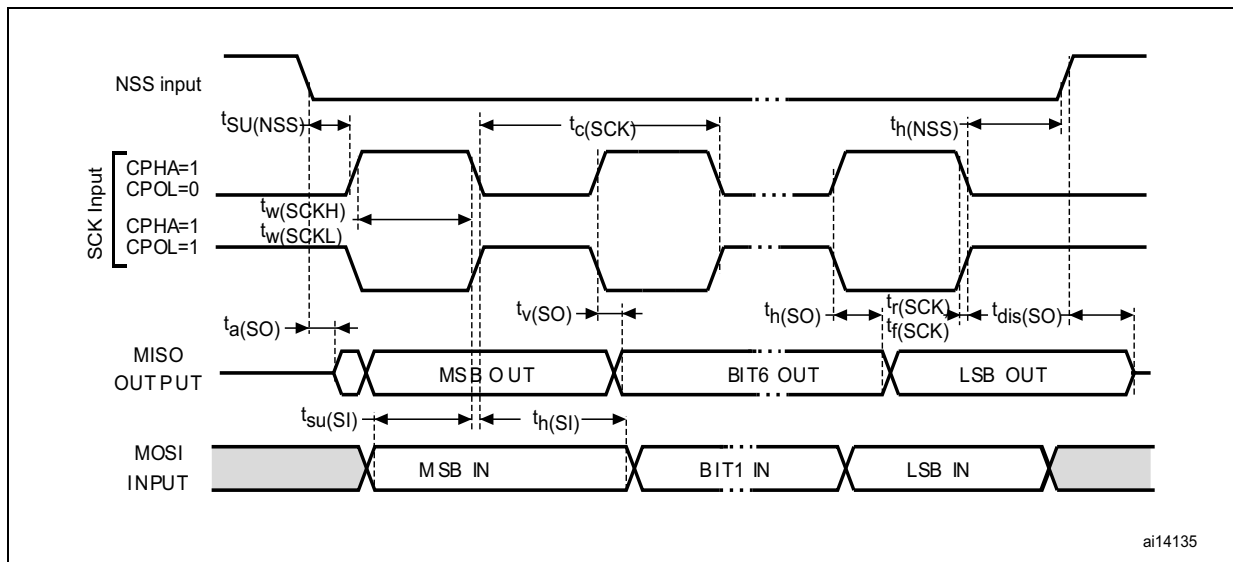

ai14135

1. Measurement points are done at CMOS levels: 0.3 V_{DD} and 0.7 V_{DD} .

Figure 29. SPI timing diagram - master mode⁽¹⁾

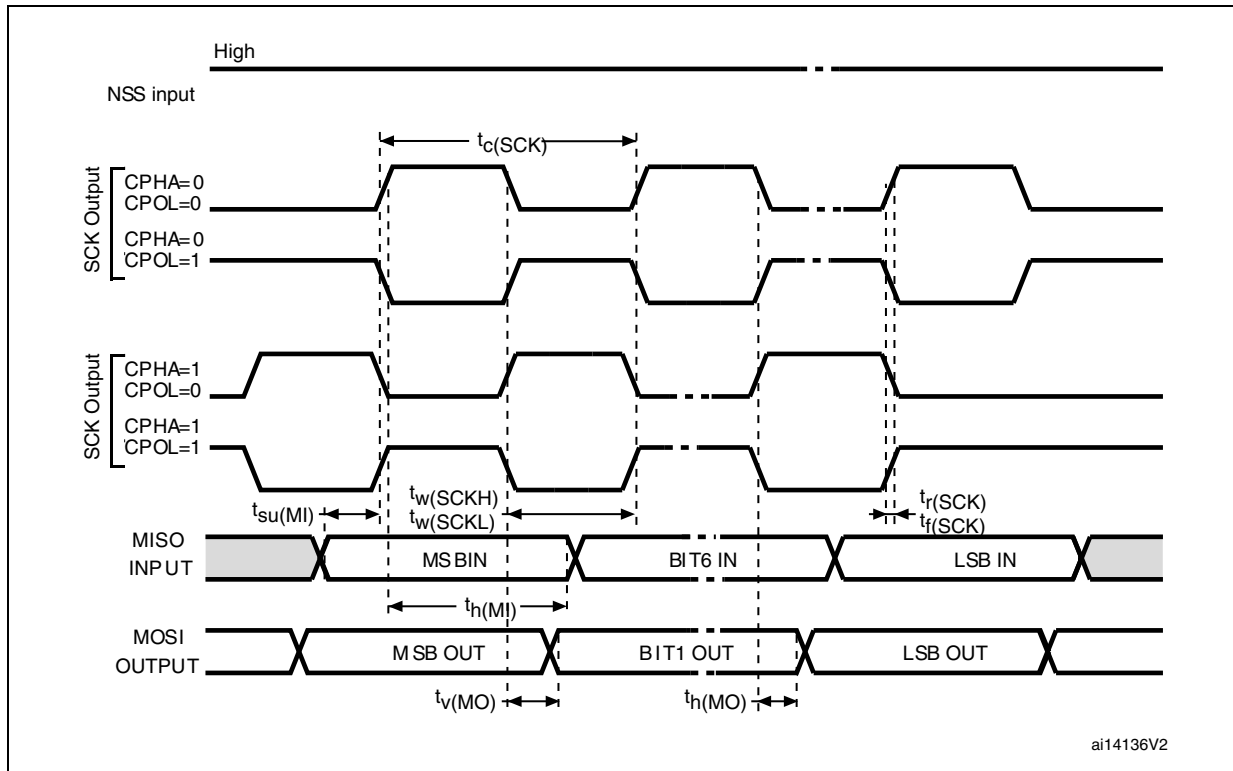

1. Measurement points are done at CMOS levels: $0.3 V_{DD}$ and $0.7 V_{DD}$.

Inter IC control interface (I2C)

Subject to general operating conditions for V_{DD} , f_{MASTER} , and T_A unless otherwise specified.

The STM8TL5xx4 I2C interface meets the requirements of the Standard I2C communication protocol described in the following table with the restrictions mentioned below.

Refer to I/O port characteristics for more details on the input/output alternate function characteristics (SDA and SCL).

Table 35. I²C characteristics

Symbol	Parameter	Standard mode I ² C		Fast mode I ² C ⁽¹⁾		Unit
		Min ⁽²⁾	Max ⁽²⁾	Min ⁽²⁾	Max ⁽²⁾	
$t_{w(SCLL)}$	SCL clock low time	4.7	-	1.3	-	μs
$t_{w(SCLH)}$	SCL clock high time	4.0	-	0.6	-	
$t_{su(SDA)}$	SDA setup time	250	-	100	-	ns
$t_{h(SDA)}$	SDA data hold time	0 ⁽³⁾	-	0 ⁽⁴⁾	900 ⁽³⁾	
$t_{r(SDA)}$ $t_{r(SCL)}$	SDA and SCL rise time	-	1000	-	300	
$t_{f(SDA)}$ $t_{f(SCL)}$	SDA and SCL fall time	-	300	-	300	
$t_{h(STA)}$	START condition hold time	4.0	-	0.6	-	μs
$t_{su(STA)}$	Repeated START condition setup time	4.7	-	0.6	-	
$t_{su(STO)}$	STOP condition setup time	4.0	-	0.6	-	μs
$t_{w(STO:STA)}$	STOP to START condition time (bus free)	4.7	-	1.3	-	μs
C_b	Capacitive load for each bus line	-	400	-	400	pF

1. f_{SCK} must be at least 8 MHz to achieve max fast I²C speed (400 kHz).
2. Data based on standard I²C protocol requirement, not tested in production.
3. The maximum hold time of the START condition has only to be met if the interface does not stretch the low period of SCL signal.
4. The device must internally provide a hold time of at least 300 ns for the SDA signal in order to bridge the undefined region of the falling edge of SCL).

Note: For speeds around 200 kHz, achieved speed can have $\pm 5\%$ tolerance.
For other speed ranges, achieved speed can have $\pm 2\%$ tolerance.
The above variations depend on the accuracy of the external components used.

Figure 30. Typical application with I²C bus and timing diagram ¹⁾

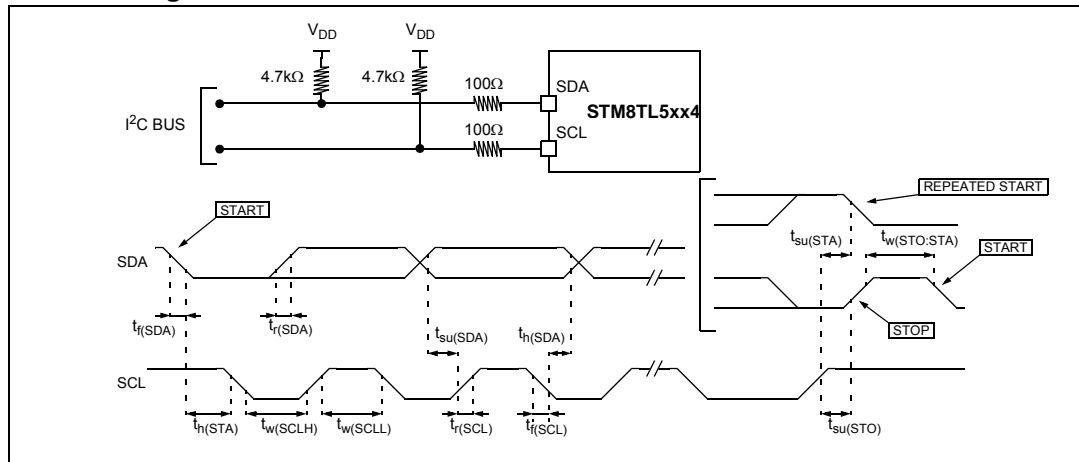

1. Measurement points are done at CMOS levels: $0.3 \times V_{DD}$ and $0.7 \times V_{DD}$.

9.3.10 EMC characteristics

Susceptibility tests are performed on a sample 36 basis during product characterization.

Functional EMS (electromagnetic susceptibility)

Based on a simple running application on the product (toggling 2 LEDs through I/O ports), the product is stressed by two electromagnetic events until a failure occurs (indicated by the LEDs).

- **ESD:** Electrostatic discharge (positive and negative) is applied on all pins of the device until a functional disturbance occurs. This test conforms with the IEC 61000-4-2 standard.
- **FTB:** A burst of fast transient voltage (positive and negative) is applied to V_{DD} and V_{SS} through a 100 pF capacitor, until a functional disturbance occurs. This test conforms with the IEC 61000-4-4 standard.

A device reset allows normal operations to be resumed. The test results are given in the table below based on the EMS levels and classes defined in application note AN1709.

Designing hardened software to avoid noise problems

EMC characterization and optimization are performed at component level with a typical application environment and simplified MCU software. It should be noted that good EMC performance is highly dependent on the user application and the software in particular.

Therefore it is recommended that the user applies EMC software optimization and prequalification tests in relation with the EMC level requested for his application.

Prequalification trials:

Most of the common failures (unexpected reset and program counter corruption) can be reproduced by manually forcing a low state on the NRST pin or the oscillator pins for 1 second.

To complete these trials, ESD stress can be applied directly on the device, over the range of specification values. When unexpected behavior is detected, the software can be hardened to prevent unrecoverable errors occurring (see application note AN1015).

Table 36. EMS data

Symbol	Parameter	Conditions	Level/Class
V _{FESD}	Voltage limits to be applied on any I/O pin to induce a functional disturbance	UFQFPN48, V _{DD} = 3.3 V	3B
V _{EFTB}	Fast transient voltage burst limits to be applied through 100 pF on V _{DD} and V _{SS} pins to induce a functional disturbance	UFQFPN48, V _{DD} = 3.3 V, f _{HSI}	3B

Electromagnetic interference (EMI)

Based on a simple application running on the product (toggling 2 LEDs through the I/O ports), the product is monitored in terms of emission. This emission test is in line with the norm SAE J 1752/3 which specifies the board and the loading of each pin.

Table 37. EMI data ⁽¹⁾

Symbol	Parameter	Conditions	Monitored frequency band	Max vs. 16 MHz	Unit
S _{EMI}	Peak level	V _{DD} = 3.6 V, T _A = +25 °C	0.1 MHz to 30 MHz	-5	dB μ V
			30 MHz to 130 MHz	-5	
			130 MHz to 1 GHz	0	
			SAE EMI Level	1	-

1. Not tested in production.

Absolute maximum ratings (electrical sensitivity)

Based on two different tests (ESD and LU) using specific measurement methods, the product is stressed in order to determine its performance in terms of electrical sensitivity. For more details, refer to application note AN1181.

Electrostatic discharge (ESD)

Electrostatic discharges (a positive then a negative pulse separated by 1 second) are applied to the pins of each sample according to each pin combination. The sample size depends on the number of supply pins in the device (3 parts*(n+1) supply pin). Two models can be simulated: human body model and charge device model. This test conforms to the JESD22-A114A/A115A standard.

Table 38. ESD absolute maximum ratings

Symbol	Ratings	Conditions	Maximum value ⁽¹⁾	Unit
V _{ESD(HBM)}	Electrostatic discharge voltage (human body model)	T _A = +25 °C	2000 ⁽²⁾	V
V _{ESD(CDM)}	Electrostatic discharge voltage (charge device model)		1000	

1. Data based on characterization results, not tested in production.

2. Device sustained up to 3000 V during ESD trials.

Static latch-up

- **LU:** 3 complementary static tests are required on 6 parts to assess the latch-up performance. A supply overvoltage (applied to each power supply pin) and a current injection (applied to each input, output and configurable I/O pin) are performed on each sample. This test conforms to the EIA/JESD 78 IC latch-up standard. For more details, refer to application note AN1181.

Table 39. Electrical sensitivities

Symbol	Parameter	Class
LU	Static latch-up class	II

9.4 Thermal characteristics

The maximum chip junction temperature (T_{Jmax}) must never exceed the values given in [Table 16: General operating conditions on page 45](#).

The maximum chip-junction temperature, T_{Jmax} , in degrees Celsius, may be calculated using the following equation:

$$T_{Jmax} = T_{Amax} + (P_{Dmax} \times \Theta_{JA})$$

Where:

- T_{Amax} is the maximum ambient temperature in °C
- Θ_{JA} is the package junction-to-ambient thermal resistance in °C/W
- P_{Dmax} is the sum of P_{INTmax} and $P_{I/Omax}$ ($P_{Dmax} = P_{INTmax} + P_{I/Omax}$)
- P_{INTmax} is the product of I_{DD} and V_{DD} , expressed in watts. This is the maximum chip internal power.
- $P_{I/Omax}$ represents the maximum power dissipation on output pins where:
 $P_{I/Omax} = \Sigma (V_{OL} * I_{OL}) + \Sigma ((V_{DD} - V_{OH}) * I_{OH})$,
 taking into account the actual V_{OL}/I_{OL} and V_{OH}/I_{OH} of the I/Os at low and high level in the application.

Table 40. Thermal characteristics⁽¹⁾

Symbol	Parameter	Value	Unit
Θ_{JA}	Thermal resistance junction-ambient UFQFPN 48 - 7 x 7 mm	32	°C/W
	Thermal resistance junction-ambient UFQFPN 28 - 4 x 4 mm	80	
	Thermal resistance junction-ambient TSSOP20	110	

1. Thermal resistances are based on JEDEC JESD51-2 with 4-layer PCB in a natural convection environment.



10 Package information

10.1 ECOPACK®

In order to meet environmental requirements, ST offers these devices in different grades of ECOPACK® packages, depending on their level of environmental compliance. ECOPACK® specifications, grade definitions and product status are available at: www.st.com. ECOPACK® is an ST trademark.

10.2 UFQFPN48 package information

Figure 31. UFQFPN48 - 48-lead, 7x7 mm, 0.5 mm pitch, ultra thin fine pitch quad flat package outline

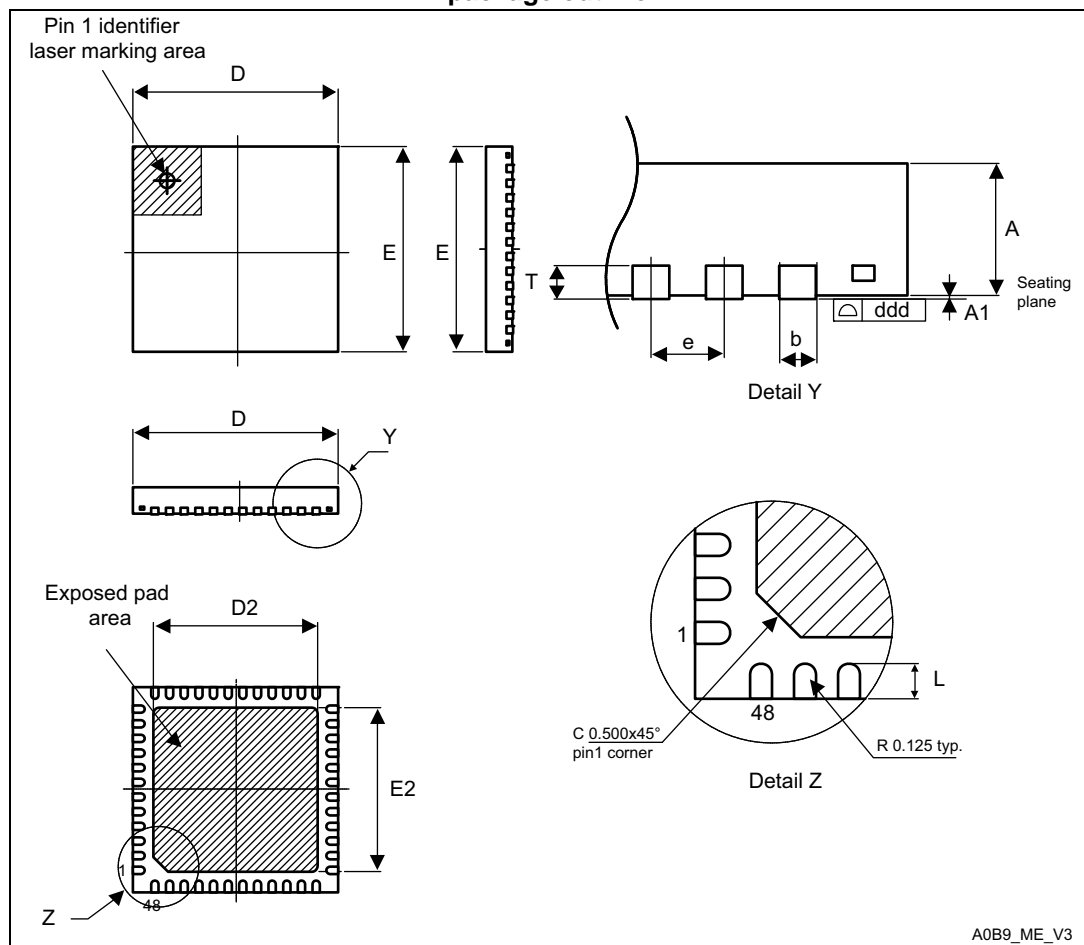

1. Drawing is not to scale.
2. All leads/pads should also be soldered to the PCB to improve the lead/pad solder joint life.
3. There is an exposed die pad on the underside of the UFQFPN package. It is recommended to connect and solder this back-side pad to PCB ground.

Table 41. UFQFPN48 - 48-lead, 7x7 mm, 0.5 mm pitch, ultra thin fine pitch quad flat package mechanical data

Symbol	millimeters			inches ⁽¹⁾		
	Min	Typ	Max	Min	Typ	Max
A	0.500	0.550	0.600	0.0197	0.0217	0.0236
A1	0.000	0.020	0.050	0.0000	0.0008	0.0020
D	6.900	7.000	7.100	0.2717	0.2756	0.2795
E	6.900	7.000	7.100	0.2717	0.2756	0.2795
D2	5.500	5.600	5.700	0.2165	0.2205	0.2244
E2	5.500	5.600	5.700	0.2165	0.2205	0.2244
L	0.300	0.400	0.500	0.0118	0.0157	0.0197
T	-	0.152	-	-	0.0060	-
b	0.200	0.250	0.300	0.0079	0.0098	0.0118
e	-	0.500	-	-	0.0197	-
ddd	-	-	0.080	-	-	0.0031

1. Values in inches are converted from mm and rounded to 4 decimal digits.

Figure 32. UFQFPN48 - 48-lead, 7x7 mm, 0.5 mm pitch, ultra thin fine pitch quad flat package recommended footprint

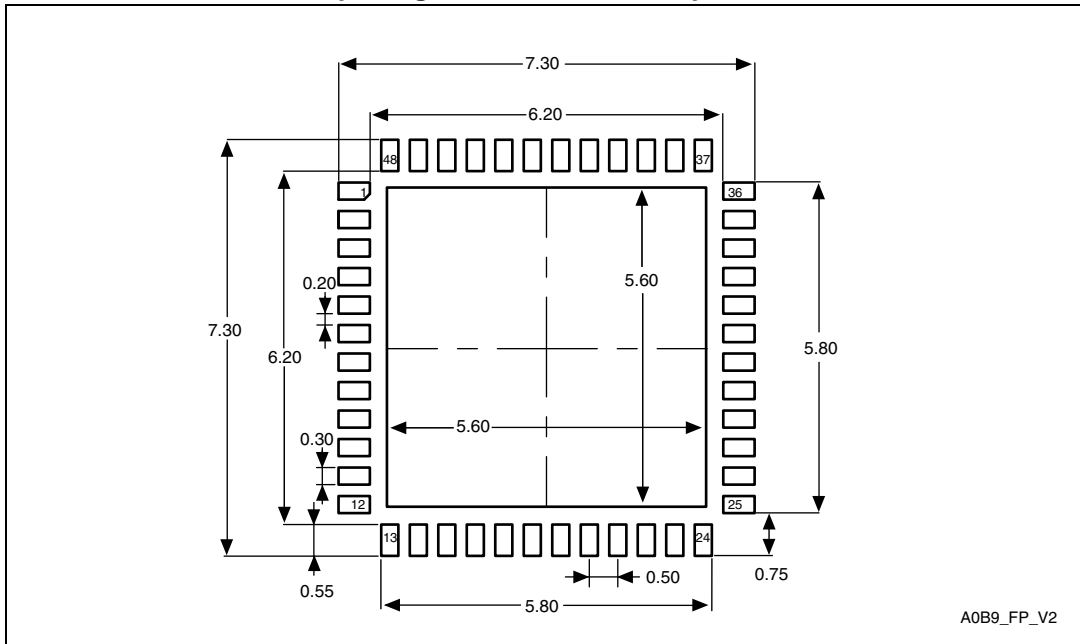

1. Dimensions are expressed in millimeters.

Device marking

The following figure gives an example of topside marking orientation versus pin 1 identifier location.

Figure 33. UFQFPN48 marking example (package top view)

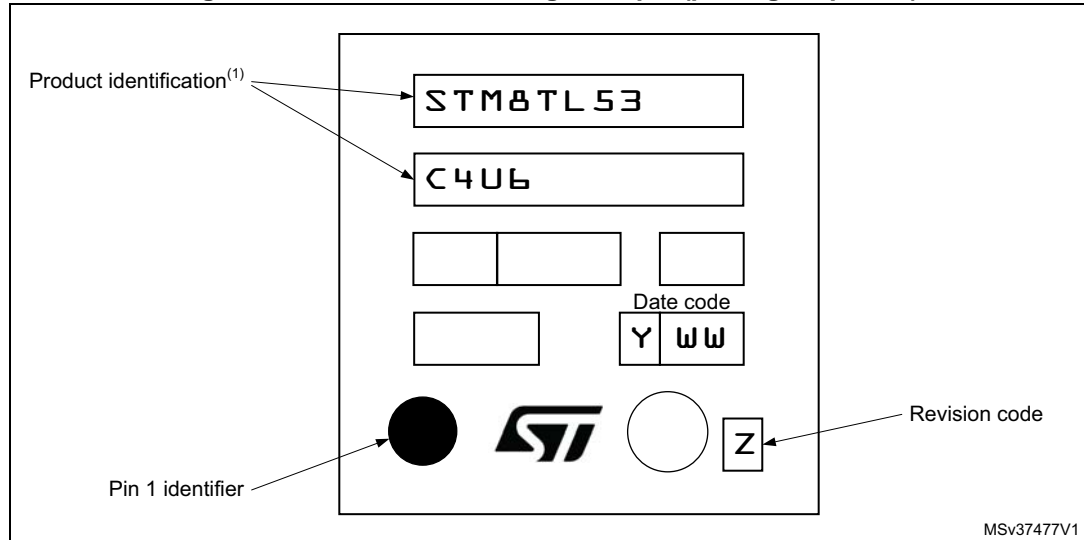

1. Parts marked as "ES", "E" or accompanied by an Engineering Sample notification letter, are not yet qualified and therefore not yet ready to be used in production and any consequences deriving from such usage will not be at ST charge. In no event, ST will be liable for any customer usage of these engineering samples in production. ST Quality has to be contacted prior to any decision to use these Engineering samples to run qualification activity.

10.3 UFQFPN28 package information

Figure 34. UFQFPN28 - 28-lead, 7x7 mm, 0.5 mm pitch, ultra thin fine pitch quad flat package outline

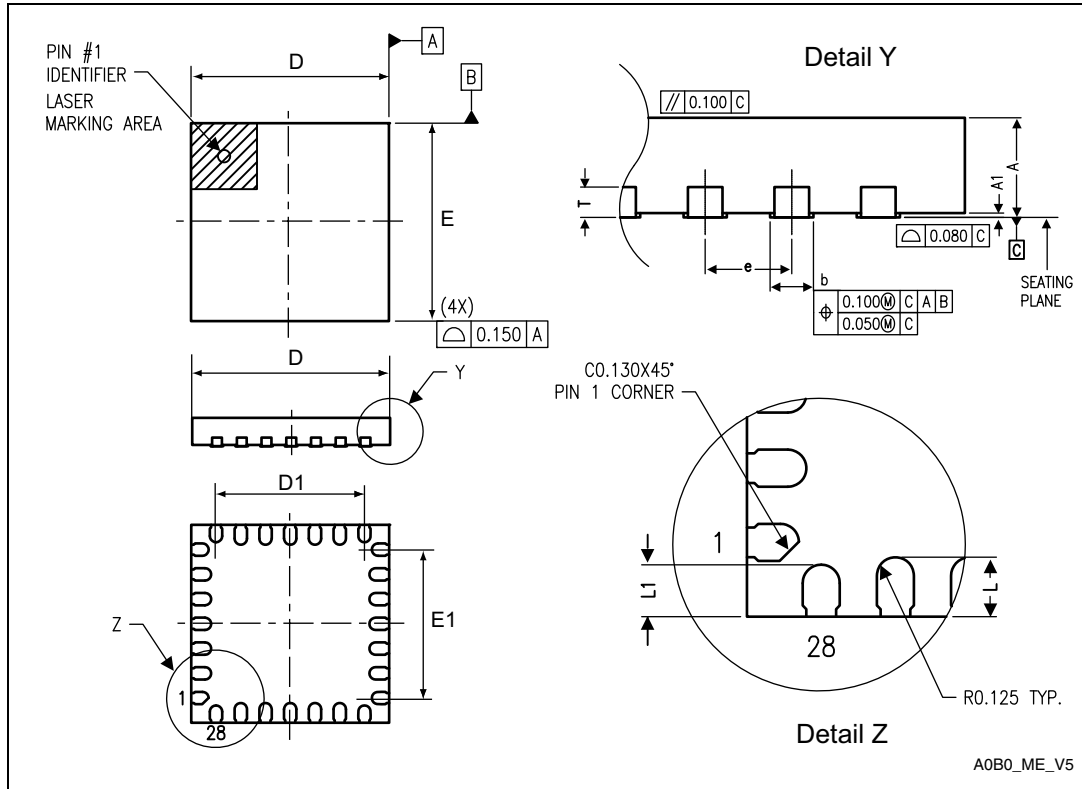

1. Drawing is not to scale.

Table 42. UFQFPN28 - 28-lead, 7x7 mm, 0.5 mm pitch, ultra thin fine pitch quad flat package mechanical data⁽¹⁾

Symbol	millimeters			inches		
	Min	Typ	Max	Min	Typ	Max
A	0.500	0.550	0.600	0.0197	0.0217	0.0236
A1	-	0.000	0.050	-	0.0000	0.0020
D	3.900	4.000	4.100	0.1535	0.1575	0.1614
D1	2.900	3.000	3.100	0.1142	0.1181	0.1220
E	3.900	4.000	4.100	0.1535	0.1575	0.1614
E1	2.900	3.000	3.100	0.1142	0.1181	0.1220
L	0.300	0.400	0.500	0.0118	0.0157	0.0197
L1	0.250	0.350	0.450	0.0098	0.0138	0.0177
T	-	0.152	-	-	0.0060	-
b	0.200	0.250	0.300	0.0079	0.0098	0.0118
e	-	0.500	-	-	0.0197	-

1. Values in inches are converted from mm and rounded to 4 decimal digits.

Figure 35. UFQFPN28 - 28-lead, 7x7 mm, 0.5 mm pitch, ultra thin fine pitch quad flat package recommended footprint

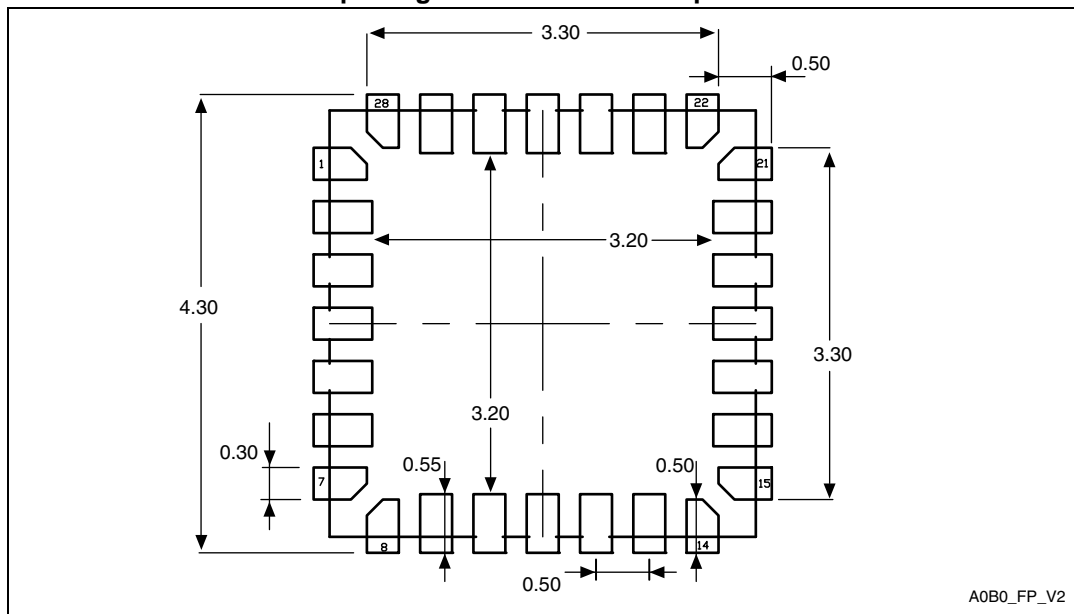

1. Dimensions are expressed in millimeters.

Device marking

The following figure gives an example of topside marking orientation versus pin 1 identifier location.

Figure 36. UFQFPN28 marking example (package top view)

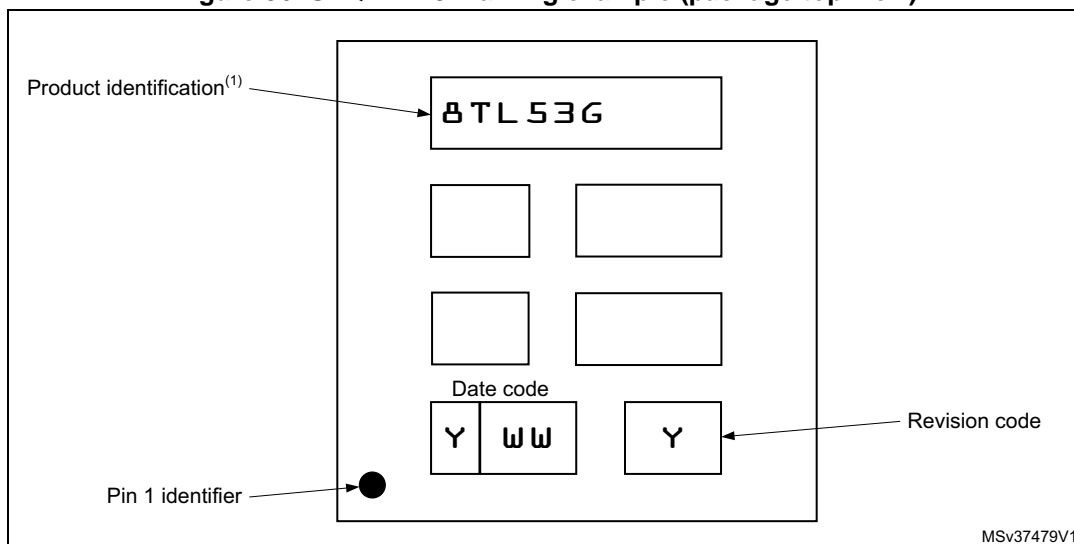

1. Parts marked as "ES", "E" or accompanied by an Engineering Sample notification letter, are not yet qualified and therefore not yet ready to be used in production and any consequences deriving from such usage will not be at ST charge. In no event, ST will be liable for any customer usage of these engineering

samples in production. ST Quality has to be contacted prior to any decision to use these Engineering samples to run qualification activity.

10.4 TSSOP20 package information

Figure 37. TSSOP20 – 20-lead thin shrink small outline, 6.5 x 4.4 mm, 0.65 mm pitch, package outline

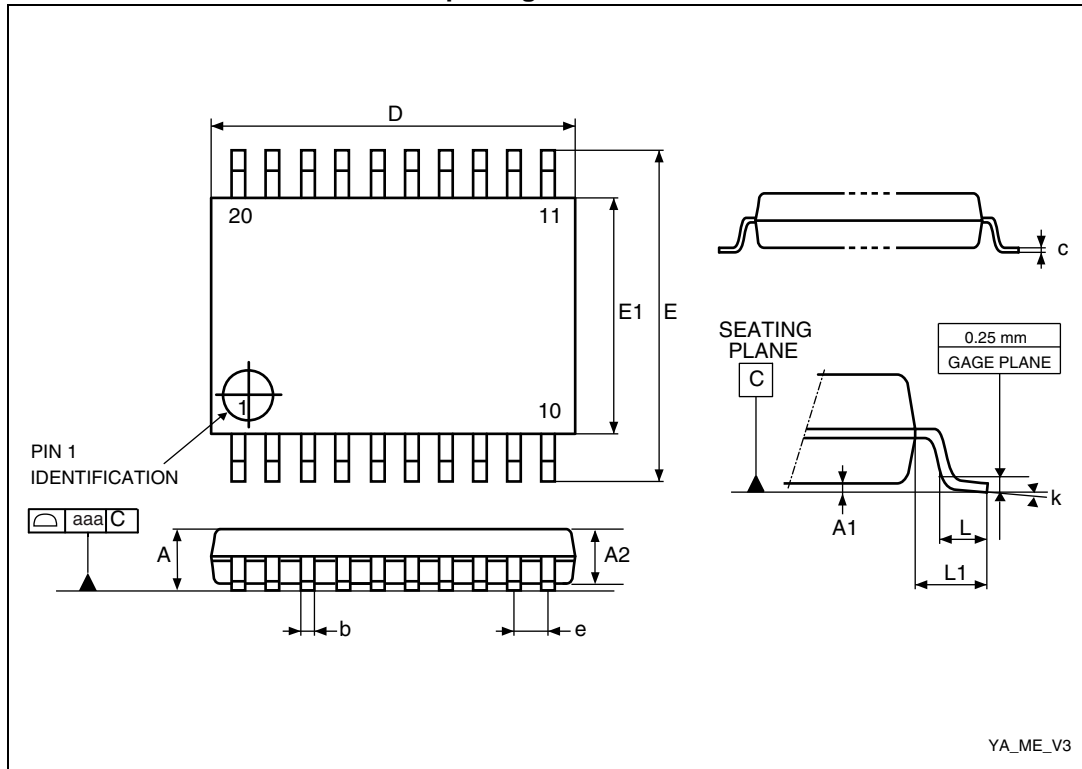

1. Drawing is not to scale.

Table 43. TSSOP20 – 20-lead thin shrink small outline, 6.5 x 4.4 mm, 0.65 mm pitch, package mechanical data

Symbol	millimeters			inches ⁽¹⁾		
	Min.	Typ.	Max.	Min.	Typ.	Max.
A	-	-	1.200	-	-	0.0472
A1	0.050	-	0.150	0.0020	-	0.0059
A2	0.800	1.000	1.050	0.0315	0.0394	0.0413
b	0.190	-	0.300	0.0075	-	0.0118
c	0.090	-	0.200	0.0035	-	0.0079
D	6.400	6.500	6.600	0.2520	0.2559	0.2598
E	6.200	6.400	6.600	0.2441	0.2520	0.2598
E1	4.300	4.400	4.500	0.1693	0.1732	0.1772
e	-	0.650	-	-	0.0256	-

Table 43. TSSOP20 – 20-lead thin shrink small outline, 6.5 x 4.4 mm, 0.65 mm pitch, package mechanical data (continued)

Symbol	millimeters			inches ⁽¹⁾		
	Min.	Typ.	Max.	Min.	Typ.	Max.
L	0.450	0.600	0.750	0.0177	0.0236	0.0295
L1	-	1.000	-	-	0.0394	-
k	0°	-	8°	0°	-	8°
aaa	-	-	0.100	-	-	0.0039

1. Values in inches are converted from mm and rounded to four decimal digits.

Figure 38. TSSOP20 – 20-lead thin shrink small outline, 6.5 x 4.4 mm, 0.65 mm pitch, package footprint

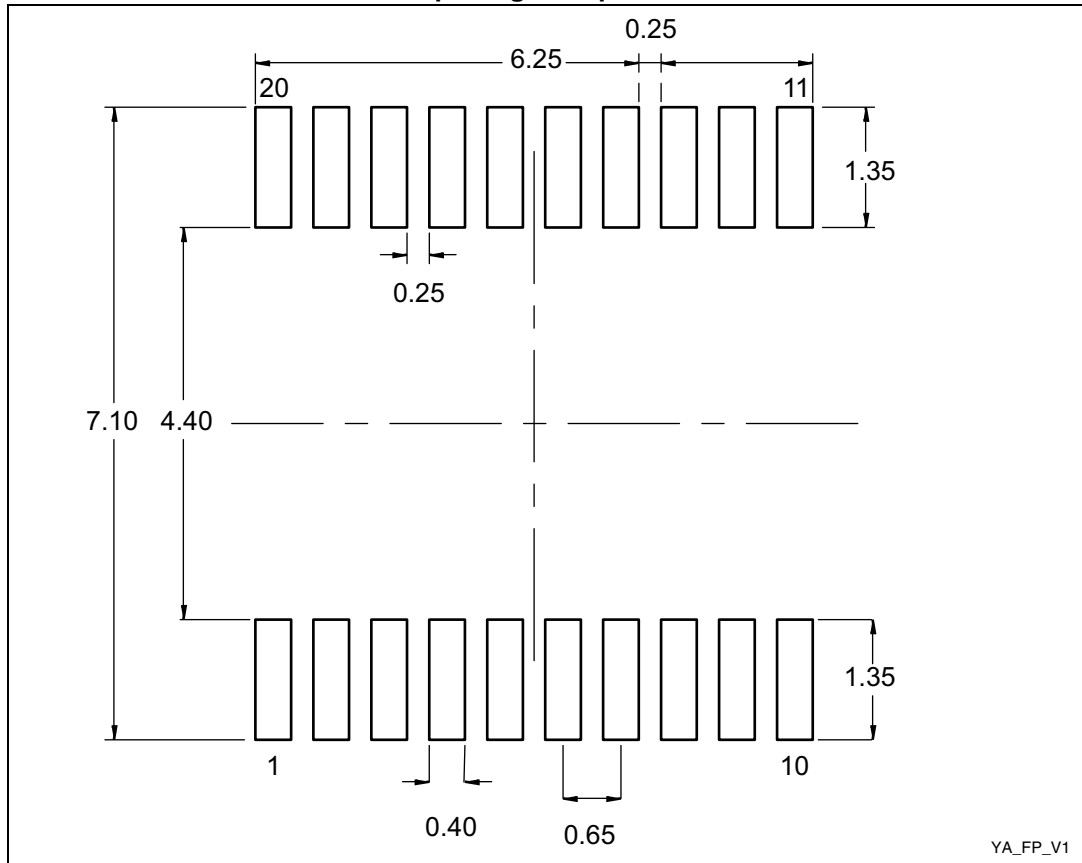

1. Dimensions are expressed in millimeters.

Device marking

The following figure gives an example of topside marking orientation versus pin 1 identifier location.

Figure 39. TSSOP20 marking example (package top view)

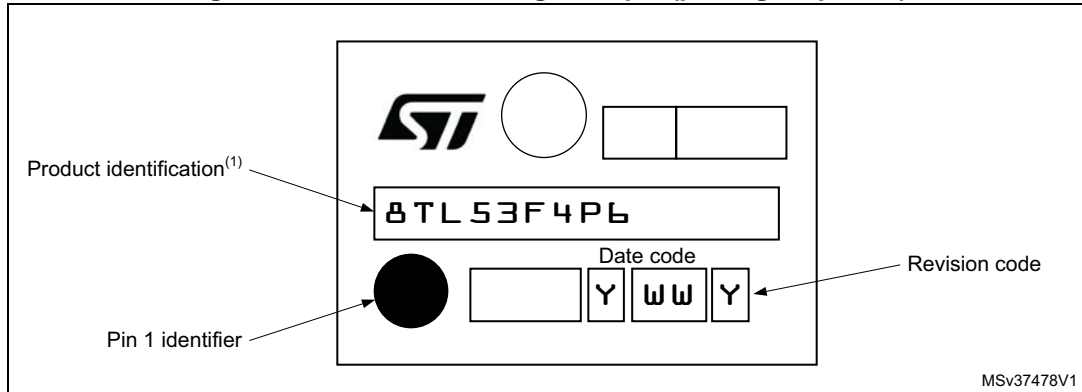

1. Parts marked as "ES", "E" or accompanied by an Engineering Sample notification letter, are not yet qualified and therefore not yet ready to be used in production and any consequences deriving from such usage will not be at ST charge. In no event, ST will be liable for any customer usage of these engineering samples in production. ST Quality has to be contacted prior to any decision to use these Engineering samples to run qualification activity.

11 Part numbering

Table 44. Ordering information scheme

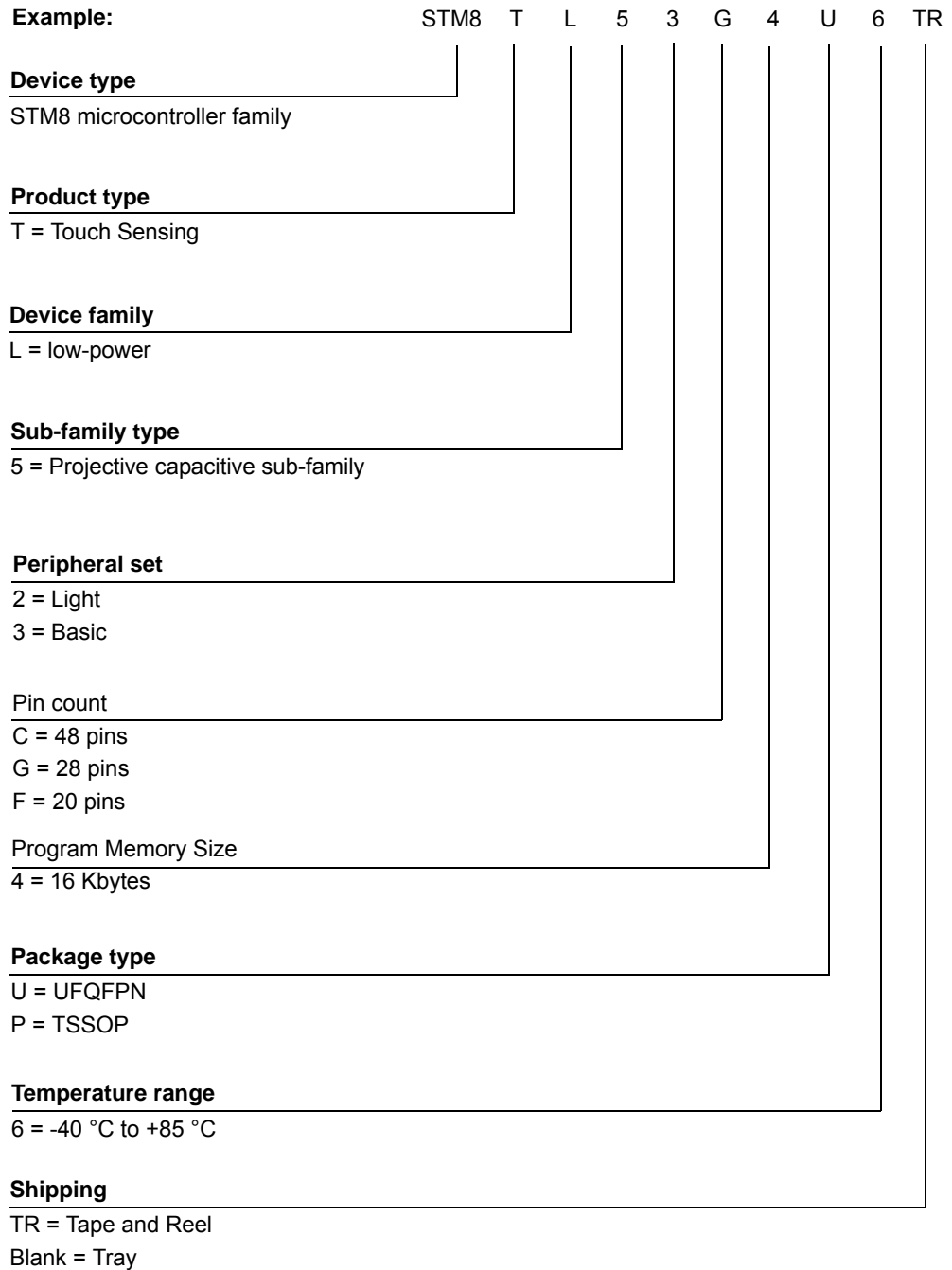

1. For a list of available options (e.g. memory size, package) and orderable part numbers or for further information on any aspect of this device, please go to www.st.com or contact the ST Sales Office nearest to you.

12 STM8 development tools

Development tools for the STM8 microcontrollers include the very low-cost debugger and programmer tool ST-Link supported by a complete software tool package including C compiler, assembler and integrated development environment with high-level language debugger. In addition, the STM8 is to be supported by a complete range of tools including starter kits, evaluation boards and a low-cost in-circuit debugger/programmer.

12.1 Software tools

STM8 development tools are supported by a complete, free software package from STMicroelectronics that includes ST Visual Develop (STVD) IDE and the ST Visual Programmer (STVP) software interface. STVD provides seamless integration of the Cosmic and Raisonance C compilers for STM8. A free version that outputs up to 32 Kbytes of code is available.

12.1.1 STM8 toolset

STM8 toolset with STVD integrated development environment and STVP programming software is available for free download at www.st.com. This package includes:

ST Visual Develop (STVD) – Full-featured integrated development environment from ST, featuring

- Seamless integration of C and ASM toolsets
- Full-featured debugger
- Project management
- Syntax highlighting editor
- Integrated programming interface

ST Visual Programmer (STVP) – Easy-to-use, unlimited graphical interface allowing read, write and verify of your STM8 microcontroller Flash program memory, data EEPROM and option bytes. STVP also offers project mode for saving programming configurations and automating programming sequences.

12.1.2 STM-STUDIO

STM-STUDIO helps debug and diagnose STM8 and STM32 applications while they are running by reading and displaying their variables in real-time. STM-STUDIO perfectly complements traditional debugging tools to fine tune applications. It is well suited for debugging applications which cannot be stopped, such as TouchSensing applications. Its easy-to-use, graphical interface features:

- Non-intrusive read on-the-fly variables from RAM while the application is running
- Parse DWARF debugging information in the ELF application executable file
- Possibility to log data into a file, and replay later (exhaustive record display, not real-time)
- 2 types of viewers:
 - Variable viewer: Real-time waveforms, oscilloscope-like graphs
 - TouchPoint viewer: Association of 2 variables, one on the X axis, one on the Y axis

12.1.3 C and assembly toolchains

Control of C and assembly toolchains is seamlessly integrated into the STVD integrated development environment, making it possible to configure and control the building of your application directly from an easy-to-use graphical interface.

Available toolchains include:

- **Cosmic C compiler for STM8** – One free version that outputs up to 32 Kbytes of code is available. For more information, see www.cosmic-software.com.
- **IAR embedded workbench** – The C compiler for STM8 which is included in the toolset is free for up to 8Kbytes of code. For more information, see www.iar.com.
- **Raisonance C compiler for STM8** – One free version that outputs up to 32 Kbytes of code. For more information, see www.raisonance.com.
- **STM8 assembler linker** – Free assembly toolchain included in the STVD toolset, which allows you to assemble and link your application source code.

12.2 Programming tools

During the development cycle, ST-Link provides in-circuit programming of the STM8 Flash microcontroller on your application board via the SWIM protocol.

For production environments, programmers will include a complete range of gang and automated programming solutions from third-party tool developers already supplying programmers for the STM8 family.

13 Revision history

Table 45. Document revision history

Date	Revision	Changes
14-Oct-2011	1	Initial release
04-Apr-2012	2	Added STM8TL52G4, STM8TL52F4, STM8TL53F4 part numbers Added Figure 14 , Figure 16 , Figure 17 , Figure 18 , Figure 19 , Figure 20 , Figure 21 , Figure 22 , Figure 23 , Figure 24 , Figure 25 , Figure 26 Updated Figure 31 and Table 41 Added TSSOP20 package
06-Aug-2013	3	Removed “STICE” references and edited the text in Section 3.2: Development tools and Section 12: STM8 development tools . In Table 7: General hardware register map : – changed the Reset status from “0x00” to “0x01” on “CLK_PCKENR2” row, – split address block “0x00 5055 to 0x00 509F” into “0x00 5055 to 0x00 509D” with “Reserved”, “0x00 509E” with “SYSCFG” and “0x00 509F” with “Reserved”, – added a footnote to RST_SR Reset status value, – updated CLK_CCOR Reset status value to “0x10”. Updated description of OPT0 in Table 11: Option byte description . Updated V _{IN} Max values in Table 13: Voltage characteristics . Added Section 9.3.4: ProxSense Regulator Voltage . Removed ACC _{HSI_PXS} rows from Table 25: HSI_PXS oscillator characteristics and removed former Figure 17 Typical HSI_PXS frequency vs. VDD . Added t _{prog} and I _{prog} Max. values to Table 28: Flash program memory . Removed V _{OL} row with Conditions I _{IO} =+20 mA and V _{DD} =3.0 V from Table 31: I/O static characteristics . Updated “ProxSense I/O” Conditions and Min. values in Table 32: Output driving current (high sink ports) . Added Section 3.13: General purpose and basic timers .
07-Aug-2013	4	Updated OPT0 default value in Table 10: Option bytes .
18-Mar-2015	5	Updated: – Figure 27: SPI timing diagram - slave mode and CPHA = 0 , – Section 10.2: UFQFPN48 package information , – Section 10.3: UFQFPN28 package information , – Section 10.4: TSSOP20 package information . Added: – Figure 33: UFQFPN48 marking example (package top view) , – Figure 36: UFQFPN28 marking example (package top view) , – Figure 39: TSSOP20 marking example (package top view) .

IMPORTANT NOTICE – PLEASE READ CAREFULLY

STMicroelectronics NV and its subsidiaries ("ST") reserve the right to make changes, corrections, enhancements, modifications, and improvements to ST products and/or to this document at any time without notice. Purchasers should obtain the latest relevant information on ST products before placing orders. ST products are sold pursuant to ST's terms and conditions of sale in place at the time of order acknowledgement.

Purchasers are solely responsible for the choice, selection, and use of ST products and ST assumes no liability for application assistance or the design of Purchasers' products.

No license, express or implied, to any intellectual property right is granted by ST herein.

Resale of ST products with provisions different from the information set forth herein shall void any warranty granted by ST for such product.

ST and the ST logo are trademarks of ST. All other product or service names are the property of their respective owners.

Information in this document supersedes and replaces information previously supplied in any prior versions of this document.

© 2015 STMicroelectronics – All rights reserved

