

- Low  $r_{DS(on)}$  . . . 5  $\Omega$  Typical
- Avalanche Energy . . . 30 mJ
- Eight Power DMOS-Transistor Outputs of 150-mA Continuous Current
- 500-mA Typical Current-Limiting Capability
- Output Clamp Voltage . . . 50 V
- Four Distinct Function Modes
- Low Power Consumption

**description**

This power logic 8-bit addressable latch controls open-drain DMOS-transistor outputs and is designed for general-purpose storage applications in digital systems. Specific uses include working registers, serial-holding registers, and decoders or demultiplexers. This is a multi-functional device capable of storing single-line data in eight addressable latches and 3-to-8 decoder or demultiplexer with active-low DMOS outputs.

Four distinct modes of operation are selectable by controlling the clear ( $\overline{CLR}$ ) and enable ( $\overline{G}$ ) inputs as enumerated in the function table. In the addressable-latch mode, data at the data-in (D) terminal is written into the addressed latch. The addressed DMOS-transistor output inverts the data input with all unaddressed DMOS-transistor outputs remaining in their previous states. In the memory mode, all DMOS-transistor outputs remain in their previous states and are unaffected by the data or address inputs. To eliminate the possibility of entering erroneous data in the latch, enable  $\overline{G}$  should be held high (inactive) while the address lines are changing. In the 3-to-8 decoding or demultiplexing mode, the addressed output is inverted with respect to the D input and all other outputs are off. In the clear mode, all outputs are off and unaffected by the address and data inputs. When data is low for a given output, the DMOS-transistor output is off. When data is high, the DMOS-transistor output has sink-current capability.

Outputs are low-side, open-drain DMOS transistors with output ratings of 50 V and 150-mA continuous sink-current capability. Each output provides a 500-mA typical current limit at  $T_C = 25^\circ\text{C}$ . The current limit decreases as the junction temperature increases for additional device protection.

The TPIC6B259 is characterized for operation over the operating case temperature range of  $-40^\circ\text{C}$  to  $125^\circ\text{C}$ .

DW OR N PACKAGE  
(TOP VIEW)

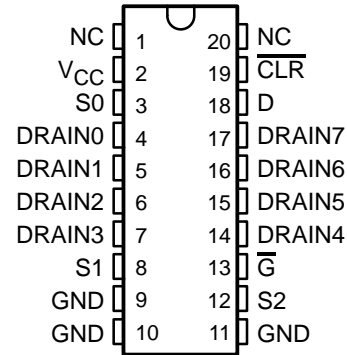

NC – No internal connection

**FUNCTION TABLE**

INPUTS			OUTPUT OF ADDRESSED DRAIN	EACH OTHER DRAIN	FUNCTION
$\overline{CLR}$	$\overline{G}$	D			
H	L	H	L	$Q_{iO}$	Addressable Latch
H	L	L	H	$Q_{iO}$	
H	H	X	$Q_{iO}$	$Q_{iO}$	Memory
L	L	H	L	H	8-Line Demultiplexer
L	L	L	H	H	
L	H	X	H	H	Clear

**LATCH SELECTION TABLE**

SELECT INPUTS			DRAIN ADDRESSED
S2	S1	S0	
L	L	L	0
L	L	H	1
L	H	L	2
L	H	H	3
H	L	L	4
H	L	H	5
H	H	L	6
H	H	H	7

H = high level, L = low level

# TPIC6B259 POWER LOGIC 8-BIT ADDRESSABLE LATCH

SLIS030 – APRIL 1994

## logic symbol†

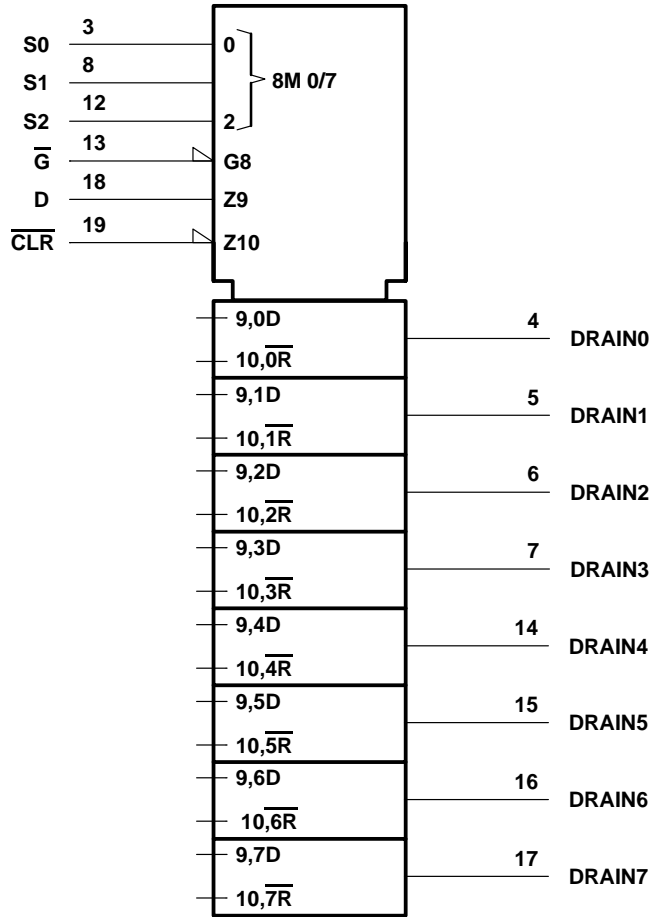

† This symbol is in accordance with ANSI/IEEE Std 91-1984 and IEC Publication 617-12.

logic diagram (positive logic)

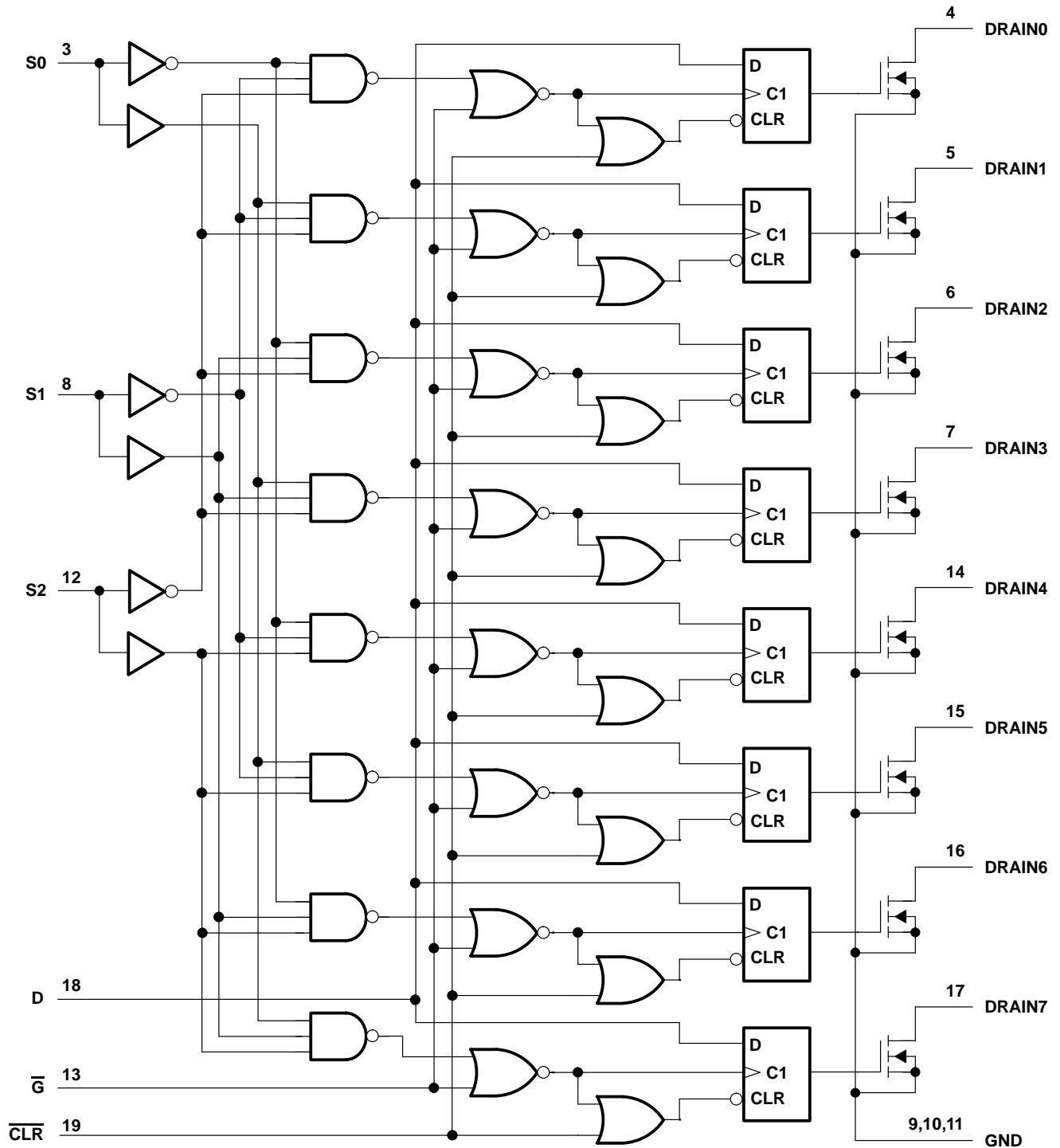

# TPIC6B259 POWER LOGIC 8-BIT ADDRESSABLE LATCH

SLIS030 – APRIL 1994

## schematic of inputs and outputs

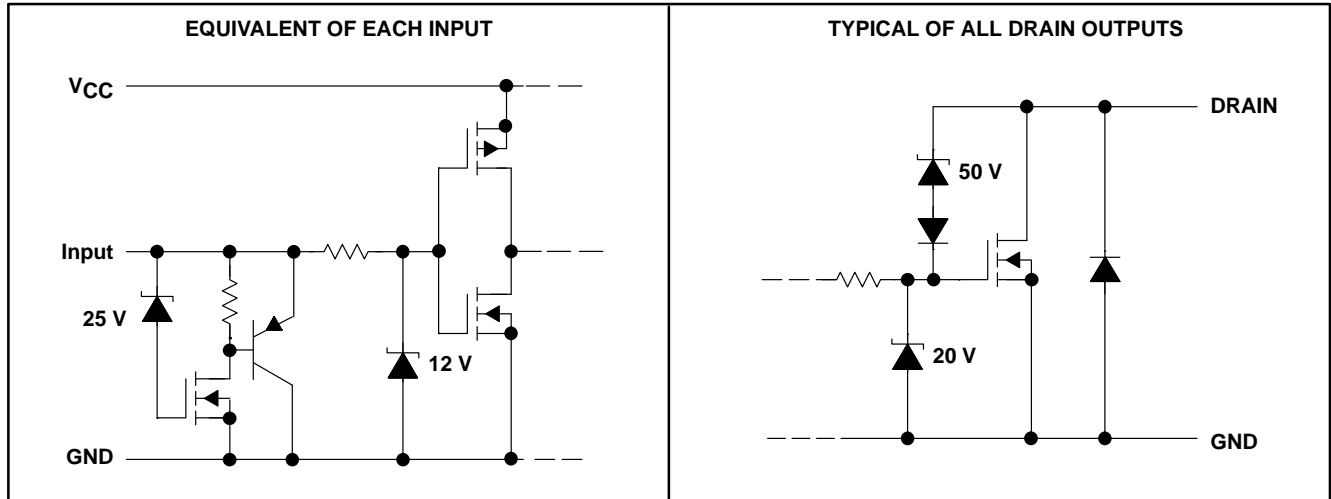

## absolute maximum ratings over the recommended operating case temperature range (unless otherwise noted)†

Logic supply voltage, $V_{CC}$ (see Note 1)	7 V
Logic input voltage range, $V_I$	-0.3 V to 7 V
Power DMOS drain-to-source voltage, $V_{DS}$ (see Note 2)	50 V
Continuous source-to-drain diode anode current	500 mA
Pulsed source-to-drain diode anode current (see Note 3)	1 A
Pulsed drain current, each output, all outputs on, $I_D$ , $T_C = 25^\circ\text{C}$ (see Note 3)	500 mA
Continuous drain current, each output, all outputs on, $I_D$ , $T_C = 25^\circ\text{C}$	150 mA
Peak drain current single output, $I_{DM}$ , $T_C = 25^\circ\text{C}$ (see Note 3)	500 mA
Single-pulse avalanche energy, $E_{AS}$ (see Figure 4)	30 mJ
Avalanche current, $I_{AS}$ (see Note 4)	500 mA
Continuous total dissipation	See Dissipating Rating Table
Operating virtual junction temperature range, $T_J$	-40°C to 150°C
Operating case temperature range, $T_C$	-40°C to 125°C
Storage temperature range	-65°C to 150°C
Lead temperature 1,6 mm (1/16 inch) from case for 10 seconds	260°C

† Stresses beyond those listed under “absolute maximum ratings” may cause permanent damage to the device. These are stress ratings only, and functional operation of the device at these or any other conditions beyond those indicated under “recommended operating conditions” is not implied. Exposure to absolute-maximum-rated conditions for extended periods may affect device reliability.

- NOTES:
- All voltage values are with respect to GND.
  - Each power DMOS source is internally connected to GND.
  - Pulse duration  $\leq 100 \mu\text{s}$  and duty cycle  $\leq 2\%$ .
  - DRAIN supply voltage = 15 V, starting junction temperature ( $T_{JS}$ ) = 25°C,  $L = 200 \text{ mH}$ ,  $I_{AS} = 0.5 \text{ A}$  (see Figure 4).

DISSIPATION RATING TABLE

PACKAGE	$T_C \leq 25^\circ\text{C}$ POWER RATING	DERATING FACTOR ABOVE $T_C = 25^\circ\text{C}$	$T_C = 125^\circ\text{C}$ POWER RATING
DW	1389 mW	11.1 mW/°C	278 mW
N	1050 mW	10.5 mW/°C	263 mW

**recommended operating conditions**

	MIN	MAX	UNIT
Logic supply voltage, $V_{CC}$	4.5	5.5	V
High-level input voltage, $V_{IH}$	0.85 $V_{CC}$		V
Low-level input voltage, $V_{IL}$	0.15 $V_{CC}$		V
Pulsed drain output current, $T_C = 25^\circ\text{C}$ , $V_{CC} = 5\text{ V}$ (see Notes 3 and 5)	-500	500	mA
Setup time, D high before $\overline{G}\uparrow$ , $t_{SU}$ (see Figure 2)	20		ns
Hold time, D high after $\overline{G}\uparrow$ , $t_H$ (see Figure 2)	20		ns
Pulse duration, $t_W$ (see Figure 2)	40		ns
Operating case temperature, $T_C$	-40	125	$^\circ\text{C}$

**electrical characteristics,  $V_{CC} = 5\text{ V}$ ,  $T_C = 25^\circ\text{C}$  (unless otherwise noted)**

PARAMETER	TEST CONDITIONS	MIN	TYP	MAX	UNIT
$V_{(BR)DSX}$ Drain-to-source breakdown voltage	$I_D = 1\text{ mA}$	50			V
$V_{SD}$ Source-to-drain diode forward voltage	$I_F = 100\text{ mA}$		0.85	1	V
$I_{IH}$ High-level input current	$V_{CC} = 5.5\text{ V}$ , $V_I = V_{CC}$			1	$\mu\text{A}$
$I_{IL}$ Low-level input current	$V_{CC} = 5.5\text{ V}$ , $V_I = 0$			-1	$\mu\text{A}$
$I_{CC}$ Logic supply current	$V_{CC} = 5.5\text{ V}$	All outputs off	20	100	$\mu\text{A}$
		All outputs on	150	300	
$I_N$ Nominal current	$V_{DS(on)} = 0.5\text{ V}$ , $I_N = I_D$ , $T_C = 85^\circ\text{C}$ , See Notes 5, 6, and 7		90		mA
$I_{DSX}$ Off-state drain current	$V_{DS} = 40\text{ V}$ , $V_{CC} = 5.5\text{ V}$		0.1	5	$\mu\text{A}$
	$V_{DS} = 40\text{ V}$ , $V_{CC} = 5.5\text{ V}$ , $T_C = 125^\circ\text{C}$		0.15	8	
$r_{DS(on)}$ Static drain-to-source on-state resistance	$I_D = 100\text{ mA}$ , $V_{CC} = 4.5\text{ V}$	See Notes 5 and 6 and Figures 6 and 7	4.2	5.7	$\Omega$
	$I_D = 100\text{ mA}$ , $V_{CC} = 4.5\text{ V}$ , $T_C = 125^\circ\text{C}$		6.8	9.5	
	$I_D = 350\text{ mA}$ , $V_{CC} = 4.5\text{ V}$		5.5	8	

**switching characteristics,  $V_{CC} = 5\text{ V}$ ,  $T_C = 25^\circ\text{C}$**

PARAMETER	TEST CONDITIONS	MIN	TYP	MAX	UNIT
$t_{PLH}$ Propagation delay time, low-to-high-level output from D	$C_L = 30\text{ pF}$ , $I_D = 100\text{ mA}$ , See Figures 1, 2, and 8		150		ns
$t_{PHL}$ Propagation delay time, high-to-low-level output from D			90		ns
$t_r$ Rise time, drain output			200		ns
$t_f$ Fall time, drain output			200		ns
$t_a$ Reverse-recovery-current rise time		$I_F = 100\text{ mA}$ , $di/dt = 20\text{ A}/\mu\text{s}$ ,		100	
$t_{rr}$ Reverse-recovery time	See Notes 5 and 6 and Figure 3		300		

- NOTES: 3. Pulse duration  $\leq 100\ \mu\text{s}$  and duty cycle  $\leq 2\%$ .  
 5. Technique should limit  $T_J - T_C$  to  $10^\circ\text{C}$  maximum.  
 6. These parameters are measured with voltage-sensing contacts separate from the current-carrying contacts.  
 7. Nominal current is defined for a consistent comparison between devices from different sources. It is the current that produces a voltage drop of 0.5 V at  $T_C = 85^\circ\text{C}$ .

# TPIC6B259 POWER LOGIC 8-BIT ADDRESSABLE LATCH

SLIS030 – APRIL 1994

## thermal resistance

PARAMETER		TEST CONDITIONS	MIN	MAX	UNIT
R <sub>θJA</sub>	Thermal resistance junction-to-ambient	DW package		90	°C/W
		N package	All 8 outputs with equal power	95	

## PARAMETER MEASUREMENT INFORMATION

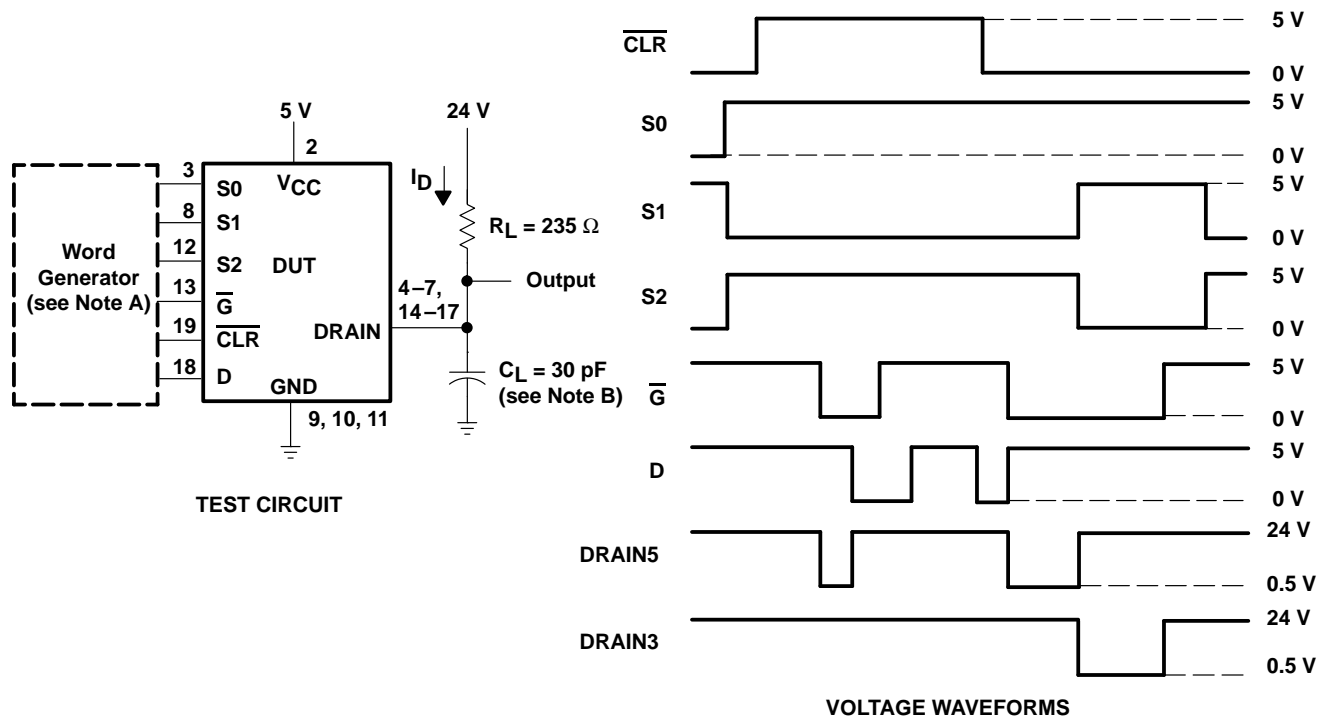

- NOTES: A. The word generator has the following characteristics:  $t_r \leq 10$  ns,  $t_f \leq 10$  ns,  $t_w = 300$  ns, pulsed repetition rate (PRR) = 5 kHz,  $Z_0 = 50$  Ω.  
B. C<sub>L</sub> includes probe and jig capacitance.

Figure 1. Resistive-Load Test Circuit and Voltage Waveforms

PARAMETER MEASUREMENT INFORMATION

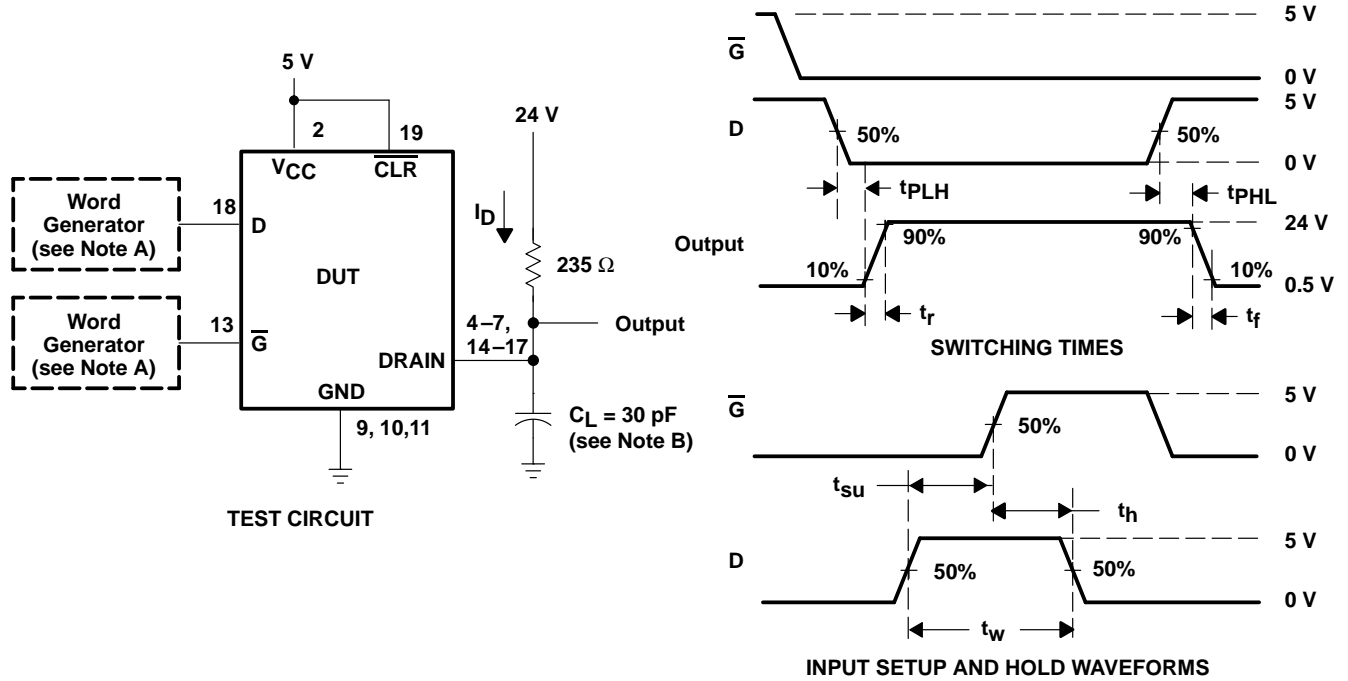

- NOTES: A. The word generator has the following characteristics:  $t_r \leq 10$  ns,  $t_f \leq 10$  ns,  $t_w = 300$  ns, pulsed repetition rate (PRR) = 5 kHz,  $Z_0 = 50 \Omega$ .  
B.  $C_L$  includes probe and jig capacitance.

Figure 2. Test Circuit, Switching Times, and Voltage Waveforms

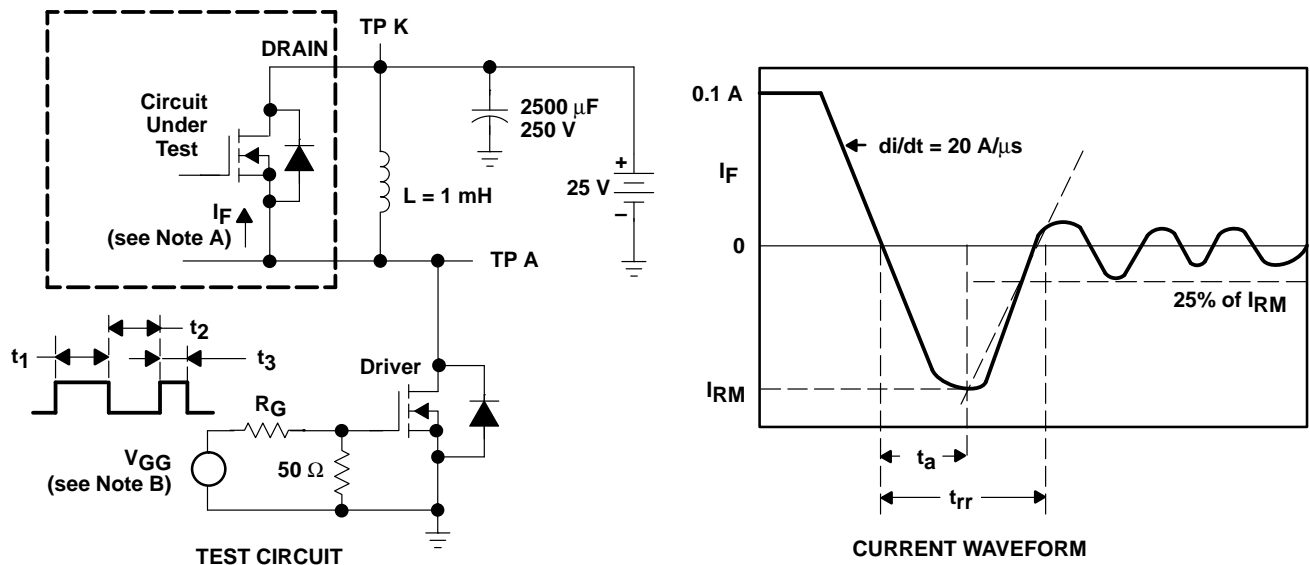

- NOTES: A. The DRAIN terminal under test is connected to the TP K test point. All other terminals are connected together and connected to the TP A test point.  
B. The  $V_{GG}$  amplitude and  $R_G$  are adjusted for  $di/dt = 20$  A/ $\mu$ s. A  $V_{GG}$  double-pulse train is used to set  $I_F = 0.1$  A, where  $t_1 = 10 \mu$ s,  $t_2 = 7 \mu$ s, and  $t_3 = 3 \mu$ s.

Figure 3. Reverse-Recovery-Current Test Circuit and Waveforms of Source-to-Drain Diode

# TPIC6B259 POWER LOGIC 8-BIT ADDRESSABLE LATCH

SLIS030 – APRIL 1994

## PARAMETER MEASUREMENT INFORMATION

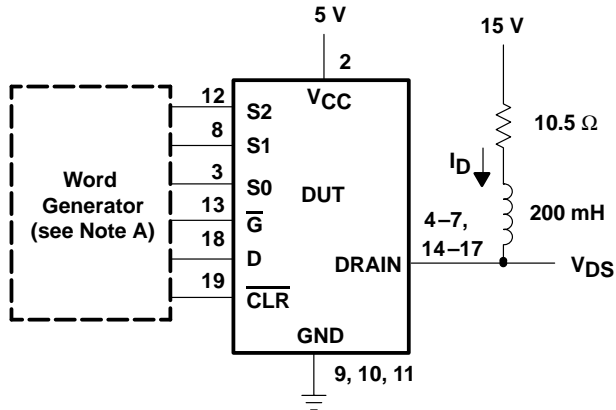

TEST CIRCUIT

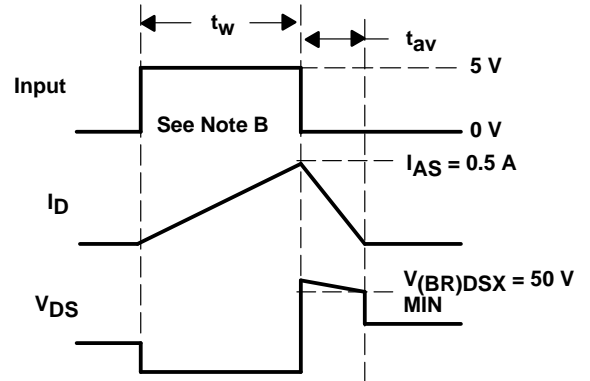

VOLTAGE AND CURRENT WAVEFORMS

- NOTES: A. The word generator has the following characteristics:  $t_r \leq 10$  ns,  $t_f \leq 10$  ns,  $Z_O = 50 \Omega$ .  
 B. Input pulse duration,  $t_w$ , is increased until peak current  $I_{AS} = 0.5$  A.  
 Energy test level is defined as  $E_{AS} = I_{AS} \times V_{(BR)DSX} \times t_{av}/2 = 30$  mJ.

Figure 4. Single-Pulse Avalanche Energy Test Circuit and Waveforms

## TYPICAL CHARACTERISTICS

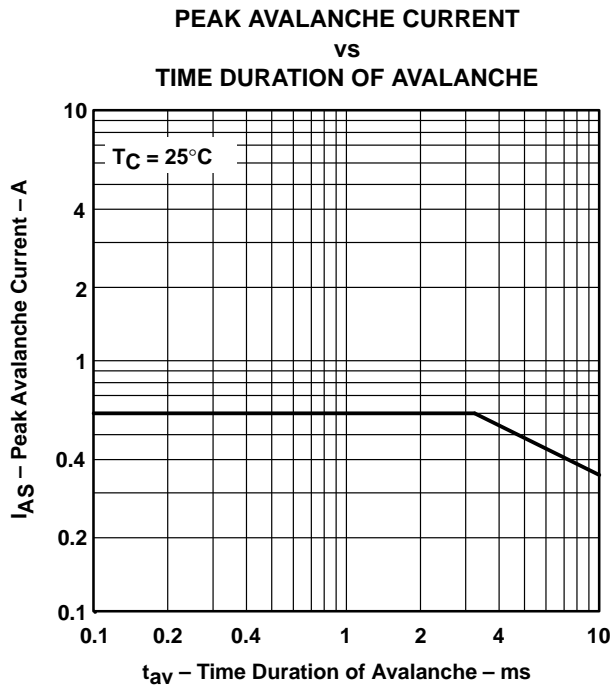
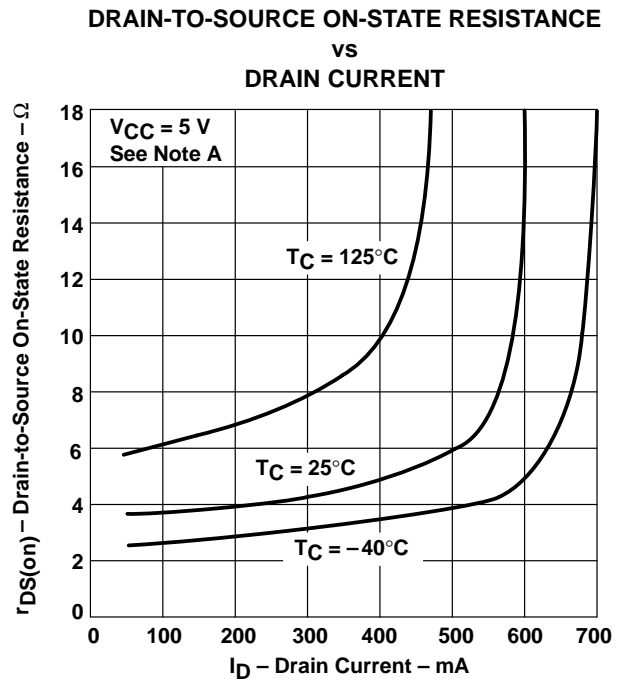

Figure 5



NOTE A: Technique should limit  $T_J - T_C$  to  $10^\circ\text{C}$  maximum.

Figure 6



TYPICAL CHARACTERISTICS

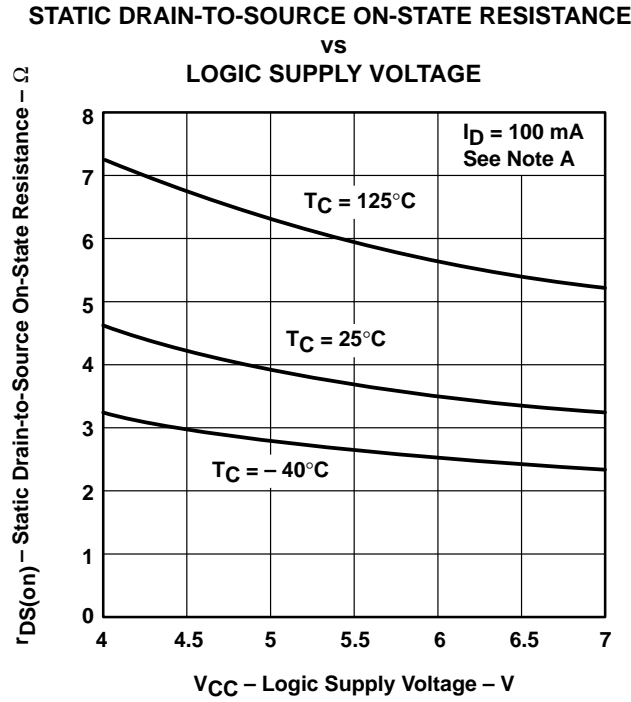

Figure 7

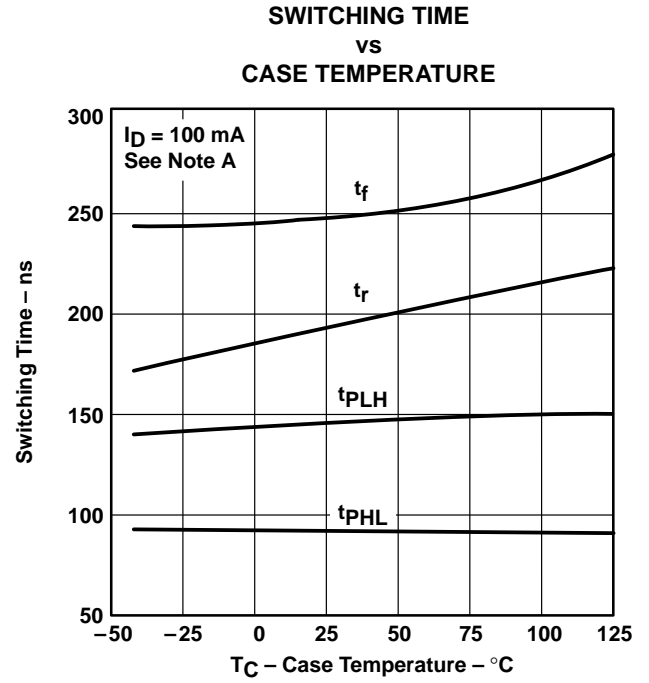

Figure 8

NOTE A: Technique should limit  $T_J - T_C$  to  $10^\circ\text{C}$  maximum.

# TPIC6B259 POWER LOGIC 8-BIT ADDRESSABLE LATCH

SLIS030 – APRIL 1994

## THERMAL INFORMATION

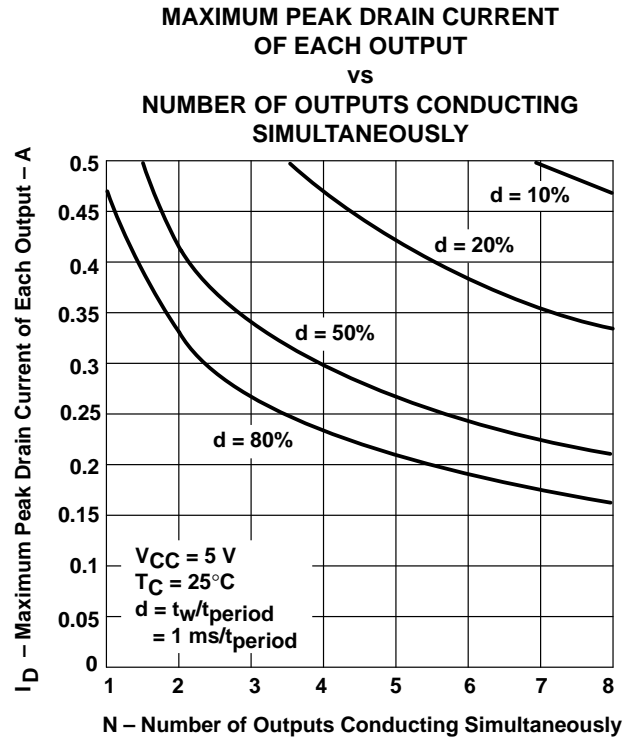
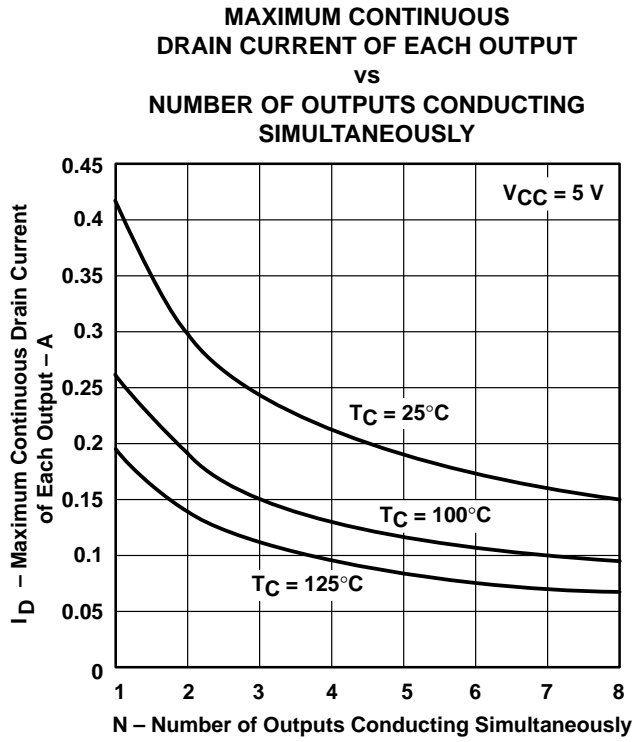



## **IMPORTANT NOTICE**

Texas Instruments (TI) reserves the right to make changes to its products or to discontinue any semiconductor product or service without notice, and advises its customers to obtain the latest version of relevant information to verify, before placing orders, that the information being relied on is current.

TI warrants performance of its semiconductor products and related software to the specifications applicable at the time of sale in accordance with TI's standard warranty. Testing and other quality control techniques are utilized to the extent TI deems necessary to support this warranty. Specific testing of all parameters of each device is not necessarily performed, except those mandated by government requirements.

Certain applications using semiconductor products may involve potential risks of death, personal injury, or severe property or environmental damage ("Critical Applications").

**TI SEMICONDUCTOR PRODUCTS ARE NOT DESIGNED, INTENDED, AUTHORIZED, OR WARRANTED TO BE SUITABLE FOR USE IN LIFE-SUPPORT APPLICATIONS, DEVICES OR SYSTEMS OR OTHER CRITICAL APPLICATIONS.**

Inclusion of TI products in such applications is understood to be fully at the risk of the customer. Use of TI products in such applications requires the written approval of an appropriate TI officer. Questions concerning potential risk applications should be directed to TI through a local SC sales office.

In order to minimize risks associated with the customer's applications, adequate design and operating safeguards should be provided by the customer to minimize inherent or procedural hazards.

TI assumes no liability for applications assistance, customer product design, software performance, or infringement of patents or services described herein. Nor does TI warrant or represent that any license, either express or implied, is granted under any patent right, copyright, mask work right, or other intellectual property right of TI covering or relating to any combination, machine, or process in which such semiconductor products or services might be or are used.