

TPS65735

PMU For Active Shutter 3D Glasses

Data Manual



PRODUCTION DATA information is current as of publication date. Products conform to specifications per the terms of the Texas Instruments standard warranty. Production processing does not necessarily include testing of all parameters.

Literature Number: SLVSAI6
June 2011

Contents

1	INTRODUCTION	5
1.1	Features	5
1.2	Description	5
1.3	Pin Descriptions	6
1.4	Package Pin Assignments	7
2	POWER MANAGEMENT CORE	8
2.1	Recommended Operating Conditions	8
2.2	Absolute Maximum Ratings	8
2.3	Thermal Information	9
2.4	Quiescent Current	9
2.5	Electrical Characteristics	9
2.6	System Operation	13
2.6.1	System Power Up	13
2.6.2	System Operation Using Push Button Switch	14
2.6.3	System Operation Using Slider Switch	15
2.7	Linear Charger Operation	16
2.7.1	Battery and TS Detection	16
2.7.2	Battery Charging	16
2.7.2.1	Pre-charge	17
2.7.2.2	Charge Termination	17
2.7.2.3	Recharge	17
2.7.2.4	Charge Timers	17
2.7.3	Charger Status (nCHG_STAT Pin)	18
2.8	LDO Operation	18
2.8.1	LDO Internal Current Limit	18
2.9	Boost Converter Operation	19
2.9.1	Boost Thermal Shutdown	19
2.9.2	Boost Load Disconnect	20
2.10	Full H-Bridge Analog Switches	20
2.10.1	H-Bridge Switch Control	20
2.11	Power Management Core Control	22
2.11.1	SLEEP / Power Control Pin Function	22
2.11.2	COMP Pin Functionality	22
2.11.3	SW_SEL Pin Functionality	23
2.11.4	SWITCH Pin	23
2.11.5	Slider Switch Behavior	23
2.11.6	Push-Button Switch Behavior	24
3	APPLICATION INFORMATION	26
3.1	Applications Schematic	26
3.2	Reducing System Quiescent Current (I_Q)	26
3.3	Boost Converter Application Information	27
3.3.1	Setting Boost Output Voltage	27
3.3.2	Boost Inductor Selection	28
3.3.3	Boost Capacitor Selection	28
3.4	Bypassing Default Push-Button SWITCH Functionality	28

List of Figures

1-1	TPS65735 Functional Block Diagram	5
1-2	TPS65735 Package Pin Assignments	7
2-1	System Power Up State Diagram	14
2-2	Push Button State Diagram	15
2-3	System Operation Using Slider Switch	15
2-4	Thermistor Detection and Circuit	16
2-5	Battery Charge Phases	17
2-10	Boost Load Disconnect	20
2-11	H-Bridge States	21
2-12	H-Bridge States from Oscilloscope	22
2-13	SLEEP Signal to Force System Power Off	22
2-14	COMP Pin Internal Connection	22
2-15	SWITCH, Slider Power On-Off Behavior	24
2-16	SWITCH, Push-button Power On Behavior	25
2-17	SWITCH, Push-button Power Off Behavior	25
3-1	TPS65735 Applications Schematic	26
3-2	Reducing System I_Q with Addition of a FET	27
3-3	Boost Feedback Network Schematic	27
3-4	Bypassing Default TPS65735 Push Button SWITCH Timing	29
3-5	SWITCH Press and SLEEP Signal to Control System Power Off	29

List of Tables

1-1	Pin Descriptions	6
1-2	Pin Absolute Maximum Ratings.....	7
2-1	nCHG_STAT Functionality	18
2-2	VLDO_SET Functionality.....	18
2-3	H-Bridge States from Inputs	21
2-4	Scaling Resistors for COMP Pin Function ($V_{VLDO} = 2.2\text{ V}$)	23
2-5	Scaling Resistors for COMP Pin Function ($V_{VLDO} = 3.0\text{ V}$)	23
2-6	SW_SEL Settings	23
3-1	Recommended R_{FB1} and R_{FB2} Values (for $I_{Q(FB)} = 5\text{ }\mu\text{A}$)	28

PMU For Active Shutter 3D Glasses

Check for Samples: [TPS65735](#)

1 INTRODUCTION

1.1 Features

- **Linear Charger**
 - Three Charger Phases: Pre-charge, Fast Charge, and Charge Termination
 - Externally Set Charge Current, Supports up to 100 mA
 - LED Current Sinks for Power Good and Charger Status Indication
- **LDO Supply for External Modules (Microcontroller, RF Module, IR Module)**
 - LDO Continuous Output Current up to 30 mA
- **Boost Converter**
 - Adjustable Output Voltage: 8 V to 16 V
 - Boost Output Internally Connected to H-Bridge Analog Switches
- **Full H-Bridge Analog Switches**
 - Controlled by an External Microcontroller for System Operation
- **Output Pin for Divided Down Battery Voltage Useful for ADC or Comparator Input of an MCU**

1.2 Description

The TPS65735 is a PMU for active shutter 3D glasses consisting of an integrated power path, linear charger, LDO, boost converter, and full H-bridge analog switches for left and right shutter operation in a pair of active shutter 3D glasses. In addition to the power devices, a typical 3D glasses system contains both a microcontroller and a communications front end (IR, RF, or other) in order to handle the communication and synchronous operation along with a 3D television.

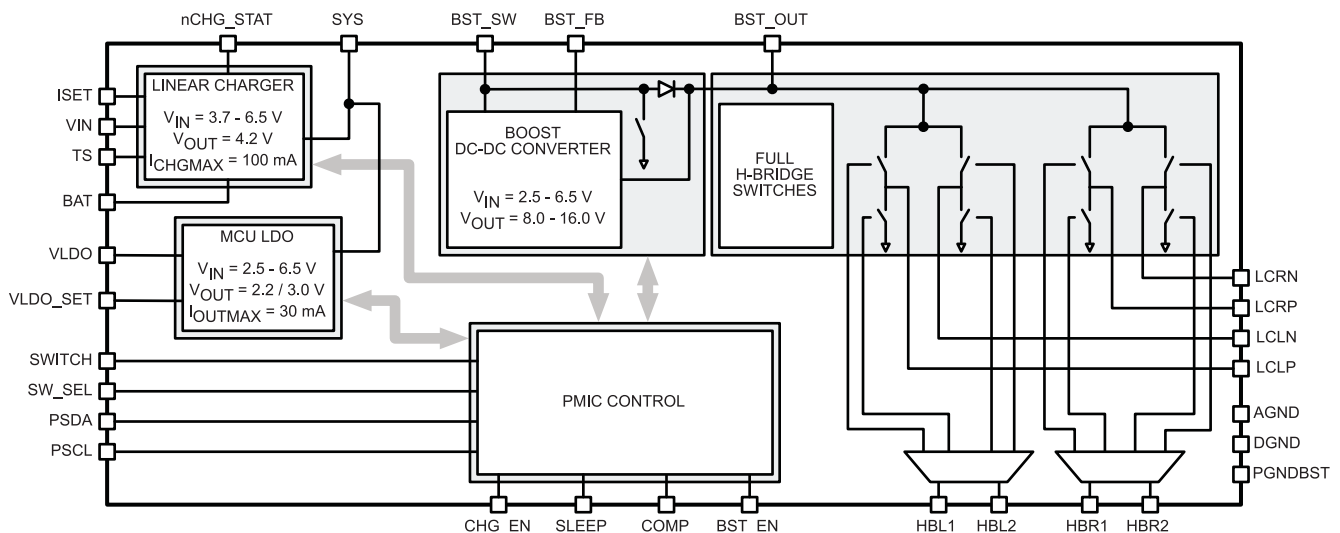

Figure 1-1. TPS65735 Functional Block Diagram



Please be aware that an important notice concerning availability, standard warranty, and use in critical applications of Texas Instruments semiconductor products and disclaimers thereto appears at the end of this data sheet.

1.3 Pin Descriptions

Table 1-1. Pin Descriptions

PIN NAME	I/O	PIN NO.	DESCRIPTION
POWER MANAGEMENT CORE (PMIC)			
VIN	I	20	AC or USB Adapter Input
ISET	I/O	15	Fast-Charge Current Setting Resistor
TS	I	16	Pin for 10 kΩ NTC Thermistor Connection FLOAT IF THERMISTOR / TS FUNCTION IS NOT USED
nCHG_STAT	O	29	Open-drain Output, Charge Status Indication CONNECT TO GROUND IF FUNCTION IS NOT USED
BAT	I/O	18	Charger Power Stage Output and Battery Voltage Sense Input
SYS	O	19	Output Terminal to System
VLDO	O	21	LDO Output
VLDO_SET	I	22	Sets LDO Output Voltage (see Table 2-2)
SWITCH	I	25	Switch Input for Device Power On/Off
SW_SEL	I	26	Selects Type of Switch Connected to SWITCH Pin (see Table 2-6)
BST_SW	O	11	Boost Switch Node
BST_FB	I	13	Boost Feedback Node
BST_OUT	O	10	Boost Output
HBR1	I	8	H-Bridge Input 1 for Right LC Shutter
HBR2	I	9	H-Bridge Input 2 for Right LC Shutter
HBL1	I	32	H-Bridge Input 1 for Left LC Shutter
HBL2	I	7	H-Bridge Input 2 for Left LC Shutter
LCRN	O	6	H-Bridge Output for Right LC Shutter, "Negative" Terminal
LCRP	O	5	H-Bridge Output for Right LC Shutter, "Positive" Terminal
LCLN	O	4	H-Bridge Output for Left LC Shutter, "Negative" Terminal
LCLP	O	3	H-Bridge Output for Left LC Shutter, "Positive" Terminal
COMP	O	23	Scaled Battery Voltage for MCU Comparator or ADC Input (Battery Voltage Monitoring) DO NOT CONNECT IF COMP FUNCTION IS NOT USED
SLEEP	I/O	31	Sleep Enable Input from an MCU (edge triggered, only for system shutdown)
BST_EN	I	1	Boost Enable Input from an MCU, High = Boost Enabled
CHG_EN	I	30	Charger Enable Input from an MCU, High = Boost Enabled
PSCL	I/O	28	I ² C Clock Pin (only used for TI debug and test) GROUND PIN IN APPLICATION
PSDA	I/O	27	I ² C Data Pin (only used for TI debug and test) GROUND PIN IN APPLICATION
PGNDBST	-	12	Boost Power Ground
AGND	-	24	Analog Ground
DGND	-	2	Digital Ground
MISC. AND PACKAGE			
Thermal PAD	-	33	There is an internal electrical connection between the exposed thermal pad and the AGND ground pin of the device. The thermal pad must be connected to the same potential as the AGND pin on the printed circuit board. Do not use the thermal pad as the primary ground input for the device. AGND pin must be connected to ground at all times.
N/C	-	14, 17	All N/C should be connected to the main system ground.

Table 1-2. Pin Absolute Maximum Ratings

PIN	VALUE / UNIT
Input voltage range on all pins (except for VIN, BST_OUT, BST_SW, BST_FB, VLDO, LCLP, LCLN, LCRP, LCRN, AGND, DGND, and PGNDBST) with respect to AGND	-0.3 V to 7.0 V
VIN with respect to AGND	-0.3 V to 28.0 V
BST_OUT, BST_SW, LCLP, LCLN, LCRP, and LCRN with respect to PGNDBST	-0.3 V to 18.0 V
BST_FB with respect to PGNDBST, VLDO with respect to DGND	-0.3 V to 3.6 V

1.4 Package Pin Assignments

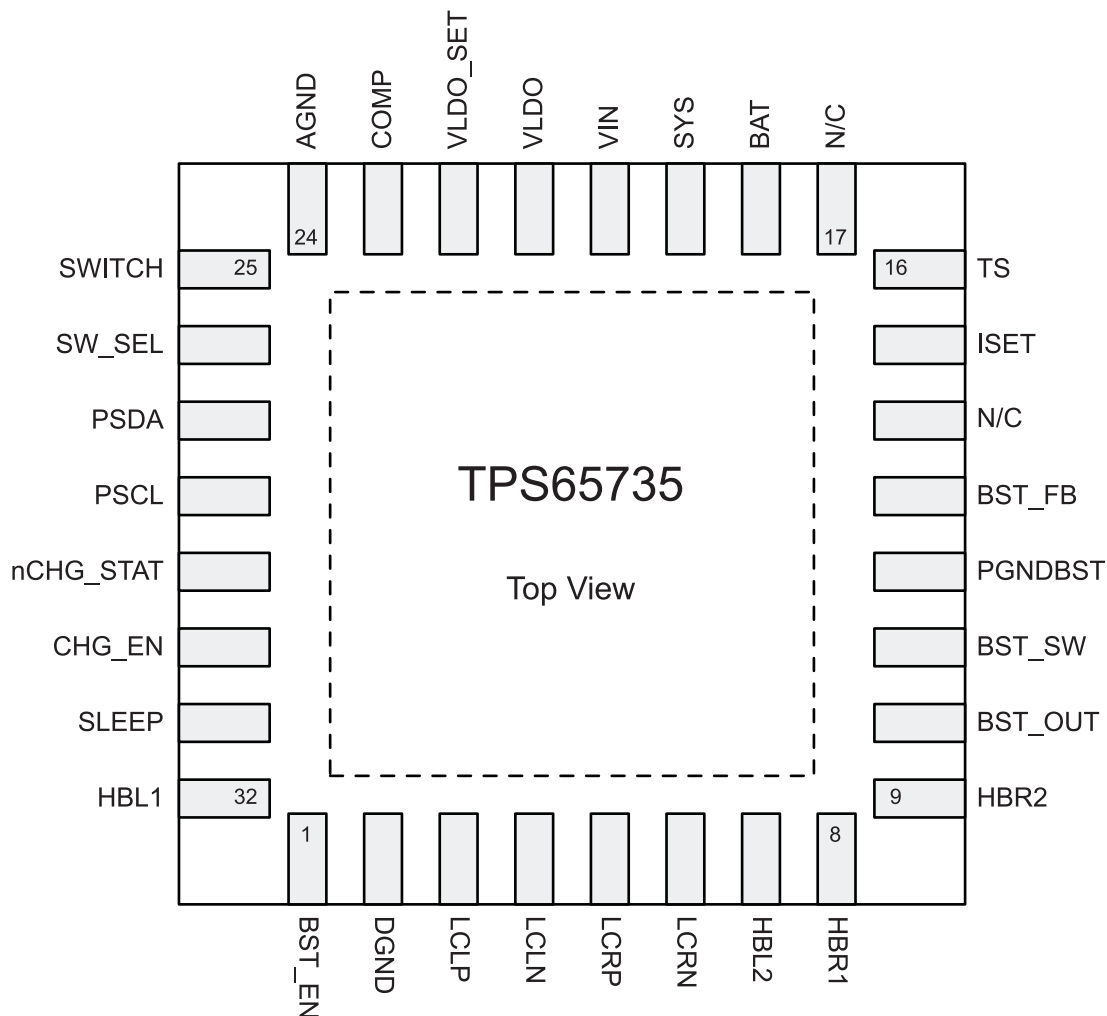

Pins 14 & 17 = N/C. No internal connection, connect to main system ground.

Figure 1-2. TPS65735 Package Pin Assignments

2 POWER MANAGEMENT CORE

2.1 Recommended Operating Conditions

over operating free-air temperature range (unless otherwise noted)

SUBSYSTEM AND PARAMETER		MIN	NOM	MAX	UNIT
CHARGER / POWER PATH					
V_{VIN}	Voltage range at charger input pin	3.7		28	V
I_{VIN}	Input current at VIN pin			200	mA
C_{VIN}	Capacitor on VIN pin	0.1		10	μ F
L_{VIN}	Inductance at VIN pin	0		2	μ H
V_{SYS}	Voltage range at SYS pin	2.5		6.4	V
$I_{SYS(OUT)}$	Output current at SYS pin			100	mA
C_{SYS}	Capacitor on SYS pin	0.1		10	μ F
V_{BAT}	Voltage range at BAT pin	2.5		6.4	V
C_{BAT}	Capacitor on BAT pin	4.7		10	μ F
$R_{EXT(nCHG_STAT)}$	Resistor connected to nCHG_STAT pin to limit current into pin	320			Ω
BOOST CONVERTER / H-BRIDGE SWITCHES					
$V_{IN(BST_SW)}$	Input voltage range for boost converter	2.5		6.5	V
V_{BST_OUT}	Output voltage range for boost converter	8		16	V
C_{BST_OUT}	Boost output capacitor	3.3		10	μ F
$L_{BST_SW}^{(1)}$	Inductor connected between SYS and BST_SW pins Device optimized for operation with 10 μ H inductor	4.7		10	μ H
LDO					
C_{VLDO}	External decoupling cap on pin VLDO	1		10	μ F
POWER MANAGEMENT CORE CONTROL (LOGIC LEVELS FOR GPIOs)					
$V_{IL(PMIC)}$	GPIO low level (BST_EN, CHG_EN, SW_SEL, VLDO_SET and to switch H-Bridge inputs to a low, 0, level)			0.4	V
$V_{IH(PMIC)}$	GPIO high level (BST_EN, CHG_EN, SW_SEL, VLDO_SET and to switch H-Bridge inputs to a high, 1, level)	1.2			V

(1) See [Section 2.9](#) for information on boost converter inductor selection.

2.2 Absolute Maximum Ratings

over operating free-air temperature range (unless otherwise noted)

PARAMETER	MINIMUM	MAXIMUM	UNITS
Operating free-air temperature, T_A	0	60	$^{\circ}$ C
Max Junction Temperature, T_J , Electrical Characteristics Guaranteed	0	85	$^{\circ}$ C
Max Junction temperature, T_J , Functionality Guaranteed ⁽¹⁾	0	105	$^{\circ}$ C

(1) Device has a thermal shutdown feature implemented that shuts down at 105 $^{\circ}$ C

2.3 Thermal Information

THERMAL METRIC		TPS65735	UNITS
		RSN	
		32 PINS	
θ_{JA}	Junction-to-ambient thermal resistance ⁽¹⁾	38.9	°C/W
θ_{JCTop}	Junction-to-case (top) thermal resistance ⁽²⁾	26.5	
θ_{JB}	Junction-to-board thermal resistance ⁽³⁾	9.8	
Ψ_{JT}	Junction-to-top characterization parameter ⁽⁴⁾	0.3	
Ψ_{JB}	Junction-to-board characterization parameter ⁽⁵⁾	9.8	
θ_{JCbott}	Junction-to-case (bottom) thermal resistance ⁽⁶⁾	3.5	

- (1) The junction-to-ambient thermal resistance under natural convection is obtained in a simulation on a JEDEC-standard, high-K board, as specified in JESD51-7, in an environment described in JESD51-2a.
- (2) The junction-to-case (top) thermal resistance is obtained by simulating a cold plate test on the package top. No specific JEDEC-standard test exists, but a close description can be found in the ANSI SEMI standard G30-88.
- (3) The junction-to-board thermal resistance is obtained by simulating in an environment with a ring cold plate fixture to control the PCB temperature, as described in JESD51-8.
- (4) The junction-to-top characterization parameter, Ψ_{JT} , estimates the junction temperature of a device in a real system and is extracted from the simulation data for obtaining θ_{JA} , using a procedure described in JESD51-2a (sections 6 and 7).
- (5) The junction-to-board characterization parameter, Ψ_{JB} , estimates the junction temperature of a device in a real system and is extracted from the simulation data for obtaining θ_{JA} , using a procedure described in JESD51-2a (sections 6 and 7).
- (6) The junction-to-case (bottom) thermal resistance is obtained by simulating a cold plate test on the exposed (power) pad. No specific JEDEC standard test exists, but a close description can be found in the ANSI SEMI standard G30-88.

2.4 Quiescent Current

over operating free-air temperature range (unless otherwise noted)

PARAMETER		TEST CONDITIONS	MIN	TYP	MAX	UNIT
$I_{Q(SLEEP)}$	Power management core quiescent current in sleep mode	@ 25° C $V_{BAT} = 3.6\text{ V}$ $V_{VIN} = 0\text{ V}$ No load on LDO CHG_EN, BST_EN grounded BST_FB = 300 mV Power management core in sleep mode / device 'off'		8.6	10.5	μA
$I_{Q(ACTIVE)}$	Power management core quiescent current in active mode	@ 25° C $V_{BAT} = 3.6\text{ V}$ $V_{VIN} = 0\text{ V}$ Boost enabled but not switching, H-bridge in grounded state No load on LDO Power management core in active mode		39	53.5	μA

2.5 Electrical Characteristics

over operating free-air temperature range (unless otherwise noted)

PARAMETER		TEST CONDITIONS	MIN	TYP	MAX	UNIT
BATTERY CHARGER POWER PATH						
$V_{UVLO(VIN)}$	Undervoltage lockout at power path input, VIN pin	$V_{VIN}: 0\text{ V} \rightarrow 4\text{ V}$	3.2	3.3	3.45	V
$V_{HYS-UVLO(VIN)}$	Hysteresis on UVLO at power path input, VIN pin	$V_{VIN}: 4\text{ V} \rightarrow 0\text{ V}$	200		300	mV
V_{IN-DT}	Input power detection threshold	Input power detected if: ($V_{VIN} > V_{BAT} + V_{IN-DT}$); $V_{BAT} = 3.6\text{ V}$ $V_{VIN}: 3.5\text{ V} \rightarrow 4\text{ V}$	40		140	mV
$V_{HYS-INDT}$	Hysteresis on V_{IN-DT}	$V_{BAT} = 3.6\text{ V}$ $V_{VIN}: 4\text{ V} \rightarrow 3.5\text{ V}$	20			mV

Electrical Characteristics (continued)

over operating free-air temperature range (unless otherwise noted)

PARAMETER		TEST CONDITIONS	MIN	TYP	MAX	UNIT
V _{OVP}	Input over-voltage protection threshold	V _{VIN} : 5 V → 7 V	6.4	6.6	6.8	V
V _{HYS-OVP}	Hysteresis on OVP	V _{VIN} : 11 V → 5 V		105		mV
V _{DO(VIN-SYS)}	VIN pin to SYS pin dropout voltage V _{VIN} – V _{SYS}	I _{SYS} = 150 mA (including I _{BAT}) V _{VIN} = 4.35 V V _{BAT} = 3.6 V			350	mV
V _{DO(BAT-SYS)}	BAT pin to SYS pin dropout voltage V _{BAT} – V _{SYS}	I _{SYS} = 100 mA V _{VIN} = 0 V V _{BAT} > 3 V			150	mV
I _{VIN(MAX)}	Maximum power path input current at pin VIN	V _{VIN} = 5 V		200		mA
V _{SUP(ENT)}	Enter battery supplement mode			V _{SYS} ≤ (V _{BAT} - 40 mV)		V
V _{SUP(EXIT)}	Exit battery supplement mode			V _{SYS} ≥ (V _{BAT} - 20 mV)		V
V _{SUP(SC)}	Output short-circuit limit in supplement mode			250		mV
V _{O(SC)}	Output short-circuit detection threshold, power-on			0.9		V
BATTERY CHARGER						
I _{CC}	Active supply current into VIN pin	V _{VIN} = 5 V No load on SYS pin V _{BAT} > V _{BAT(REG)}			2	mA
I _{BAT(SC)}	Source current for BAT pin short-circuit detection			1		mA
V _{BAT(SC)}	BAT pin short-circuit detection threshold		1.6	1.8	2.0	V
V _{BAT(REG)}	Battery charger output voltage		-1%	4.20	1%	V
V _{LOWV}	Pre-charge to fast-charge transition threshold		2.9	3.0	3.1	V
I _{CHG}	Charger fast charge current range I _{CHG} = K _{ISET} / R _{ISET}	V _{VIN} = 5 V V _{BAT(REG)} > V _{BAT} > V _{LOWV}		5	100	mA
K _{ISET}	Battery fast charge current set factor I _{CHG} = K _{ISET} / R _{ISET}	V _{VIN} = 5 V I _{VIN(MAX)} > I _{CHG} I _{CHG} = 100 mA No load on SYS pin, thermal loop not active.	-20%	450	20%	AΩ
I _{PRECHG}	Pre-charge current		0.07 × I _{CHG}	0.10 × I _{CHG}	0.15 × I _{CHG}	mA
I _{TERM}	Charge current value for termination detection threshold	I _{CHG} = 100 mA	7	10	15	mA
V _{RCH}	Recharge detection threshold	V _{BAT} below nominal charger voltage, V _{BAT(REG)}	55	100	170	mV
I _{BAT(DET)}	Sink current for battery detection			1		mA
t _{CHG}	Charge safety timer (18000 seconds = 5 hours)			18000		s
t _{PRECHG}	Pre-charge timer (1800 seconds = 30 minutes)			1800		s
V _{DPPM}	DPPM threshold			V _{BAT} + 100 mV		V
I _{LEAK(nCHG)}	Leakage current for nCHG_STAT pin	V _{nCHG_STAT} = 4.2 V CHG_EN = LOW (Charger disabled)			100	nA
R _{DSON(nCHG)}	On resistance for nCHG_STAT MOSFET switch			20	60	Ω

Electrical Characteristics (continued)

over operating free-air temperature range (unless otherwise noted)

PARAMETER		TEST CONDITIONS	MIN	TYP	MAX	UNIT
$I_{MAX(nCHG)}$	Maximum input current to nCHG_STAT pin				50	mA
BATTERY CHARGER NTC MONITOR						
I_{TSBIAS}	TS pin bias current			75		μ A
V_{COLD}	0°C charge threshold for 10k Ω NTC ($\beta = 3490$)			2100		mV
$V_{HYS(COLD)}$	Low temperature threshold hysteresis	Battery charging and battery / NTC temperature increasing		300		mV
V_{HOT}	50°C charge threshold for 10k Ω NTC ($\beta = 3490$)			300		mV
$V_{HYS(HOT)}$	High temperature threshold hysteresis	Battery charging and battery / NTC temperature decreasing		30		mV
BATTERY CHARGER THERMAL REGULATION						
$T_{J(REG_LOWER)}$	Charger lower thermal regulation limit			75		°C
$T_{J(REG_UPPER)}$	Charger upper thermal regulation limit			95		°C
$T_{J(OFF)}$	Charger thermal shutdown temperature			105		°C
$T_{J(OFF-HYS)}$	Charger thermal shutdown hysteresis			20		°C
LDO						
$I_{MAX(LDO)}$	Maximum LDO output current, $V_{VLDO} = 2.2$ V	$V_{SYS} = 4.2$ V $V_{VIN} = 0$ V $VLDO_SET = 0$ V		30		mA
	Maximum LDO output current, $V_{VLDO} = 3.0$ V	$V_{SYS} = 4.2$ V $V_{VIN} = 0$ V $VLDO_SET = V_{SYS}$		30		mA
$I_{SC(LDO)}$	Short circuit current limit		30		100	mA
V_{VLDO}	LDO output voltage	$VLDO_SET = LOW$ ($VLDO_SET$ pin connected to DGND) 3.7 V $\leq V_{VIN} \leq 6.5$ V $I_{LOAD(LDO)} = -10$ mA	2.13	2.2	2.27	V
V_{VLDO}	LDO output voltage	$VLDO_SET = HIGH$ ($V_{VLDO_SET} = V_{SYS}$) 3.7 V $\leq V_{VIN} \leq 6.5$ V $I_{LOAD(LDO)} = -10$ mA	2.91	3.0	3.09	V
$V_{DO(LDO)}$	LDO Dropout voltage	$V_{VIN} - V_{LDO}$ when in dropout $I_{LOAD(LDO)} = -10$ mA			200	mV
	Line regulation	3.7 V $\leq V_{VIN} \leq 6.5$ V $I_{LOAD(LDO)} = -10$ mA	-1		1	%
	Load regulation	$V_{VIN} = 3.5$ V 0.1 mA $\leq I_{LOAD(LDO)} \leq -10$ mA	-2		2	%
PSRR	Power supply rejection ratio	@20 KHz, $I_{LOAD(LDO)} = 10$ mA $V_{DO(LDO)} = 0.5$ V $C_{VLDO} = 10$ μ F		45		dB
BOOST CONVERTER						
$I_{Q(BST)}$	Boost operating quiescent current	Boost Enabled, $BST_EN = High$ $I_{OUT(BST)} = 0$ mA (boost is not switching) $V_{BAT} = 3.6$ V		2	4.5	μ A
$R_{DS(on)(BST)}$	Boost MOSFET switch on-resistance	$V_{IN(BST)} = 2.5$ V $I_{SW(MAIN)} = 200$ mA		0.8	1.2	Ω

Electrical Characteristics (continued)

over operating free-air temperature range (unless otherwise noted)

PARAMETER		TEST CONDITIONS	MIN	TYP	MAX	UNIT
$I_{LKG(BST_SW)}$	Leakage into BST_SW pin (includes leakage into analog h-bridge switches)	BST_EN signal = LOW (Boost disabled) $V_{BST_SW} = 4.2\text{ V}$ No load on BST_OUT pin			90	nA
$I_{SWLIM(BST)}$	Boost MOSFET switch current limit		100	150	200	mA
$V_{DIODE(BST)}$	Voltage across integrated boost diode during normal operation	BST_EN signal = HIGH $V_{BST_SW} = 16.0\text{ V}$ $I_{BST_OUT} = -2\text{ mA}$			1.0	V
$V_{REF(BST)}$	Boost reference voltage on BST_FB pin		1.17	1.2	1.23	V
$V_{REFHYS(BST)}$	Boost reference voltage hysteresis on BST_FB pin		2	2.5	3.2	%
$T_{ON(BST)}$	Maximum on time detection threshold		5	6.5	8	μs
$T_{OFF(BST)}$	Minimum off time detection threshold		1.4	1.75	2.1	μs
$T_{SHUT(BST)}$	Boost thermal shutdown threshold			105		$^{\circ}\text{C}$
$T_{SHUT-HYS(BST)}$	Boost thermal shutdown threshold hysteresis			20		$^{\circ}\text{C}$
FULL H-BRIDGE ANALOG SWITCHES						
$I_{Q(HSW)}$	Operating quiescent current for h-bridge switches				5	μA
$R_{DS(on)(HSW)}$	H-bridge switches on resistance			20	40	Ω
$T_{DELAY(HSW-H)}$	H-bridge switch propagation delay, input switched from low to high state.	$V_{HBxy} = 0\text{ V} \rightarrow V_{VLDO}$		100		ns
$T_{DELAY(HSW-L)}$	H-bridge switch propagation delay, input switched from high to low state.	$V_{HBxy} = V_{VLDO} \rightarrow 0\text{ V}$		100		ns
POWER MANAGEMENT CORE CONTROLLER						
$V_{IL(PMIC)}$	Low logic level for logic signals on power management core (BST_EN, CHG_EN, SLEEP, HBR1, HBR2, HBL1, HBL2)	IO logic level decreasing: $V_{SYS} \rightarrow 0\text{ V}$ $I_{IN} = 1\text{ mA}$			0.4	V
$V_{IH(PMIC)}$	High logic level for signals on power management core (BST_EN, CHG_EN, SLEEP, HBR1, HBR2, HBL1, HBL2)	IO logic level increasing: $0\text{ V} \rightarrow V_{SYS}$ $I_{IN} = 1\text{ mA}$	1.2			V
$V_{GOOD(LDO)}$	Power fault detection threshold	V_{VLDO} decreasing			1.96	V
$V_{GOOD_HYS(LDO)}$	Power fault detection hysteresis	V_{VLDO} increasing		50		mV
$V_{BATCOMP}$	COMP pin voltage (scaled down battery voltage)	$V_{BAT} = 4.2\text{ V}$ $V_{VLDO} = 2.2\text{ V}$		1.85		V
		$V_{BAT} = 2.5\text{ V}$ $V_{VLDO} = 2.2\text{ V}$		1.10		V
		$V_{BAT} = 4.2\text{ V}$ $V_{VLDO} = 3.0\text{ V}$		1.90		V
		$V_{BAT} = 3.3\text{ V}$ $V_{VLDO} = 3.0\text{ V}$		1.50		V

2.6 System Operation

The system must complete the power up routine before it enters normal operating mode. The specific system operation depends on the setting defined by the state of the SW_SEL pin. The details of the system operation for each configuration of the SW_SEL pin are contained in this section.

2.6.1 System Power Up

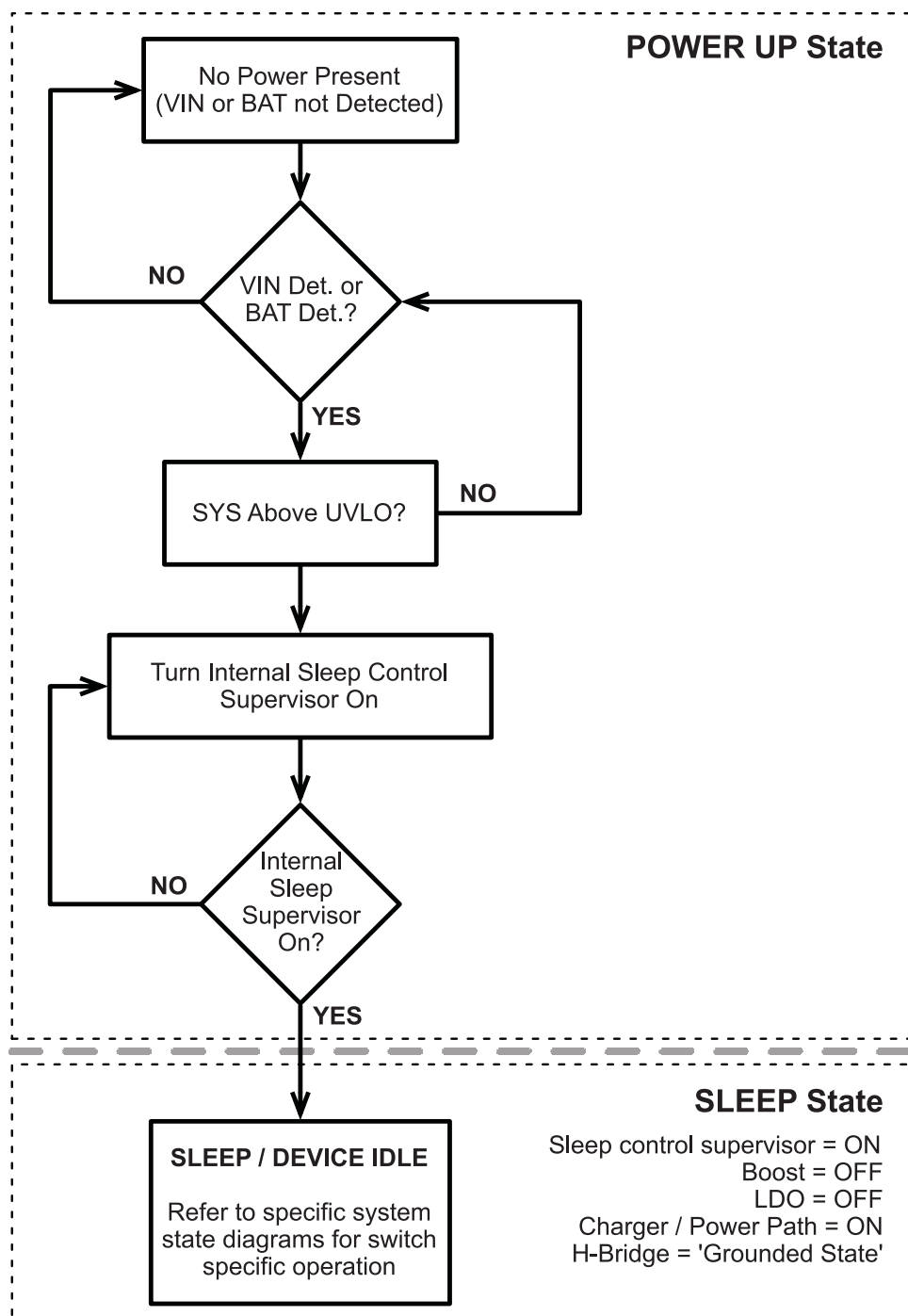

Figure 2-1. System Power Up State Diagram

2.6.2 System Operation Using Push Button Switch

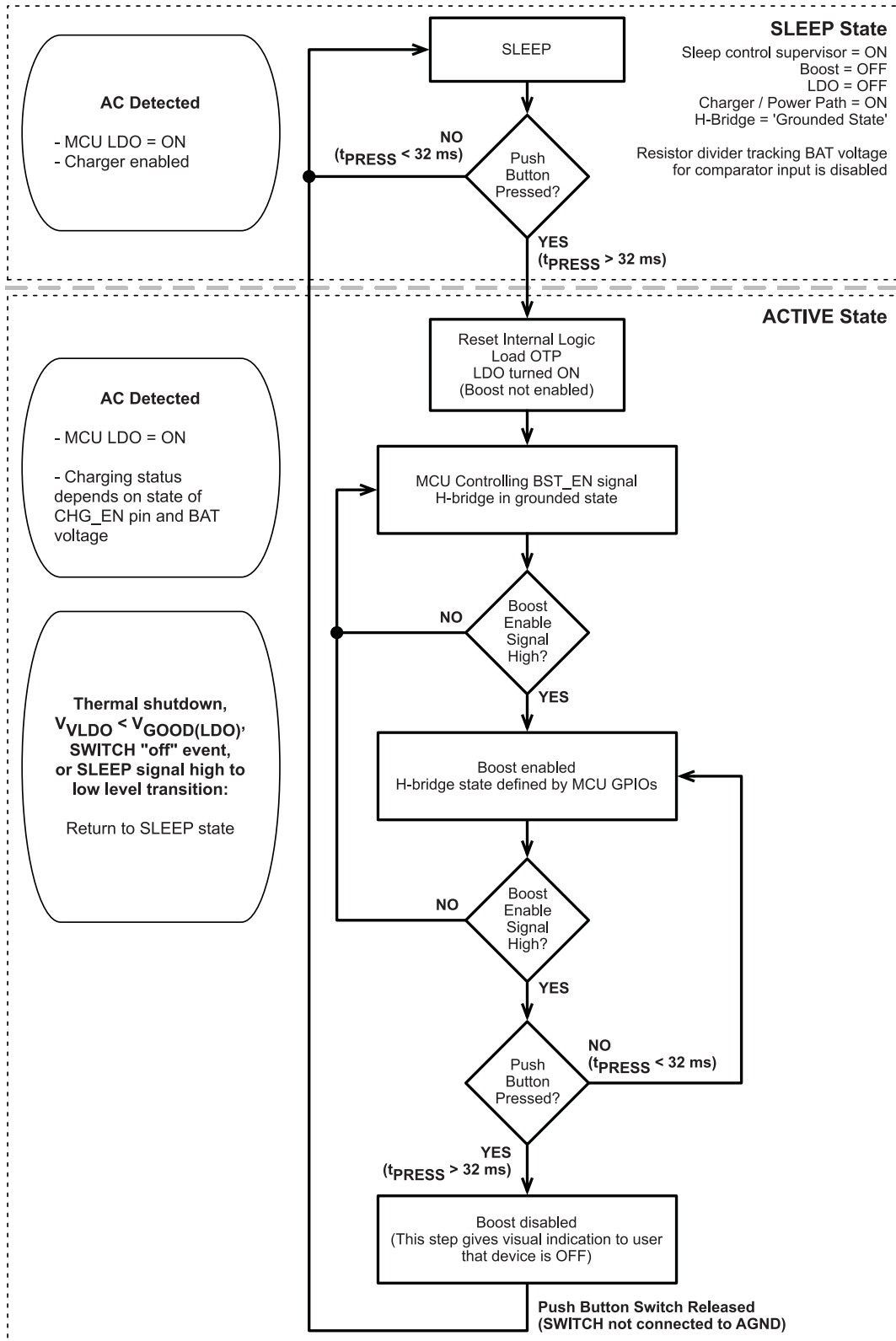

Figure 2-2. Push Button State Diagram

2.6.3 System Operation Using Slider Switch

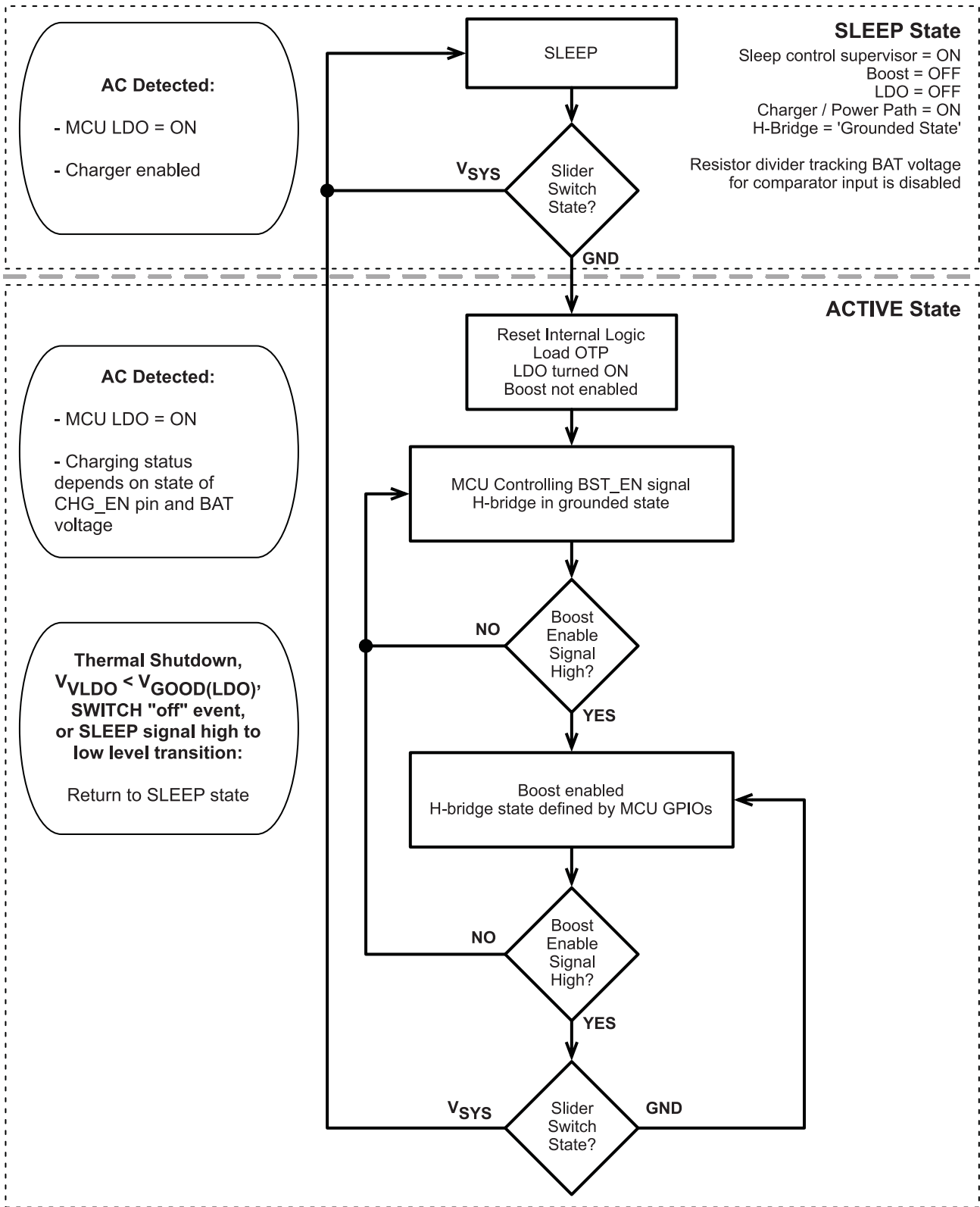

Figure 2-3. System Operation Using Slider Switch

2.7 Linear Charger Operation

This device has an integrated Li-Ion battery charger and system power path management feature targeted at space-limited portable applications. The architecture powers the system while simultaneously and independently charging the battery. This feature reduces the number of charge and discharge cycles on the battery, allows for proper charge termination, and enables the system to run with a defective or absent battery pack. It also allows instant system turn-on even with a totally discharged battery.

The input power source for charging the battery and running the system can be an AC adapter or USB port connected to the VIN pin as long as the input meets the device operating conditions outlined in this datasheet. The power-path management feature automatically reduces the charging current if the system load increases. Note that the charger input, VIN, has voltage protection up to 28 V.

2.7.1 Battery and TS Detection

To detect and determine between a good or damaged battery, the device checks for a short circuit on the BAT pin by sourcing $I_{BAT(SC)}$ to the battery and monitoring the voltage on the BAT pin. While sourcing this current if the BAT pin voltage exceeds $V_{BAT(SC)}$, a battery has been detected. If the voltage stays below the $V_{BAT(SC)}$ level, the battery is presumed to be damaged and not safe to charge.

The device will also check for the presence of a 10 k Ω NTC thermistor attached to the TS pin of the device. The check for the NTC thermistor on the TS pin is done much like the battery detection feature described previously. The voltage on the TS pin is compared against a defined level and if it is found to be above the threshold, the NTC thermistor is assumed to be disconnected or not used in the system. To reduce the system quiescent current, the NTC thermistor temperature sensing function is only enabled when the device is charging and when the thermistor has been detected.

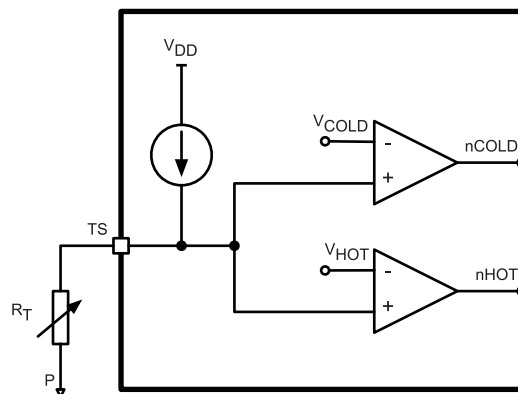

Figure 2-4. Thermistor Detection and Circuit

2.7.2 Battery Charging

The battery is charged in three phases: conditioning pre-charge, constant-current fast charge (current regulation), and a constant-voltage tapering (voltage regulation). In all charge phases, an internal control loop monitors the IC junction temperature and reduces the charge current if an internal temperature threshold is exceeded. [Figure 2-5](#) shows what happens in each of the three charge phases:

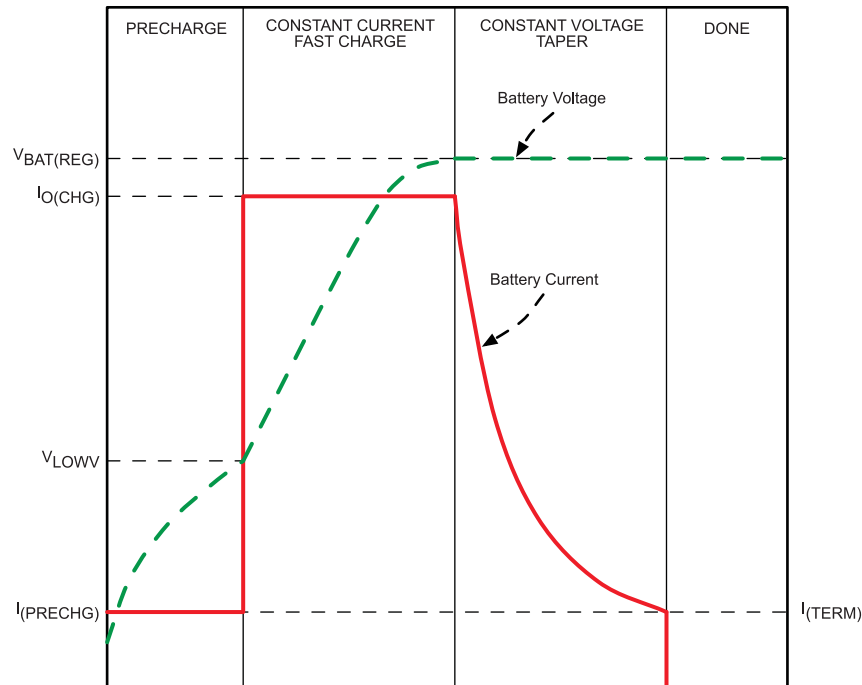

Figure 2-5. Battery Charge Phases

In the pre-charge phase, the battery is charged with the pre-charge current that is scaled to be 10% of the fast-charge current set by the resistor connected to the ISET pin. Once the battery voltage crosses the V_{LOWV} threshold, the battery is charged with the fast-charge current (I_{CHG}). As the battery voltage reaches $V_{BAT(REG)}$, the battery is held at a constant voltage of $V_{BAT(REG)}$ and the charge current tapers off as the battery approaches full charge. When the battery current reaches I_{TERM} , the charger indicates charging is done by making the nCHG_STAT pin high impedance. Note that termination detection is disabled whenever the charge rate is reduced from the set point because of the actions of the thermal loop, the DPM loop, or the $V_{IN(LOWV)}$ loop.

2.7.2.1 Pre-charge

The value for the pre-charge current is set to be 10% of the charge current that is set by the external resistor, R_{ISET} . Pre-charge current is scaled to lower currents when the charger is in thermal regulation.

2.7.2.2 Charge Termination

In the fast charge state, once $V_{BAT} \geq V_{BAT(REG)}$, the charger enters constant voltage mode. In constant voltage mode, the charge current will taper until termination when the charge current falls below the $I_{(TERM)}$ threshold (typically 10% of the programmed fast charge current). Termination current is not scaled when the charger is in thermal regulation. When the charging is terminated, the nCHG_STAT pin will be high impedance (effectively turning off any LED that is connected to this pin).

2.7.2.3 Recharge

Once a charge cycle is complete and termination is reached, the battery voltage is monitored. If $V_{BAT} < V_{BAT(REG)} - V_{RCH}$, the device determines if the battery has been removed. If the battery is still present, then the recharge cycle begins and will end when $V_{BAT} \geq V_{BAT(REG)}$.

2.7.2.4 Charge Timers

The charger in this device has internal safety timers for the pre-charge and fast charge phases to prevent potential damage to either the battery or the system. The default values for these timers are found as follows: Pre-charge timer = 0.5 hours (30 minutes) and Fast charge timer = 5 hours (300 minutes).

During the fast charge phase, the following events may increase the timer durations:

1. The system load current activates the DPM loop which reduces the available charging current
2. The input current is reduced because the input voltage has fallen to $V_{IN(Low)}$
3. The device has entered thermal regulation because the IC junction temperature has exceeded $T_{J(REG)}$

During each of these events, the internal timers are slowed down proportionately to the reduction in charging current.

If the pre-charge timer expires before the battery voltage reaches V_{LOWV} , the charger indicates a fault condition.

2.7.3 Charger Status (nCHG_STAT Pin)

The nCHG_STAT pin is used to indicate the charger status by an externally connected resistor and LED circuit. The pin is an open drain input and the internal switch is controlled by the logic inside of the charger. This pin may also be connected to a GPIO of the system MCU to indicate charging status. The table below details the status of the nCHG_STAT pin for various operating states of the charger.

Table 2-1. nCHG_STAT Functionality

Charging Status	nCHG_STAT FET / LED
Pre-charge / Fast Charge / Charge Termination	ON
Recharge	OFF
OVP	OFF
SLEEP	OFF

2.8 LDO Operation

The power management core has a low dropout linear regulator (LDO) with variable output voltage capability. This LDO is used for supplying the microcontroller and may be used to supply either an external IR or RF module, depending on system requirements. The LDO can supply a continuous current of up to 30 mA.

The output voltage (V_{VLDO}) of the LDO is set by the state of the VLDO_SET pin. See [Table 2-2](#) for details on setting the LDO output voltage.

Table 2-2. VLDO_SET Functionality

VLDO_SET State	VLDO Output Voltage (V_{VLDO})
Low ($VLDO_SET < V_{IL(PMIC)}$)	2.2 V
High ($VLDO_SET > V_{IH(PMIC)}$)	3.0 V

2.8.1 LDO Internal Current Limit

The internal current limit feature helps to protect the LDO regulator during fault conditions. During current limit, the output sources a fixed amount of current that is defined in the electrical specification table. The voltage on the output in this stage can not be regulated and will be $V_{OUT} = I_{LIMIT} \times R_{LOAD}$. The pass transistor integrated into the LDO will dissipate power, $(V_{IN} - V_{OUT}) \times I_{LIMIT}$, until the device enters thermal shutdown. In thermal shutdown the device will enter the "SLEEP / POWER OFF" state which means that the LDO will then be disabled and shut off.

2.9 Boost Converter Operation

The boost converter in this device is designed for the load of active shutter 3D glasses. This load is typically a light load where the average current is 2 mA or lower and the peak current out of a battery is limited in operation. This asynchronous boost converter operates with a minimum off time / maximum on time for the integrated low side switch, these values are specified in the electrical characteristics table of this datasheet.

The peak output voltage from the boost converter is adjustable and set by using an external resistor divider connected between BST_OUT, the BST_FB pin, and ground. The peak output voltage is set by choosing resistors for the feedback network such that the voltage on the BST_FB pin is $V_{REF(BST)} = 1.2\text{ V}$. See Section 3.3 for more information on calculating resistance values for this feedback network.

The efficiency curves for various input voltages over the typical 3D glasses load range (2 mA and lower) are shown below. All curves are for a target V_{OUT} of 16 V. For output voltages less than 16 V, a higher efficiency at each operating input voltage should be expected. Note that efficiency is dependent upon the external boost feedback network resistances, the inductor used, and the type of load connected.

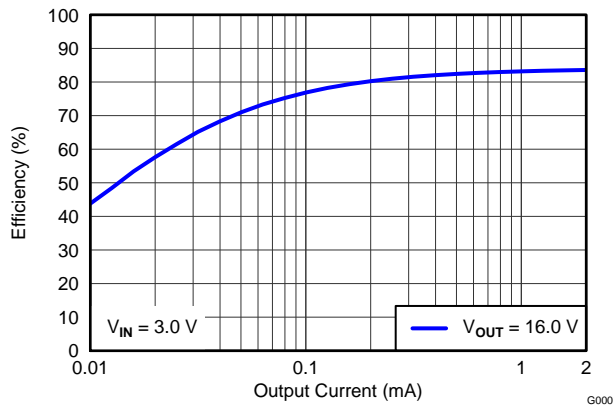

Figure 2-6. Boost Efficiency vs. I_{OUT} , $V_{IN} = 3.0\text{ V}$, $V_{OUT} = 16\text{ V}$

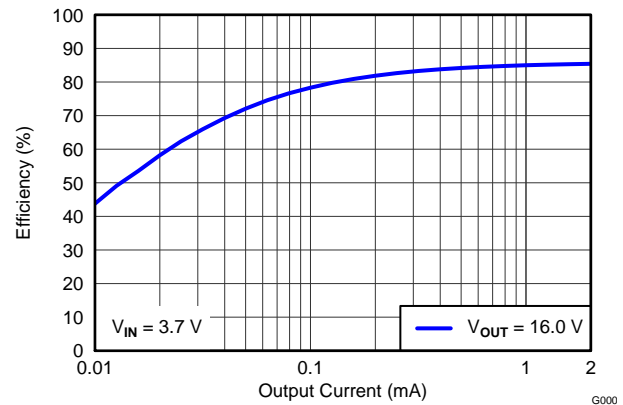

Figure 2-7. Boost Efficiency vs. I_{OUT} , $V_{IN} = 3.7\text{ V}$, $V_{OUT} = 16\text{ V}$

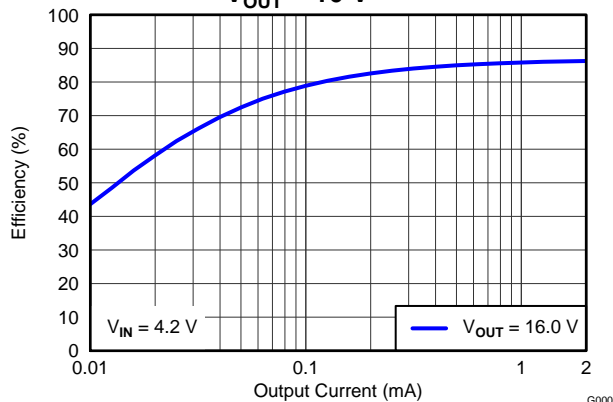

Figure 2-8. Boost Efficiency vs. I_{OUT} , $V_{IN} = 4.2\text{ V}$, $V_{OUT} = 16\text{ V}$

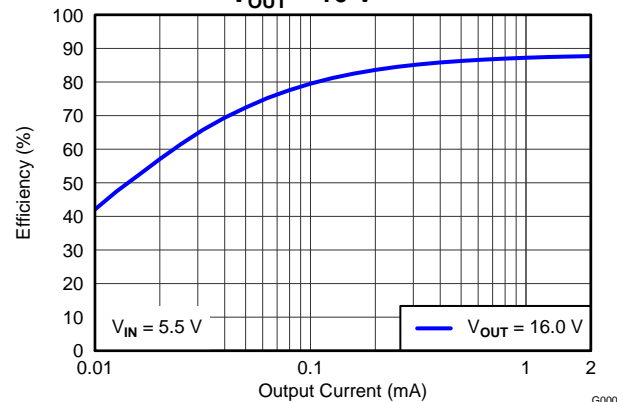

Figure 2-9. Boost Efficiency vs. I_{OUT} , $V_{IN} = 5.5\text{ V}$, $V_{OUT} = 16\text{ V}$

2.9.1 Boost Thermal Shutdown

An internal thermal shutdown mode is implemented in the boost converter that shuts down the device if the typical junction temperature of 105°C is exceeded. If the device is in thermal shutdown mode, the main switch of the boost is open and the device enters the "SLEEP / POWER OFF" state.

2.9.2 Boost Load Disconnect

When the boost is disabled (BST_EN = LOW), the H-bridge is automatically placed into the OFF state. In the OFF state the high side H-bridge switches are open and the low side switches of the H-bridge are closed. The OFF state grounds and discharges the load, potentially prolonging the life of the LC shutters by eliminating any DC content (see Section 2.10.1 for more information regarding the H-bridge states). The disconnection of the load is done with the H-Bridge and can be seen in the next figure (Figure 2-10).

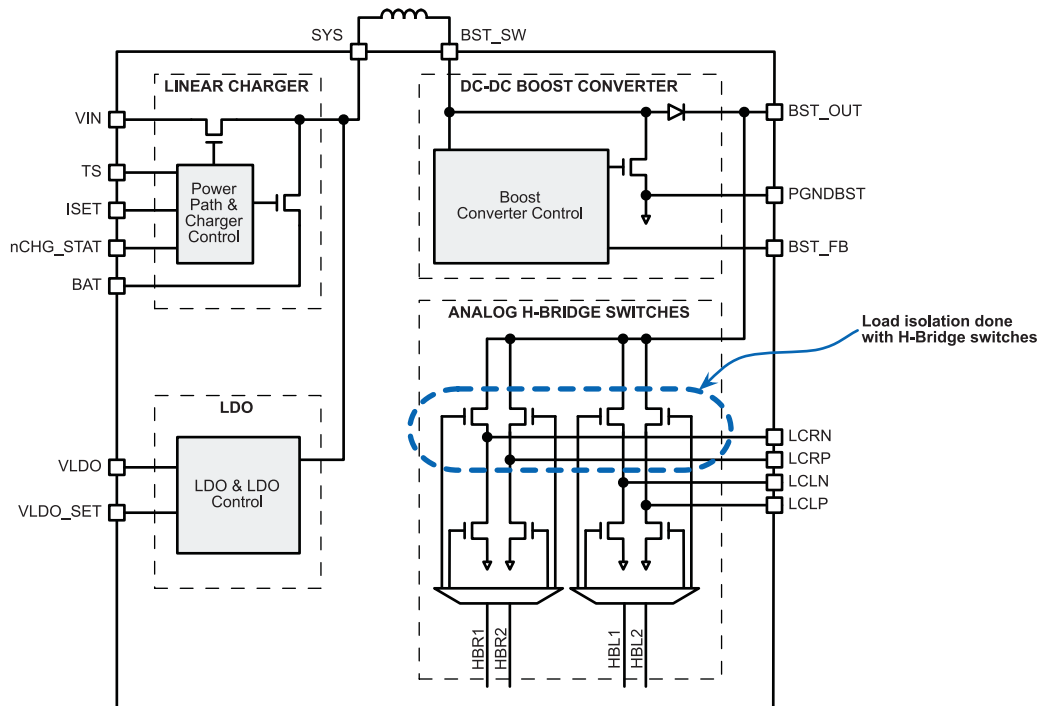

Figure 2-10. Boost Load Disconnect

An advantage to this topology for disconnecting the load is that the boost output capacitor is charged to approximately the SYS voltage level, specifically $V_{SYS} - V_{DIODE(BST)}$, when the boost is disabled. This design ensures that there is not a large in-rush current into the boost output capacitor when the boost is enabled. The boost operation efficiency is also increased because there is no load disconnect switch in the boost output path, such a switch would decrease efficiency because of the resistance that it would introduce.

2.10 Full H-Bridge Analog Switches

The TPS65735 has two integrated full H-bridge analog switches that can be connected to GPIOs of a host microcontroller. There is an internal level shifter that takes care of the input signals to the H-Bridge switches.

2.10.1 H-Bridge Switch Control

The H-Bridge switches are controlled by an external microcontroller for system operation - specifically to control charge polarity on the LCD shutters. Depending on the state of the signals from the microcontroller, the H-Bridge will be put into 4 different states. These states are:

- **OPEN:** All Switches Opened
- **CHARGE+:** Boost Output Voltage Present on Pins LCLP or LCRP
- **CHARGE-:** Boost Output Voltage Present on Pins LCLN or LCRN
- **GROUNDED:** High side switches are opened and low side switches are closed

If CHARGE+ state is followed by the CHARGE- state, the voltage across the capacitor connected to the H-Bridge output terminals will be reversed. The system is automatically put into the GROUNDED state when the boost is disabled by the BST_EN pin - for more details see [Section 2.6](#).

Table 2-3. H-Bridge States from Inputs

HBx2 [HBL2 & HBR2]	HBx1 [HBL1 & HBR1]	H-Bridge State
0	0	OPEN
0	1	CHARGE +
1	0	CHARGE -
1	1	GROUNDED

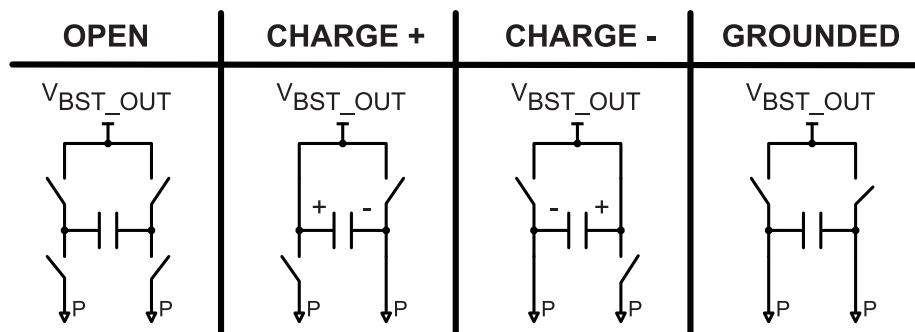

Figure 2-11. H-Bridge States

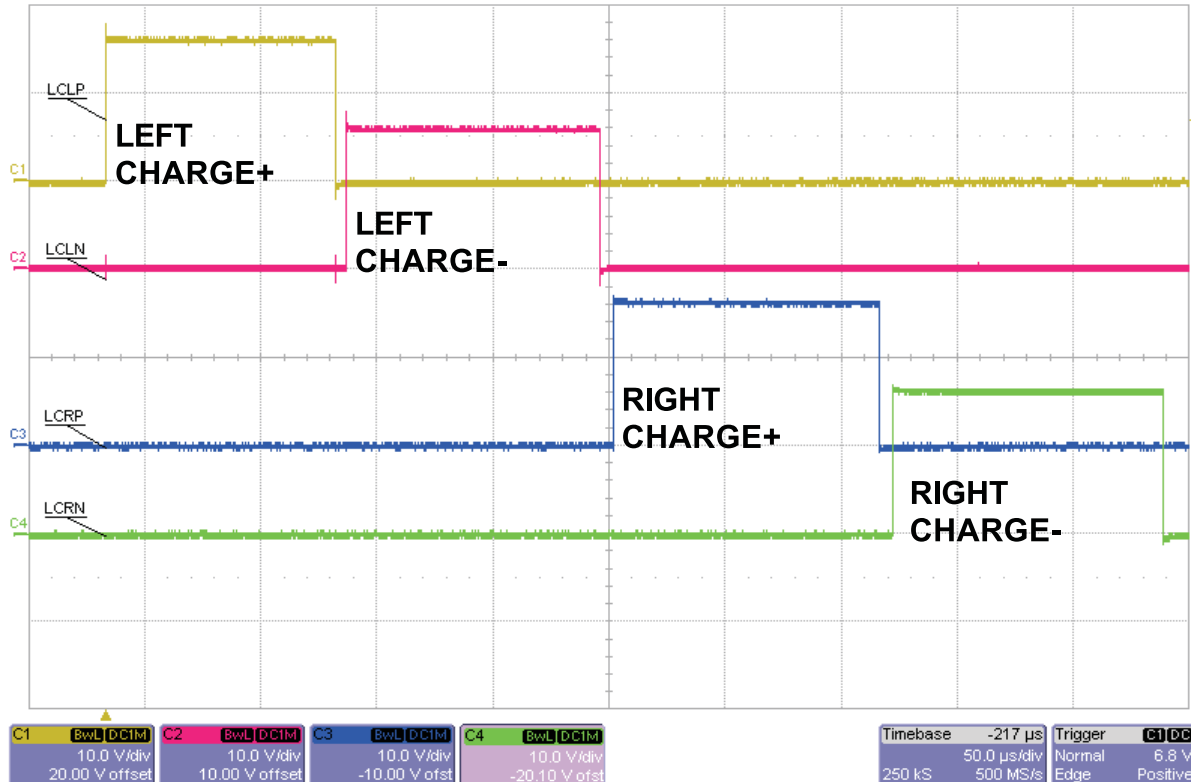

Figure 2-12. H-Bridge States from Oscilloscope

2.11 Power Management Core Control

Various functions of the power management core can be controlled by GPIOs of an external MCU or by setting the default state by connecting these function pins to a logic high or low level on the PCB.

2.11.1 SLEEP / Power Control Pin Function

The internal SLEEP signal between the power management device and the MSP430 can be used to control the power down behavior of the device. This has multiple practical applications such as a watchdog implementation for the communication between the sender (TV) and the 3D glasses (receiver) or different required system on and off times; typically when the push-button press timing for an off event is a few seconds in length, programmable by software in the system MCU.

If there is a requirement that the push-button press for system on and off events are different, the SLEEP signal must be set to a logic high value ($V_{SLEEP} > V_{IH(PMIC)}$) upon system startup. This implementation allows the device to power down the system on the falling edge of the SLEEP signal (when: $V_{SLEEP} < V_{IL(PMIC)}$).

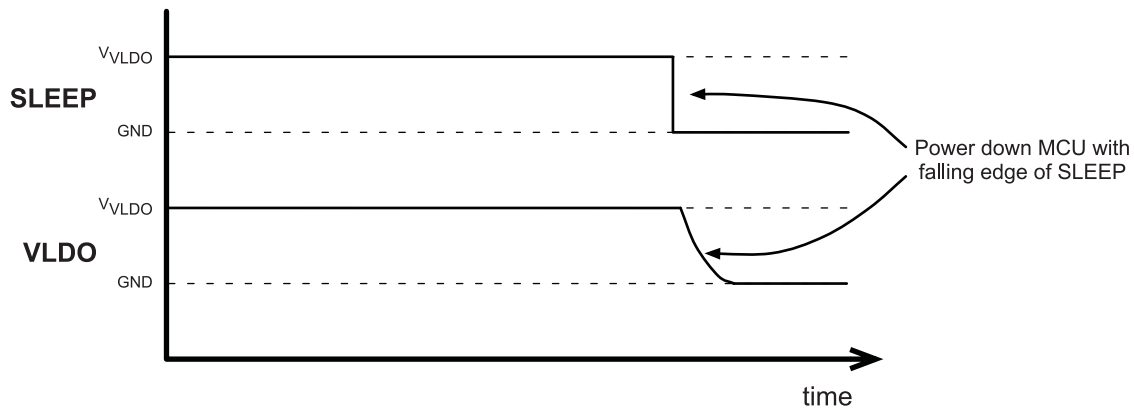

Figure 2-13. SLEEP Signal to Force System Power Off

2.11.2 COMP Pin Functionality

The COMP pin is used to output a scaled down voltage level related to the battery voltage for input to a comparator of a microcontroller. Applications for this COMP feature could be to generate an interrupt on the microcontroller when battery voltage drops under a threshold and the device can then be shut down or indicate to the end user with an LED that the battery requires charging.

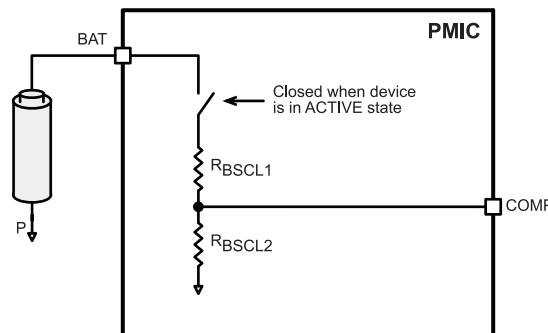

Figure 2-14. COMP Pin Internal Connection

Table 2-4. Scaling Resistors for COMP Pin Function
($V_{VLDO} = 2.2\text{ V}$)

Scaling Resistors for COMP Pin Function	Value
R_{BSCL1}	3.0 M Ω
R_{BSCL2}	2.36 M Ω

Table 2-5. Scaling Resistors for COMP Pin Function
($V_{VLDO} = 3.0\text{ V}$)

Scaling Resistors for COMP Pin Function	Value
R_{BSCL1}	3.0 M Ω
R_{BSCL2}	2.48 M Ω

Using the designed values in [Table 2-4](#) or [Table 2-5](#), the voltage on the COMP pin will be: $V_{COMP} = 0.5 \times V_{VLDO} + 300\text{ mV}$. This assures that the COMP pin voltage will be close to half of the LDO output voltage plus the LDO dropout voltage of the device. The COMP pin can also be used as the input to an ADC channel of an external microcontroller if greater accuracy or more functionality is desired than a simple comparison.

2.11.3 SW_SEL Pin Functionality

The SW_SEL pin is used to select what type of switch is connected to the SWITCH pin of the device. Selection between a push-button and a slider switch can be made based on the state of this pin.

Table 2-6. SW_SEL Settings

SW_SEL State	Type of Switch Selected
Low ($V_{SW_SEL} < V_{IL(PMIC)}$)	Slider Switch
High ($V_{SW_SEL} > V_{IH(PMIC)}$)	Push-button

When the push button switch type is selected, the device will debounce the SWITCH input with a 32 ms timer for both the ON and OFF events and either power on or off the device. Using the push-button switch function, the on and off timings are equal; $t_{ON} = t_{OFF}$. If the system requirements are such that the on and off timings should be different, $t_{ON} \neq t_{OFF}$, then refer to the following section for the correct system setup: [Section 3.4](#). When the slider switch operation is selected, the SWITCH pin must be externally pulled up to the SYS voltage with a resistor and the output connected to the slider switch. When the SWITCH pin is pulled to ground, the device will turn on and enter the power up sequence.

2.11.4 SWITCH Pin

The SWITCH pin behavior is defined by the SW_SEL pin ([Section 2.11.3](#)) which defines the type of switch that is connected to the system; either a slider switch or push-button.

2.11.5 Slider Switch Behavior

If a slider switch is connected in the system then the system power state and VLDO output (which can power an external MCU) is defined by the state of the slider switch. If the slider is in the "off" position than the SWITCH pin should be connected to the SYS pin. If the slider is in the "on" position than the SWITCH pin should be connected to ground. [Figure 2-15](#) details the system operation using the slider switch configuration.

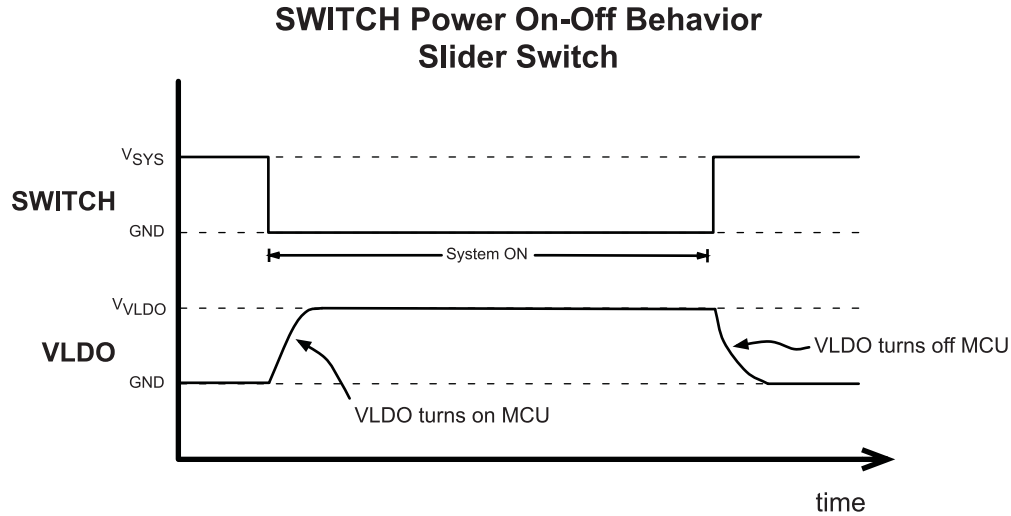

Figure 2-15. SWITCH, Slider Power On-Off Behavior

2.11.6 Push-Button Switch Behavior

The system is powered on or off by a push-button press after a press that is greater than 32 ms. The following figures (Figure 2-16 and Figure 2-17) show the system behavior and the expected VLDO output during the normal push-button operation where the on and off press timings are the same value, $t_{ON} = t_{OFF}$.

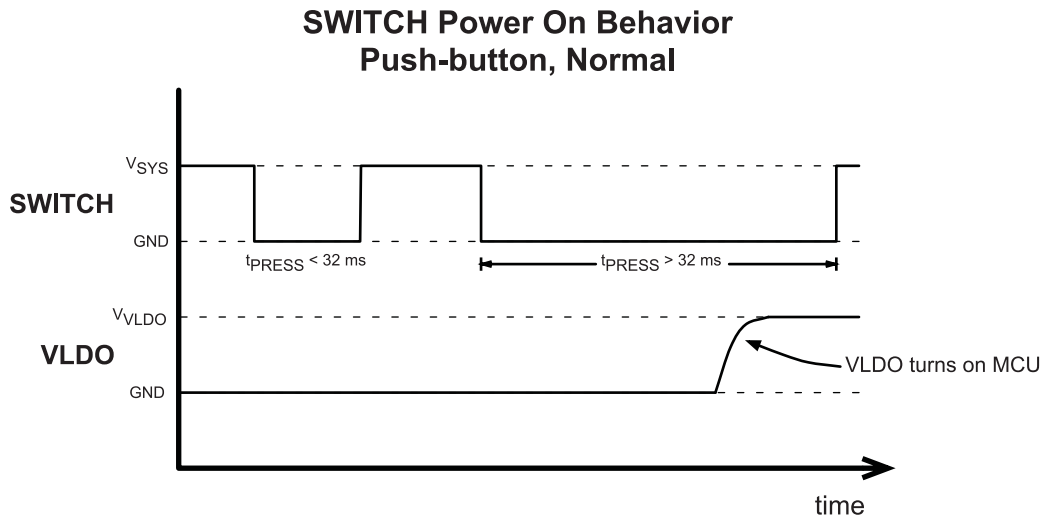

Figure 2-16. SWITCH, Push-button Power On Behavior

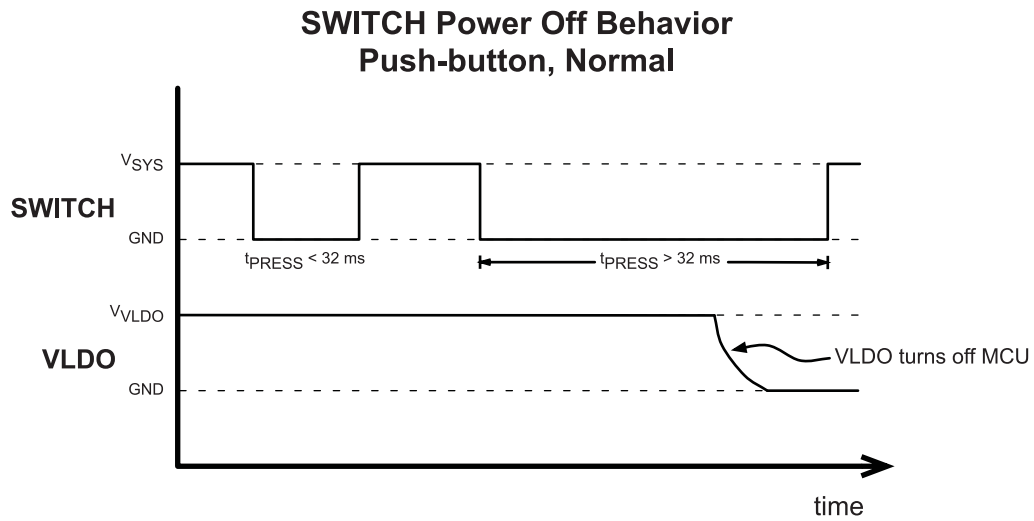

Figure 2-17. SWITCH, Push-button Power Off Behavior

3 APPLICATION INFORMATION

3.1 Applications Schematic

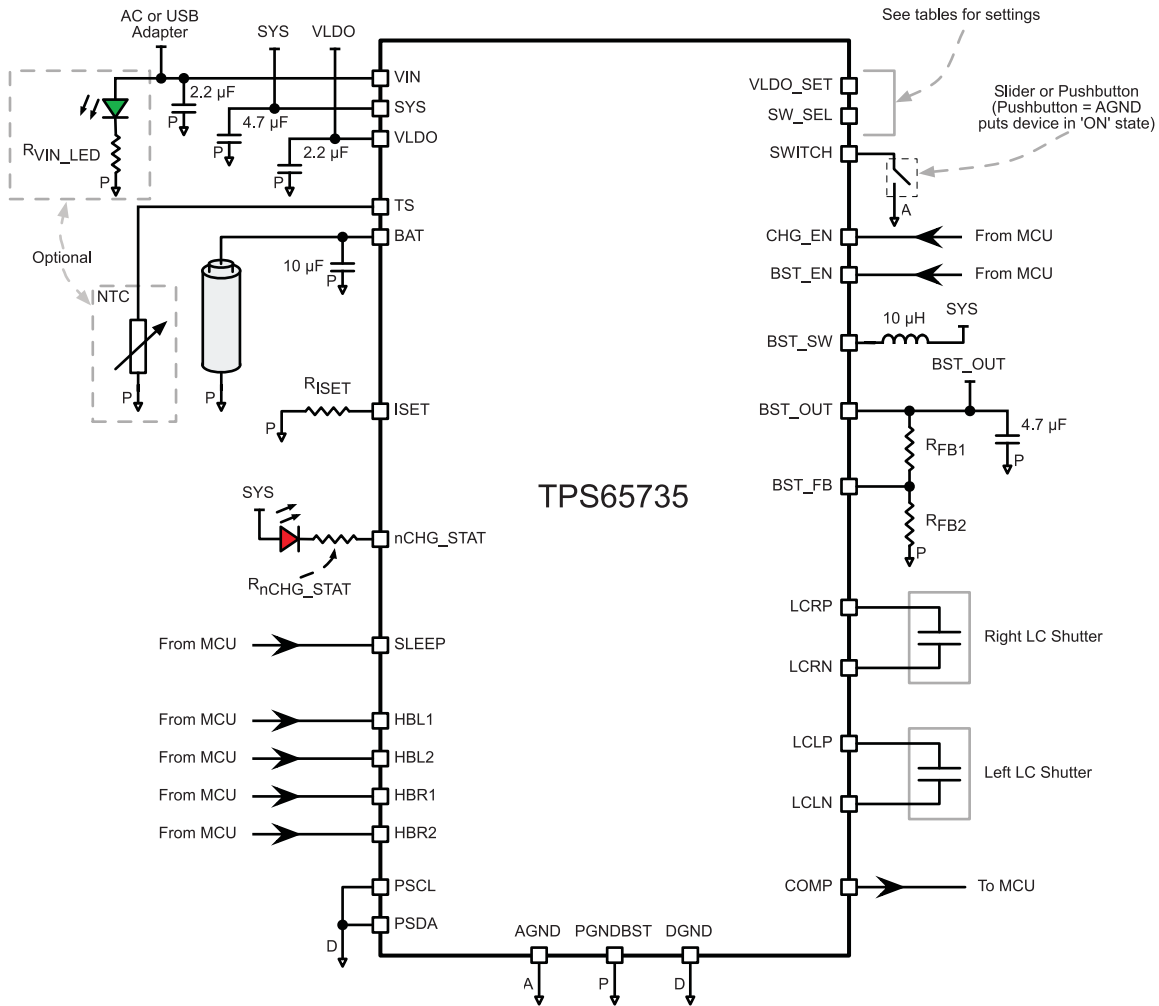

Figure 3-1. TPS65735 Applications Schematic

3.2 Reducing System Quiescent Current (I_Q)

This PMU device has been optimized for low power applications. If an even lower quiescent current is desired, the following circuit and configuration can be utilized to reduce system off / sleep quiescent current further. Please note that this will cause a slight efficiency drop to the overall system due to the addition of the resistance of the FET that has been added. With this circuit, achieving an I_Q of less than 1 μA is possible. Please refer to the datasheet of the MCU used in the system to determine the system I_Q that is possible.

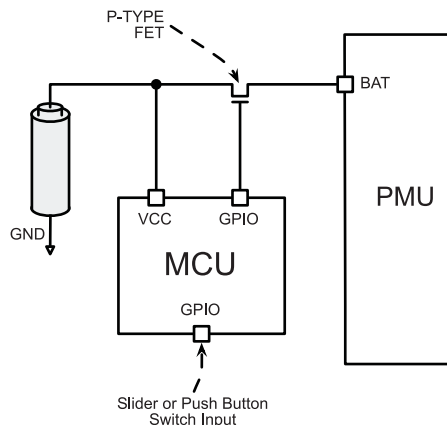

Figure 3-2. Reducing System I_q with Addition of a FET

Along with this system configuration, the MCU code must be written such that the MCU sits in the lowest power state that can support an interrupt on a GPIO from a switch (slider or push button). After a valid button press or switch action, the device can begin the power on sequence and open the FET in the previous figure (Figure 3-2). This will allow power flow into the PMU and the system can then operate normally.

3.3 Boost Converter Application Information

3.3.1 Setting Boost Output Voltage

To set the boost converter output voltage of this device, two external resistors that form a feedback network are required. The values recommended below (in Table 3-1) are given for a desired quiescent current of 5 μA when the boost is enabled and switching. See Figure 3-3 for the detail of the applications schematic that shows the boost feedback network and the resistor names used in the table below.

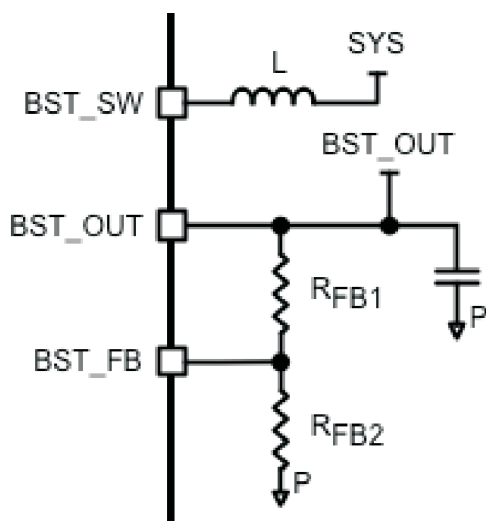

Figure 3-3. Boost Feedback Network Schematic

Table 3-1. Recommended R_{FB1} and R_{FB2} Values (for $I_{Q(FB)} = 5 \mu A$)

Targeted V_{BST_OUT}	$R_{FB1}^{(1)}$	$R_{FB2}^{(1)}$
8 V	1.3 M Ω	240 k Ω
10 V	1.8 M Ω	240 k Ω
12 V	2.2 M Ω	240 k Ω
14 V	2.4 M Ω	240 k Ω
16 V	3.0 M Ω	240 k Ω

(1) Resistance values given in closest standard value (5% tolerance, E24 grouping).

These resistance values can also be calculated using the following information. To start, it is helpful to target a quiescent current through the boost feedback network while the device is operating ($I_{Q(FB)}$). When the boost output voltage and this targeted quiescent current is known, the total feedback network resistance can be found.

The value for R_{FB2} can be found by using the boost feedback pin voltage ($V_{FB} = 1.2$ V, see "Electrical Characteristics" in [Section 2](#)) and $I_{Q(FB)}$ in the following equation:

$$R_{FB1} + R_{FB2} = V_{BST_OUT} / I_{Q(FB)}$$

$$R_{FB2} = (1.2 \text{ V}) / I_{Q(FB)}$$

To find R_{FB1} , simply subtract the R_{FB2} from $R_{FB(TOT)}$:

$$R_{FB1} = R_{FB(TOT)} - R_{FB2}$$

3.3.2 Boost Inductor Selection

The selection of the boost inductor and output capacitor is very important to the performance of the boost converter. The boost has been designed for optimized operation when a 10 μH inductor is used. Smaller inductors, down to 4.7 μH , may be used but there will be a slight loss in overall operating efficiency. A few inductors that have been tested and found to give good performance can be found in the list below:

Recommended 10 μH inductors

- TDK VLS201612ET-100M (10 μH , $I_{MAX} = 0.53$ A, $R_{DC} = 0.85 \Omega$)
- Taiyo Yuden CBC2016B100M (10 μH , $I_{MAX} = 0.41$ A, $R_{DC} = 0.82 \Omega$)

3.3.3 Boost Capacitor Selection

The recommended minimum value for the capacitor on the boost output, BST_OUT pin, is 4.7 μF . Values that are larger can be used with the measurable impact being a slight reduction in the boost converter output voltage ripple while values smaller than this will result in an increased boost output voltage ripple. Note that the voltage rating of the capacitor should be sized for the maximum expected voltage at the BST_OUT pin.

3.4 Bypassing Default Push-Button SWITCH Functionality

If the SWITCH pin functionality is not required to power on and off the device because of different system requirements (when the SWITCH timing requirements of system will be controlled by an external microcontroller), then the feature can be bypassed. The following diagram shows the connections required for this configuration, note that INT. I/O refers to an interruptible I/O on the microcontroller.

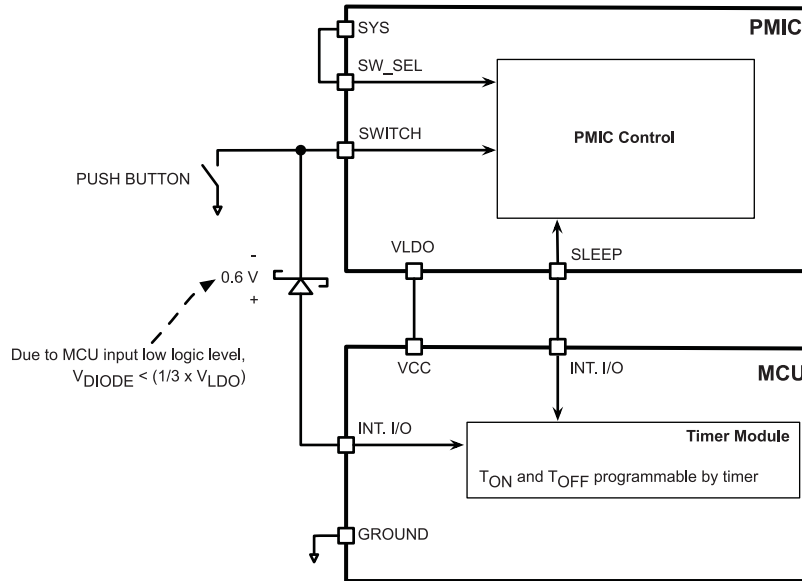

Figure 3-4. Bypassing Default TPS65735 Push Button SWITCH Timing

In a system where a different push-button SWITCH off timing is required, the SLEEP pin is used to control the power off of the device. After system power up, the MCU must force the SLEEP pin to a high state ($V_{SLEEP} > V_{IH(PMIC)}$). Once the SWITCH push-button is pressed to shut the system down, a timer in the MCU should be active and counting the desired t_{OFF} time of the device. Once this t_{OFF} time is detected, the MCU can assert the SLEEP signal to a logic low level ($V_{SLEEP} < V_{IL(PMIC)}$). It is on the falling edge of the SLEEP signal where the system will be powered off (see Figure 3-5)

SWITCH Power Off Behavior SLEEP Controlling Off

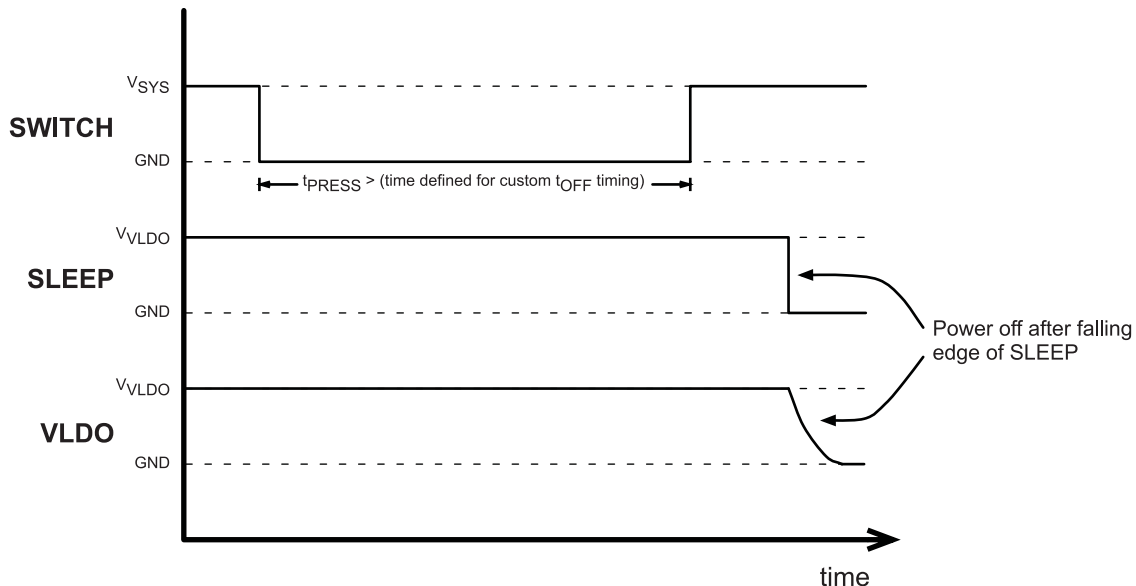

Figure 3-5. SWITCH Press and SLEEP Signal to Control System Power Off

PACKAGING INFORMATION

Orderable Device	Status (1)	Package Type	Package Drawing	Pins	Package Qty	Eco Plan (2)	Lead/Ball Finish	MSL Peak Temp (3)	Op Temp (°C)	Top-Side Markings (4)	Samples
TPS65735RSNR	ACTIVE	QFN	RSN	32	3000	Green (RoHS & no Sb/Br)	CU NIPDAU	Level-2-260C-1 YEAR	-40 to 85	TPS 65735	Samples
TPS65735RSNT	PREVIEW	QFN	RSN	32	250	Green (RoHS & no Sb/Br)	CU NIPDAU	Level-2-260C-1 YEAR	-40 to 85	TPS 65735	

(1) The marketing status values are defined as follows:

ACTIVE: Product device recommended for new designs.

LIFEBUY: TI has announced that the device will be discontinued, and a lifetime-buy period is in effect.

NRND: Not recommended for new designs. Device is in production to support existing customers, but TI does not recommend using this part in a new design.

PREVIEW: Device has been announced but is not in production. Samples may or may not be available.

OBSOLETE: TI has discontinued the production of the device.

(2) Eco Plan - The planned eco-friendly classification: Pb-Free (RoHS), Pb-Free (RoHS Exempt), or Green (RoHS & no Sb/Br) - please check <http://www.ti.com/productcontent> for the latest availability information and additional product content details.

TBD: The Pb-Free/Green conversion plan has not been defined.

Pb-Free (RoHS): TI's terms "Lead-Free" or "Pb-Free" mean semiconductor products that are compatible with the current RoHS requirements for all 6 substances, including the requirement that lead not exceed 0.1% by weight in homogeneous materials. Where designed to be soldered at high temperatures, TI Pb-Free products are suitable for use in specified lead-free processes.

Pb-Free (RoHS Exempt): This component has a RoHS exemption for either 1) lead-based flip-chip solder bumps used between the die and package, or 2) lead-based die adhesive used between the die and leadframe. The component is otherwise considered Pb-Free (RoHS compatible) as defined above.

Green (RoHS & no Sb/Br): TI defines "Green" to mean Pb-Free (RoHS compatible), and free of Bromine (Br) and Antimony (Sb) based flame retardants (Br or Sb do not exceed 0.1% by weight in homogeneous material)

(3) MSL, Peak Temp. -- The Moisture Sensitivity Level rating according to the JEDEC industry standard classifications, and peak solder temperature.

(4) Multiple Top-Side Markings will be inside parentheses. Only one Top-Side Marking contained in parentheses and separated by a "~" will appear on a device. If a line is indented then it is a continuation of the previous line and the two combined represent the entire Top-Side Marking for that device.

Important Information and Disclaimer: The information provided on this page represents TI's knowledge and belief as of the date that it is provided. TI bases its knowledge and belief on information provided by third parties, and makes no representation or warranty as to the accuracy of such information. Efforts are underway to better integrate information from third parties. TI has taken and continues to take reasonable steps to provide representative and accurate information but may not have conducted destructive testing or chemical analysis on incoming materials and chemicals. TI and TI suppliers consider certain information to be proprietary, and thus CAS numbers and other limited information may not be available for release.

In no event shall TI's liability arising out of such information exceed the total purchase price of the TI part(s) at issue in this document sold by TI to Customer on an annual basis.

TAPE AND REEL INFORMATION



QUADRANT ASSIGNMENTS FOR PIN 1 ORIENTATION IN TAPE



*All dimensions are nominal

Device	Package Type	Package Drawing	Pins	SPQ	Reel Diameter (mm)	Reel Width W1 (mm)	A0 (mm)	B0 (mm)	K0 (mm)	P1 (mm)	W (mm)	Pin1 Quadrant
TPS65735RSNT	QFN	RSN	32	250	180.0	12.4	4.25	4.25	1.15	8.0	12.0	Q2

TAPE AND REEL BOX DIMENSIONS

*All dimensions are nominal

Device	Package Type	Package Drawing	Pins	SPQ	Length (mm)	Width (mm)	Height (mm)
TPS65735RSNT	QFN	RSN	32	250	552.0	185.0	36.0

RSN (S-PWQFN-N32)

PLASTIC QUAD FLATPACK NO-LEAD

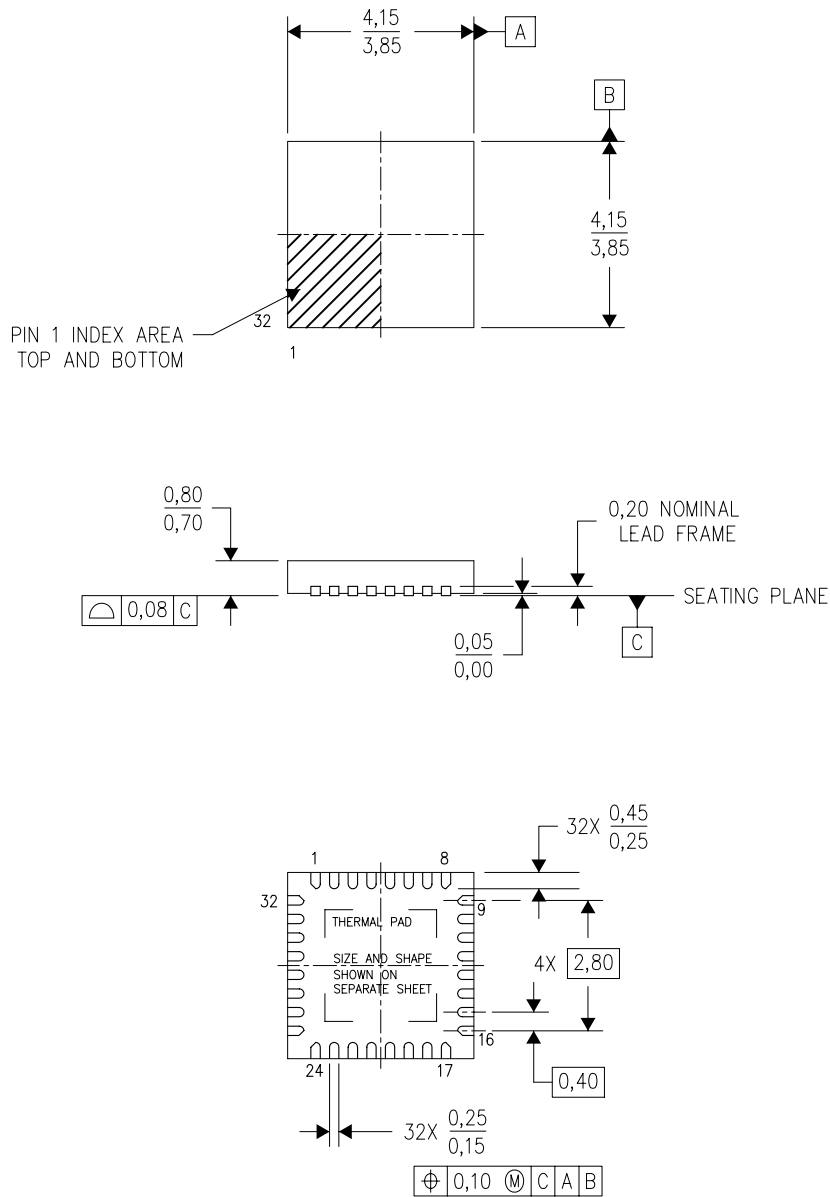

4207561/C 08/11

- NOTES:
- All linear dimensions are in millimeters. Dimensioning and tolerancing per ASME Y14.5M-1994.
 - This drawing is subject to change without notice.
 - QFN (Quad Flatpack No-Lead) Package configuration.
 - The package thermal pad must be soldered to the board for thermal and mechanical performance.
 - See the additional figure in the Product Data Sheet for details regarding the exposed thermal pad features and dimensions.

THERMAL PAD MECHANICAL DATA

RSN (S-PWQFN-N32)

PLASTIC QUAD FLATPACK NO-LEAD

THERMAL INFORMATION

This package incorporates an exposed thermal pad that is designed to be attached directly to an external heatsink. The thermal pad must be soldered directly to the printed circuit board (PCB). After soldering, the PCB can be used as a heatsink. In addition, through the use of thermal vias, the thermal pad can be attached directly to the appropriate copper plane shown in the electrical schematic for the device, or alternatively, can be attached to a special heatsink structure designed into the PCB. This design optimizes the heat transfer from the integrated circuit (IC).

For information on the Quad Flatpack No-Lead (QFN) package and its advantages, refer to Application Report, QFN/SON PCB Attachment, Texas Instruments Literature No. SLUA271. This document is available at www.ti.com.

The exposed thermal pad dimensions for this package are shown in the following illustration.

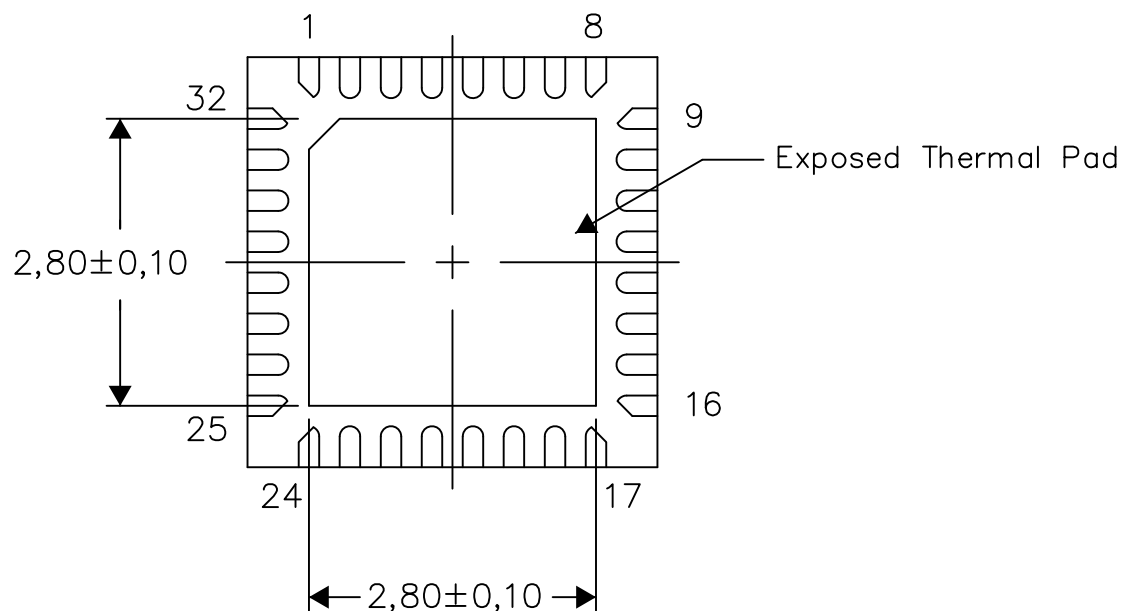

Bottom View

Exposed Thermal Pad Dimensions

4209775-2/F 03/14

NOTE: All linear dimensions are in millimeters

RSN (S-PWQFN-N32)

PLASTIC QUAD FLATPACK NO-LEAD

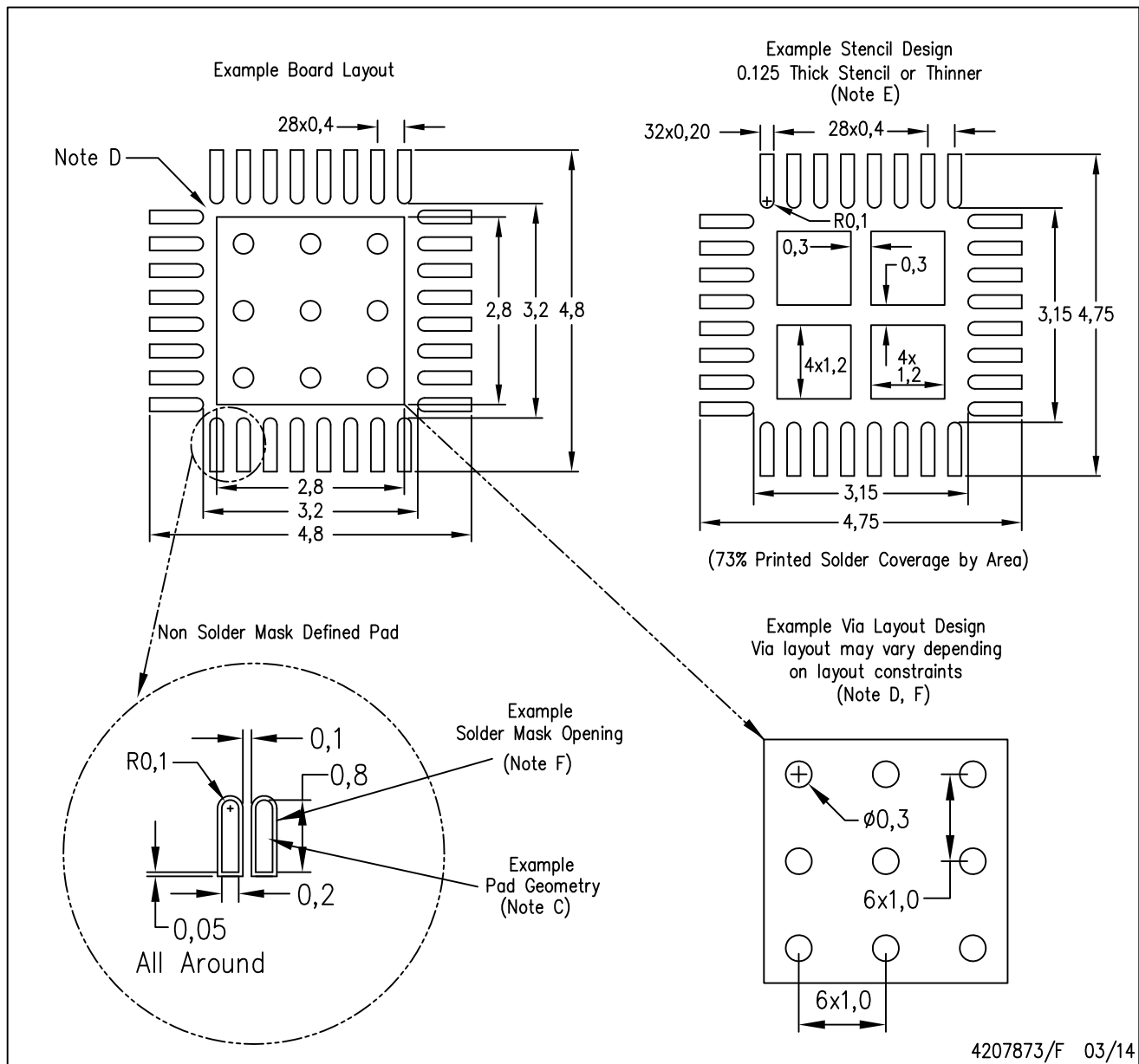

- NOTES:
- All linear dimensions are in millimeters.
 - This drawing is subject to change without notice.
 - Publication IPC-7351 is recommended for alternate designs.
 - This package is designed to be soldered to a thermal pad on the board. Refer to Application Note, Quad Flat-Pack Packages, Texas Instruments Literature No. SLUA271, and also the Product Data Sheets for specific thermal information, via requirements, and recommended board layout. These documents are available at www.ti.com <<http://www.ti.com>>.
 - Laser cutting apertures with trapezoidal walls and also rounding corners will offer better paste release. Customers should contact their board assembly site for stencil design recommendations. Refer to IPC 7525 for stencil design considerations.
 - Customers should contact their board fabrication site for recommended solder mask tolerances and via tenting recommendations for vias placed in the thermal pad.

IMPORTANT NOTICE

Texas Instruments Incorporated and its subsidiaries (TI) reserve the right to make corrections, enhancements, improvements and other changes to its semiconductor products and services per JESD46, latest issue, and to discontinue any product or service per JESD48, latest issue. Buyers should obtain the latest relevant information before placing orders and should verify that such information is current and complete. All semiconductor products (also referred to herein as "components") are sold subject to TI's terms and conditions of sale supplied at the time of order acknowledgment.

TI warrants performance of its components to the specifications applicable at the time of sale, in accordance with the warranty in TI's terms and conditions of sale of semiconductor products. Testing and other quality control techniques are used to the extent TI deems necessary to support this warranty. Except where mandated by applicable law, testing of all parameters of each component is not necessarily performed.

TI assumes no liability for applications assistance or the design of Buyers' products. Buyers are responsible for their products and applications using TI components. To minimize the risks associated with Buyers' products and applications, Buyers should provide adequate design and operating safeguards.

TI does not warrant or represent that any license, either express or implied, is granted under any patent right, copyright, mask work right, or other intellectual property right relating to any combination, machine, or process in which TI components or services are used. Information published by TI regarding third-party products or services does not constitute a license to use such products or services or a warranty or endorsement thereof. Use of such information may require a license from a third party under the patents or other intellectual property of the third party, or a license from TI under the patents or other intellectual property of TI.

Reproduction of significant portions of TI information in TI data books or data sheets is permissible only if reproduction is without alteration and is accompanied by all associated warranties, conditions, limitations, and notices. TI is not responsible or liable for such altered documentation. Information of third parties may be subject to additional restrictions.

Resale of TI components or services with statements different from or beyond the parameters stated by TI for that component or service voids all express and any implied warranties for the associated TI component or service and is an unfair and deceptive business practice. TI is not responsible or liable for any such statements.

Buyer acknowledges and agrees that it is solely responsible for compliance with all legal, regulatory and safety-related requirements concerning its products, and any use of TI components in its applications, notwithstanding any applications-related information or support that may be provided by TI. Buyer represents and agrees that it has all the necessary expertise to create and implement safeguards which anticipate dangerous consequences of failures, monitor failures and their consequences, lessen the likelihood of failures that might cause harm and take appropriate remedial actions. Buyer will fully indemnify TI and its representatives against any damages arising out of the use of any TI components in safety-critical applications.

In some cases, TI components may be promoted specifically to facilitate safety-related applications. With such components, TI's goal is to help enable customers to design and create their own end-product solutions that meet applicable functional safety standards and requirements. Nonetheless, such components are subject to these terms.

No TI components are authorized for use in FDA Class III (or similar life-critical medical equipment) unless authorized officers of the parties have executed a special agreement specifically governing such use.

Only those TI components which TI has specifically designated as military grade or "enhanced plastic" are designed and intended for use in military/aerospace applications or environments. Buyer acknowledges and agrees that any military or aerospace use of TI components which have **not** been so designated is solely at the Buyer's risk, and that Buyer is solely responsible for compliance with all legal and regulatory requirements in connection with such use.

TI has specifically designated certain components as meeting ISO/TS16949 requirements, mainly for automotive use. In any case of use of non-designated products, TI will not be responsible for any failure to meet ISO/TS16949.

Products

Audio	www.ti.com/audio
Amplifiers	amplifier.ti.com
Data Converters	dataconverter.ti.com
DLP® Products	www.dlp.com
DSP	dsp.ti.com
Clocks and Timers	www.ti.com/clocks
Interface	interface.ti.com
Logic	logic.ti.com
Power Mgmt	power.ti.com
Microcontrollers	microcontroller.ti.com
RFID	www.ti-rfid.com
OMAP Applications Processors	www.ti.com/omap
Wireless Connectivity	www.ti.com/wirelessconnectivity

Applications

Automotive and Transportation	www.ti.com/automotive
Communications and Telecom	www.ti.com/communications
Computers and Peripherals	www.ti.com/computers
Consumer Electronics	www.ti.com/consumer-apps
Energy and Lighting	www.ti.com/energy
Industrial	www.ti.com/industrial
Medical	www.ti.com/medical
Security	www.ti.com/security
Space, Avionics and Defense	www.ti.com/space-avionics-defense
Video and Imaging	www.ti.com/video

TI E2E Community

e2e.ti.com